

**DESIGN OF ENGINE OPERATED ROCKER SPRAYER WITH
KAMCO REPAER ENGINE AS THE PRIME MOWER**

BY

**ANUSREE ARAVIND (2016-02-011)
JYOTHISH CHANDRAN (2016-02-021)
VISHNU GOPAL A (2016-02-047)**



**DEPARTMENT OF FARM MACHINERY POWER
ENGINEERING
KELAPPAJI COLLEGE OF AGRICULTURAL
ENGINEERING AND
TECHNOLOGY
TAVANUR - 679 573, MALAPPURAM
KERALA, INDIA
2020**

**DESIGN OF ENGINE OPERATED ROCKER SPRAYER WITH KAMCO
REPAER ENGINE AS THE PRIME MOWER**

BY
ANUSREE ARAVIND (2016-02-011)
JYOTHISH CHANDRAN (2016-02-021)
VISHNU GOPAL A (2016-02-047)

THESIS
Submitted in partial fulfilment of the requirement for the degree of

BACHELOR OF TECHNOLOGY

IN

AGRICULTURAL ENGINEERING

(FARM MACHINERY POWER ENGINEERING)

Faculty of Agricultural Engineering and Technology

KERALA AGRICULTURAL UNIVERSITY



DEPARTMENT OF FARM MACHINERY POWER ENGINEERING
KELAPPAJI COLLEGE OF AGRICULTURAL ENGINEERING AND
TECHNOLOGY

TAVANUR - 679 573, MALAPPURAM

KERALA, INDIA

2020

DECLARATION

We hereby declare that this thesis entitled “Design of engine operated rocker sprayer with KAMCO reaper engine as the prime mower” is a bonafide record of research work done by us during the course of research and the thesis has not previously formed the basis for the award of any degree, diploma, associateship, fellowship or other similar title of any other University or Society.

Place: Tavanur

Date:

Anusree Aravind (2016-02-011)

Jyothish Chandran (2016-02-021)

Vishnu Gopal A (2016-02-047)

CERTIFICATE

Certified that this thesis entitled “Design of engine operated rocker sprayer with KAMCO reaper engine as the prime mower” is a bonafide record of research work done independently by Anusree Aravind (2016-02-011), Jyothish Chandran (2016-02-021) and Vishnu Gopal A (2016-02-047) under my guidance and supervision and that it has not previously formed the basis for the award of any degree, diploma, fellowship or associate ship to him.

Place: Tavanur

Date:

Er. Sindhu Bhasker,

Assitainat professor,

Dept.FMPE

Kellapaji college of Agricultural

Engineering and Technology

Tavanur, Malappuram-679573

ACKNOWLEDGEMENT

First of all, we would like to thank God Almighty for His grace for giving courage, resources and blessing to complete this endeavour. He is the source of everything without whose grace nothing is possible.

We would like to express our devout gratitude towards Er. Sindhu Bhasker Assistant Professor, FMPE KCAET, Tavanur for her proper guidance, instilling motivation and valuable advices which have driven the pace of completion of the work within stipulated time.

We are greatly indebted to Dr. Sathian K.K., Dean in charge for his support and encouragement for granting us the necessary permissions and helping us complete the project.

We would like to express our deep sense of gratitude to Er. Avish, and Er. Sanju Sukumaran, Assistant Professors of the Dept. of FMPE, KCAET for their immense support and valuable advices during the course of the work.

We thank all the staff under the AICRP on FIM especially Sri. Likesh M., Sri. Shobith P. V., Sri Shajith Bhaskar for their ever-willing help and coordination.

Words are not enough to express the deep sense of gratitude and love for family members and friends for all the moral support and encouragement which instilled the motivation and confidence for the completion of project.

Finally, we thank all of those, who directly or indirectly helped us.

*Anusree Aravind
Jyothish Chandran
Vishnu Gopal A*

CONTENT

CHAPTER NO.	TITLE	PAGE NO.
	LIST OF FIGURES	ii
	LIST OF PLATES	iii
	SYMBOL AND ABBREVIATION	iv
I	INTRODUCTION	1
II	REVIEW OF LITERATURE	4
III	METERIALS AND METHODS	13
IV	RESULTS AND DISCUSSION	26
V	SUMMERY AND CONCLUSION	30
	REFERENCES	32
	ABSTRACT	34

TABLE OF FIGURES

FIGURE NO	TITLE	PAGE NO
2.1	FORCES ACTING ON A SLIDER CRANK	7
2.2	FORCES ACTING ON SLIDER CRANK	9
2.3	INERTIA FORCE ACTING ON SLIDER CRANK	9
3.1	PLAN OF ENGINE OPERATED ROCKER SPRAYER	17
3.2	FRONT VIEW OF THE ENGINE OPERATED ROCKER SPRAYER	17
3.3	SLIDER CRANK MECHANISM	18
3.4	DESIGNING SLIDER CRANK MECHANISM	19
3.5	CONNECTING SHAFT	20
3.6	DIFFERENT VIEWS OF CONNECTING SHAFT	21
3.7	GEAR MECHANISM	24
3.8	SOCKET AND CONNECTING ROD	25

TABLE OF PLATES

PLATE NO	TITLE	PAGE NO
3.1	REAPER FRAME	
	a)A VIEW FROM FRONT	13
	b)A VIEW FROM SIDE	13
3.2	ROCKER SPRAYER	15
3.3	REDUCTION GEAR BOX(INPUT SECTION)	22
3.4	REDUCTION GEAR BOX (OUTPUT SHAFT)	23
3.5	REDUCTION GEAR BOX(SIDE VIEW)	23

SYMBOL AND ABBREVIATION

Abbreviations/Notation	Description
%	Percentage
°	Degree
cm	Centimetre (s)
et. al	And others
Fig.	Figure
g	Gram (s)
hp	Horse power
h	hour
KAU	Kerala Agricultural University
KCAET	Kelappaji College of Agricultural Engineering and Technology
kg	Kilogram
kg cm ²	Kilogram per square centimetre
rpm	Revolutions per minute
KPa	kilo Pascal
µm	Micro meters
m	Meter(s)
min	Minute(s)
mm	Millimetre(s)
<i>i. e</i>	That is
ha	hectare

CHAPTER I

INTRODUCTION

A reaper is a farm implement that reaps (cuts and often also gathers) crops at harvest when they are ripe. Usually the crop involved is a cereal grass. Most modern mechanical reapers cut the grass, most also gather it, either by windrowing it or picking it up. Mechanical reapers substantially changed agriculture from their appearance in the 1830s until the 1860s through 1880s, when they evolved into related machines, often called by different names, that collected and bound the sheaves of grain with wire or twine. Today reapers and grain binders have been largely replaced by combines in commercial farming, but some smaller farms still use them. Benefits of power reaper include

- Simple to use controls: Manual handling machine does not require separate machines for mounting.
- Cost effective and saves time.
- Light weighted machine so that it is easy to handle
- Suitable for various crops like bengal gram, black gram, green gram, wheat, soybean mustard and paddy etc.

KAMCO power reapers are one of the most popular reapers in Kerala and is ideally suited for harvesting of paddy, wheat and similar crops. It harvests and makes windrows at the rate of 3-4 hours per ha. Since fuel used is kerosene, cost of operation is the lowest. It cost around Rs.155000 per number. But even though, in the entire season the usage of reapers is only at the time of harvesting. This can lead to high maintenance which result in more maintenance cost. This also destroys the machines due to long time no use and rusting of parts. So in turn, it is not used effectively comparing its price. Hence at off season reaper can be utilised in some other way without altering its structure.

Some of the major thrust for improving agriculture productivity is by improving genetic resources, application of fertilizers and chemicals, improving

irrigation potential. Taking application of fertilisers and chemicals in to the aspects, insects, pests and weeds causes considerable damage to commercial crops. If not controlled in time, the entire crop gets lost and, therefore, farmers are likely to suffer in many ways. In a properly organised system, crop protection, therefore, is one of the most important means of increasing crop productivity. The chemical methods of plant production have been universally accepted due to saving of time, labour and its effectiveness with relatively low expenditure. A large number of herbicides and insecticides are now available in the market for control of a wide varieties of weeds and insects. The chemicals for protecting the plants from various injurious organisms need to be applied on plant surfaces in the form of sprays, dusts, mist, etc. Many different kinds of spraying and dusting machines are available to meet the requirement of agriculturist in controlling insects, diseases and weeds.

A sprayer is a device used to spray a liquid, where sprayers are commonly used for projection of water, weed killers, crop performance materials, pest maintenance chemicals, as well as manufacturing and production line ingredients. In agriculture, a sprayer is a piece of equipment that is used to apply herbicides, pesticides, and fertilizers on agricultural crops. Sprayers range in size from man-portable units to trailed sprayers that are connected to a tractor, to self-propelled units similar to tractors, with boom mounts of 4-30 feet up to 60–151 feet in length depending on engineering design for tractor and land size. There are a number of agriculture sprayers designed for spraying applications and designed to be versatile and suitable for various uses from spot applications, gardens, crops, row crops, crop trees, fruit, groves, vineyards, perimeter maintenance, livestock needs, weed control, pastures and rangeland. Examples include boom sprayers, knapsack sprayers, Compression sprayers, Rocker Sprayer, bucket type sprayer, hand atomizer, engine powered sprayers, air plane sprayers etc.

A rocker sprayer has a pump assembly, fixed on a wooden platform with an operating lever, a valve assembly with two ball valves, a pressure chamber, suction hose with strainer, and delivery hose with spray lance. When the plunger is pulled behind by pulling the lever away from the pump, the spray fluid from the container

is sucked through the strainer and pushes the bottom ball valve above and enters the pump. The movement of the lower ball valve is arrested by the upper valve seat. When the lever is pushed towards the pump, the sucked fluid is forced to enter the pressure chamber by opening the upper ball valve. The operation is continued till the entire suction pipe, ball valve assembly, delivery hose and a portion of pressure vessel is fitted with spray fluid and the pump operator finds it difficult to push the piston forward, due to the downward pressure developed by the entrapped compressed air in the pressure vessel. Thereafter, the trigger cut off valve will be opened to allow the spray fluid to rush through the nozzle and get atomized. Usually 14 to 18 kg/cm² pressure can be built in the pressure chamber and hence can be conveniently used for free spraying in orchards, horticulture crops, rubber vineyards and field crops.

Mechanising these sprayers by reducing manual efforts further and provide an external power supply would actually be resulting in developing high pressure and high discharge for covering large area. Tall trees up to a height of 20 feet can be sprayed with a power sprayer. It would be cost effective, less laborious and most importantly much easier operation. So combining the rocker sprayer with KAMCO power reaper can be a solution to resolve the problems discussed.

Keeping in view the above factors the project work “Design of engine operated rocker sprayer with KAMCO reaper engine as the prime mover” has been carried out with the following objectives

1. Study of KAMCO reaper engine as the power source to the rocker sprayer
2. Study of rocker sprayer
3. Modification of gear box for rocker sprayer
4. Design of engine operated rocker sprayer with KAMCO reaper engine as the prime mover.

CHAPTER II

REVIEW OF LITERATURE

This chapter contains the reviews that helped in the designing criteria of the project. The researches on rocker sprayers, the mechanisms involving in various movement and conditions for the proper working of rocker sprayers were some important helping aid for this project and hence this section is explained with following titles.

1. Modifications on sprayers
2. Slider-Crank mechanism
3. Rocker sprayer

2.1 Modification on sprayers

Sivanainthapermal *et al.* (2018) designed and developed a wheel spray pump, a mobile pesticide sprayer and his design help the workers with reducing back ache and shoulder pains while using the product. The product can spray pesticide over multiple rows of plants in one pass there by reduces manual effort. The different design concepts were analysed with viewers and feedback was obtained where the final concept of design was selected.

Saptashish Deb *et al.* (2017) modified and tested a manually operated rocker sprayer to a power operated sprayer. Hand lever of existing sprayer was replaced with an electric motor. Speed of the motor was regulated by a voltage regulator. Power requirement of the sprayer was determined as 0.016 hp but due to market unavailability 0.25 hp motor was used. It was found that piston displacement and linear velocity increases with a decrease in the length of the connecting rod and vice versa.

To overcome the difficulties of the workers with the existing models, and to reduce the drudgery and musculoskeletal disorder problem that occurs because of the manual operation of the rocker sprayer, a modified model was developed for

the effective operation by using motor with a speed controlling device. In this modified model, the hand operated handle is replaced with a motor attached with eccentric disc through which connecting rod of piston is connected to provide reciprocating motion with the speed in the range of 70-110 rpm.

Samili S Deshmukh *et al.* (2018) designed and fabricated a three-wheel spray pump and the suggested model has removed the problem of back pain, since there is no need to carry the tank on the back. It has more number of nozzles which will cover maximum area of spraying in minimum time and at maximum rate. Muscular problems are removed and there is no need to operate the lever. It can be used for multiple crop.

When the equipment is push forward by using handles, front wheel rotates and the gear mounted at the axle of wheel also rotates and its rotation is then transferred to the pinion through the chain drive. The rotatory motion of the pinion is converted into the reciprocating motion by the single slider crank mechanism. Due to this arrangement, the connecting rod moves upward and downward which then reciprocate the piston of single acting reciprocating pump mounted at the top of storage tank. During the upward motion of the connecting rod, the pesticide is drawn into the pump and during the downward motion of connecting rod, the pesticide is forced to the delivery valve. The delivery valve is connected to the pipe carrying the number of nozzles. Due to the motion of wheels, the chain drive mechanism operates to reciprocate the piston inside the pump cylinder. But, this results in building up of pressure which seizes the movement of wheels. Thus, a clutch mechanism is provided to disengage the transmission from the crank to the piston.

Babasaheb Gholap and Ravi Mathur (2013) in their research paper on field evaluation of tractor operated boom sprayer of cotton crop calculated the uniformity coefficient, droplet size, droplet density. India is second largest producer of cotton in the world though the yield is only 440 kg/ha as against the world average of 667 kg/ha, due to poor control of insect pest and dry land farming conditions. During

pesticide application most of the pesticide is lost through drift. A major reason for such a pesticide loss is insufficient nozzle pressure, nozzle discharge, nozzle height etc. Hence, it is necessary to determine the optimum discharge rate and pressure so as to reduce the pesticide losses from the sprayer. Therefore, the hydraulic boom sprayer was tested in the field for cotton crop to study effect of nozzle discharge rates (viz., 0.45, 0.70, 0.90 and 1.35 l/min) and nozzle pressures (viz., 275.8, 413.7, 551.6 and 689.5 KPa) for spray uniformity. From the study it was found that nozzle discharge rate of 0.90 l/min and nozzle pressure of 689.5 KPa produced more uniform spray with droplet size of 125.55 to 287.50 μm , droplet density of 18 to 30 drops/ cm^2 and uniformity coefficient of 0.96 to 1.20.

The VMD of boom sprayer varied from 125.55 μm to 287.50 μm at nozzle discharge rates of 0.45, 0.70, 0.90 and 1.35 l/min and nozzle pressure of 275.8, 413.7, 551.6 and 689.5 KPa. The smallest droplet size was at the nozzle pressure of 689.5 KPa and nozzle discharge of 0.90 l/min and the largest size was at a nozzle pressure of 275.8 KPa and discharge rate of 0.45 l/min. The droplet sizes (VMD) were very close to the effective range of 150 μm to 250 μm (Mathews, 1979). The droplet size for top upper and top lower plant position were found as 181.55 μm and 174.47 μm , bottom upper and bottom lower were found as 172.80 and 169.71, whereas for bottom upper and bottom lower these were 165.68 μm and 155.44 μm . The droplet size for three different locations. Optimum droplet size was obtained for nozzle discharge rate of 0.90 l/min and nozzle pressure of 689.5 KPa.

The uniformity coefficient of sprayer was found in the range 0.96 to 1.20. The uniformity coefficient for top upper and top lower plant position were 1.23 and 1.23, middle upper and middle lower were 1.20 and 1.13, whereas for bottom upper and bottom lower plant position these were 1.12 and 0.99. The uniformity coefficient of boom sprayer for 0.90 l/min nozzle discharge and 689.5 KPa operating pressure.

The droplet density of boom sprayer varied from 18- 30 drops/ cm^2 . The droplet densities for top upper and top lower position were 29 and 23 drops/ cm^2 ,

middle upper and middle lower position were 20 and 19 drops/cm², whereas for bottom upper and bottom lower plant position these were 19 and 17 drops/cm². The droplet density for various plant positions.

2.2 Slider-crank mechanism

A slider-crank linkage is a four-link mechanism with three revolute joints and one prismatic or sliding or joint. The rotation of the crank drives the slider, or the expansion of gases against a sliding piston in a cylinder can drive the rotation of the crank. There are two types of slider-cranks: in-line and offset.

In-line: An in-line slider-crank has its slider positioned, so the line of travel of the hinged joint of the slider passes through the base joint of the crank. This creates a symmetric slider movement back and forth as the crank rotates.

Offset: If the line of travel of the hinged joint of the slider does not pass through the base pivot of the crank, the slider movement is not symmetric. It moves faster in one direction than the other. This is called a quick-return mechanism.

2.2.1 Forces acting on slider crank mechanism

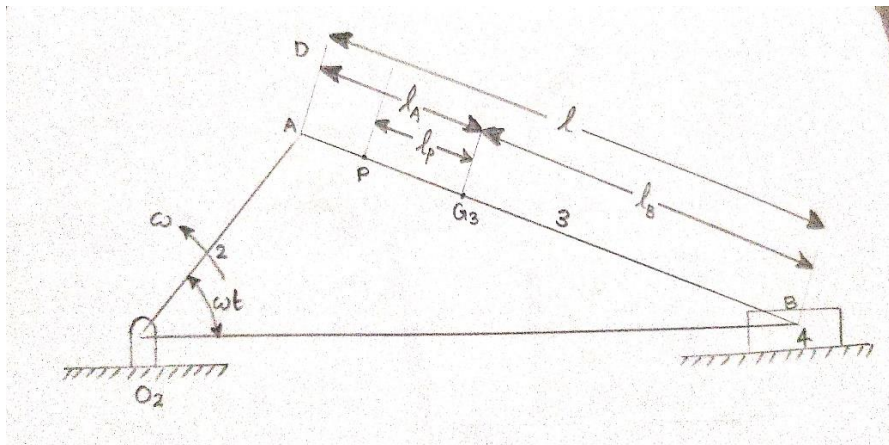

Fig 2.1 Forces acting on slider crank

For force analysis the mass of the connecting rod, m_3 is assumed to be concentrated at its centre of mass, G_3 . This mass is divided into two parts: m_{3B} concentrated at the wrist pin, B and m_{3P} concentrated at the centre of percussion, P for oscillation

of the rod about B. This disposition of the mass of the connecting rod is dynamically equivalent to the original rod if

- the total mass is the same
- the position of the centre of mass, G_3 is unchanged
- the moment of inertia is the same.

In other words, $m_3 = m_{3B} + m_{3P}$

$$m_{3B} l_B = m_{3P} l_P$$

and $I_G = m_{3B} l_B^2 + m_{3P} l_P^2$.

Therefore, $m_{3B} = m_3 [l_P / (l_B + l_P)]$ and $m_{3P} = m_3 [l_B / (l_B + l_P)]$ and

$$I_G = m_3 [l_P / (l_B + l_P)] l_B^2 + m_3 [l_B / (l_B + l_P)] l_P^2 = m_3 l_P l_B.$$

Or $l_P l_B = I_G / m_3$.

In the usual connecting rod, the centre of percussion is close to the crank pin and it is assumed that they are coincident. In that case, $l_A = l_P$ and the two mass concentrations become:

$$m_{3B} = m_3 l_A / l \text{ and } m_{3P} = m_3 l_B / l.$$

These equivalent masses are not exact, but close enough for usual connecting rods. These result in a moment of inertia, $I'_G = m_3 l_A l_B$, which is greater than I_G . This means the inertia torque of such an equivalent system is higher than the actual value. This can be corrected by introducing a correction couple opposite in sense to the inertia couple.

$$\text{Correction couple, } \Delta T = (I'_G - I_G) \alpha_3 = m_3 l_B \alpha_3 (l_A - l_P).$$

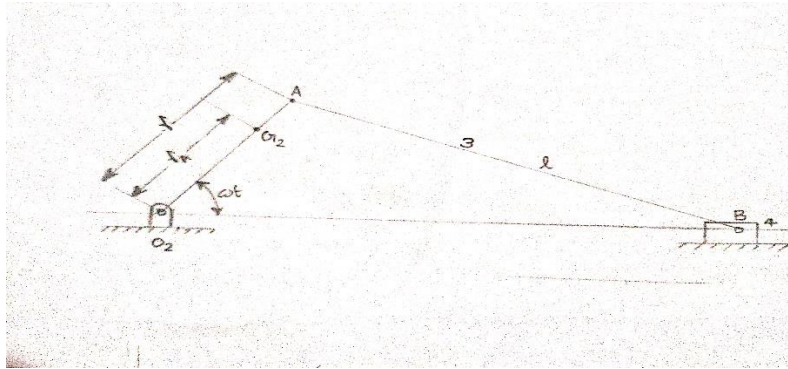

Fig 2.2 Forces acting on slider crank

Figure above shows an engine linkage where the mass of the crank is not balanced. The crank mass, m_2 can be considered to be concentrated at G_2 , the centre of mass of the crank, located at a distance r_G from the axis of rotation through O_2 . In the inertia force analysis, this mass m_2 is distributed at the crankpin with its value being m_{2A} and at the crankshaft with value m_{2O_2} .

For equivalence, $m_2 r_G = m_{2A} r + m_{2O_2} 0$.

Or, $m_{2A} = m_2 r_G / r$.

If the crank is fully balanced, point G_2 coincides with O_2 and hence its acceleration is zero, or there is no inertia force due to its mass.

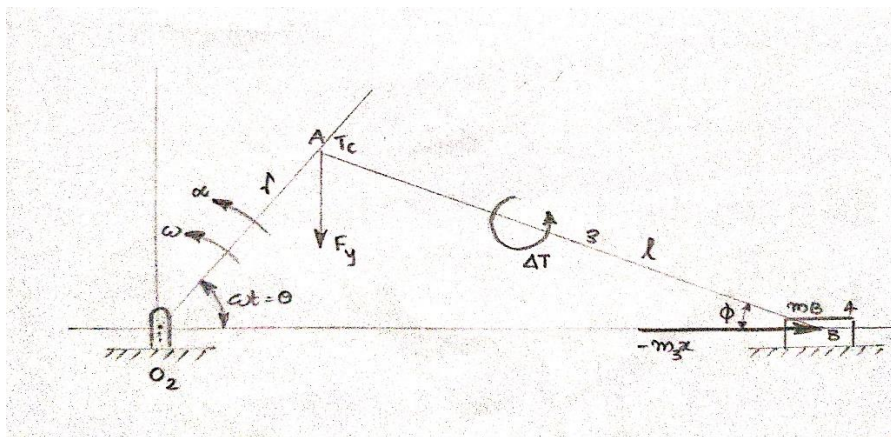

Fig 2.3 inertia force acting on slider crank

The acceleration of the piston is given by

$x'' = r \alpha [\sin \theta + (r/2l) \sin 2\theta] + r \omega^2 [\cos \theta + (r/l) \cos 2\theta]$. For constant angular velocity, angular acceleration, $\alpha = 0$. Therefore, $x'' = r \omega^2 [\cos \theta + (r/l) \cos 2\theta]$.

To simplify inertia force analysis, the masses of the links are located at the crank pin and the wrist pin by their equivalent masses. Thus, crank pin mass $m_A = m_{2A} + m_{3B}$, and

Wrist pin mass $m_B = m_{3B} + m_4$.

The inertia force at B due to the reciprocating mass, $F_{iB} = -m_B x'' = -m_B r \omega^2 [\cos \theta + (r/l) \cos 2\theta]$. The torque on the crank shaft due to this inertia force,

$$T_{iB} = -m_B r^2 \omega^2 [\cos \theta + (r/l) \cos 2\theta] \left\{ \sin \theta + \frac{\sin 2\theta}{2} \sqrt{\left[\frac{l^2}{r^2} - \sin^2 \theta \right]} \right\}.$$

Because of the assumption that the second equivalent mass is located at A instead of at the centre of percussion of the connecting rod, P, the correction couple is $\Delta T = m_{3B} \alpha^3 (l_A - l_P)$. If F_y is the vertical force at A making the correction couple on the connecting rod, $F_y = \Delta T / (l \cos \phi)$. Therefore, the correction torque on the crank shaft, $T_c = F_y r \cos \theta = [\Delta T / (l \cos \phi)] r \cos \theta$

$$= \left[\frac{\Delta T}{l/r} \right] \left\{ \cos \theta \sqrt{1 - \left[\frac{r}{l} \sin \theta \right]^2} \right\}$$

$$T_c = \Delta T \cos \theta / \sqrt{\left[\frac{l^2}{r^2} - \sin^2 \theta \right]}$$

Also due to the weight of the mass at the crank pin a torque is exerted on the crankshaft, which is given by

$$T_A = (m_A g) r \cos \theta.$$

In case of vertical engines, a torque is exerted on the crankshaft due to the weight of the mass at B, m_B , which is given by

$$T_B = (m_B g) r \left\{ \sin \theta + \frac{\sin 2\theta}{2} \sqrt{\left[\frac{l^2}{r^2} - \sin^2 \theta \right]} \right\}.$$

The angular acceleration of the connecting rod,

$$\alpha^3 = -\omega^2 \sin \theta \left\{ \left[\frac{l^2}{r^2} - 1 \right] / \left[\frac{l^2}{r^2} - \sin^2 \theta \right]^{3/2} \right\}.$$

2.3 Rocker sprayer

The rocker sprayer is a long lever high-pressure sprayer designed for operation with one or two lances. The complete assembly is mounted on a wooden board, which is held to the ground by the foot of the operator. The sprayer consists of a single or double acting piston pump for developing high pressure, an air chamber, spray lance with shut off valve and strainer, 5 m suction line fitted with strainer and delivery line. The principal components are made from brass alloy. The lance is fitted with gooseneck bend and nozzle and the length of lance may vary from 60 to 90 cm. The pump is operated with long lever, to and fro in a rocking motion which suck the liquid from the inlet pipe submerged in the spray liquid. The other person holds the lance and directs the spray chemical to the target. If two lances are used, then it may require in all three persons for the spraying operation. With high jet spray gun or bamboo lance the spray chemical can be delivered to a height of up to 10 m. Used for spraying on tall trees like coconut, areca nut, sugarcane, rubber plantations, orchards, vineyards and field crops, vegetable gardens, flower crops etc.

Saptashish Deb et al. (2017) found out through their experiment that the speed of the manually operated sprayer which was operated manually, was found to work with an average speed of 74 rpm of the piston movement

Pankaj B. Gavali and Shashidhar. S. review on pesticides sprayer technology approach in ergonomics, economics and ecologic in agriculture field specify that in current pesticide spraying technologies for specialty crops frequently result in over-application and excessive off-target losses and spray drift, primarily due to large variations in canopy sizes and densities, plant spacing, and constant pesticide delivery rate offered by conventional sprayers. Existing works by researches as given an idea about on the pesticides sprayers are related to Fluid injection metering, advancement in nozzle and electrostatic sprayers. The technology which permit sprayers to automatically match spray operating parameters to crop characteristics, insect/disease pressures and microclimatic

conditions during pesticide spray applications in field, a technology of an automatic variable-rate nozzle flow control unit comprised of a high speed laser scanning sensor along with an embedded computer and a touch screen to characterize crop presence, and shape. Therefore, the future work can be done on raking of Pesticide Sprayer based on ergonomic, economic, and efficacy and ecological evaluation.

CHAPTER III

MATERIALS AND METHODS

The project was carried out at the farm machinery lab of kelappaji college of agricultural engineering and technology tavanur, Malappuram. This Chapter details the methodology that were adopted in the project for the design and modification of rocker sprayer and to evaluate its performance in the field.

3.1 DEVELOPING THE FRAME

A proper framework is necessary for the stability and perfection of the work. The reaper frame was selected and cleaned to be the part that is going to supply the power to the sprayer.

3.1.1 Reaper engine

reaper engine with the rpm of 1800 was selected and cleaned, after evaluating the working parameters. The engine final rpm is calculated using tachometer.

Engine rpm = 1800 rpm

rpm obtained at the gear output = 460 rpm



a) A view from the front



b) A View from side

Plate 3.1 Reaper frame

3.1.2 Reaper specification

Model	120 M
Rated power in HP	3.75
rpm	1800
Fuel	petrol start, kerosene running
Engine make	greaves
Type	single cylinder 4 stroke CSD RR Side valve air cooled engine
Specific fuel consumption	440gm/Ps.hr
Travelling speed	forward 3.6 kmph Reverse 3.1 kmph
Crop release	right side of machine
Applicable plant height	60-120mm
Working capacity	1 hectare / 3-4 hr
Applicability	wet and dry field
Cutting device	reciprocating knife bar
Cutting height	5-20cm from ground level
Cutting width	120 cm

3.1.3 Rocker sprayer

- Type of piston = single acting
- Length of suction line = 2 m
- Air chamber capacity (l) = 2 l
- Total length of the supporting board = 30 cm
- Stroke length = 9 cm
- Length of delivery pipe = 2.5 m



Plate 3.2 Rocker Sprayer

3.1.4 Reduction of rpm

The rpm required for rocker sprayer operation is 74 rpm (average) (Saptashish Deb *et al.* 2017). To acquire this a gear setup is required.

$$\text{Gear ratio} = \frac{N_1}{N_2} = \frac{T_2}{T_1} \dots \dots \dots (3.1)$$

where,

- N₁ = speed of driven gear
- N₂=speed of driving gear
- T₁= number of teeth in driving gear
- T₂=number of teeth in driven gear

here,

$$N_1 = 74 \text{ rpm} \qquad N_2 = 460 \text{ rpm}$$

$$\text{gear ratio} = 0.16086 = T_2/T_1$$

Based on the gears available in market, gear with 20 teeth and 120 teeth is acceptable for this gear ratio. But considering the availability of space, a complex gear setup is adapted and finally the setup was landed on using a gear reduction box with a reduction ratio of 6:1.

But since the number of teeth is proportional to diametric pitch, the 120 tooth gear box will not be applicable with the small space on the frame.

3.2 DESIGNING OF COMPONENTS

The next step after getting the idea is to have a plan of the project. The modified view of rocker sprayer mainly consists of the reaper frame, rocker sprayer, connecting mechanism, the storage tank and the spraying nozzles.

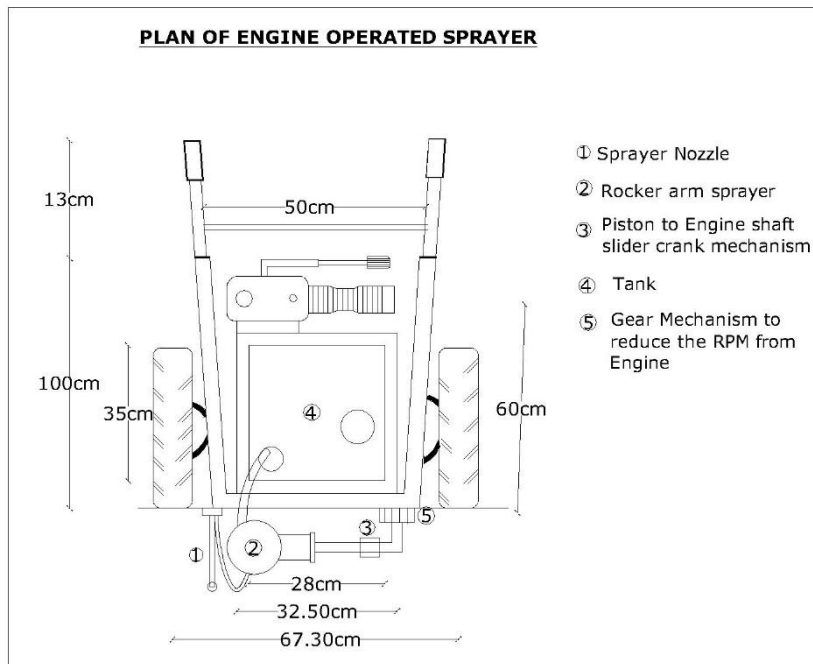

Fig 3.1 Plan of engine operated sprayer

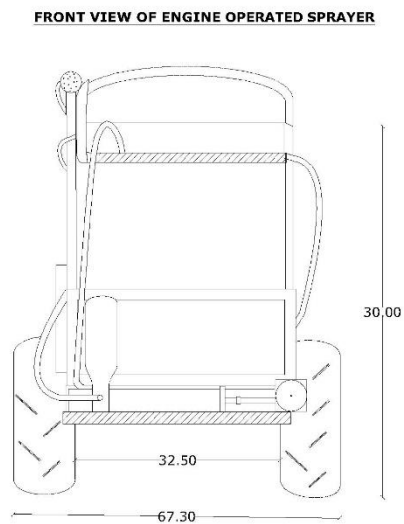

Fig 3.2 Front view of engine operated sprayer

Another most important part is designing the connecting mechanism required for the operation of the engine operated rocker sprayer

3.2.1 Slider-crank mechanism

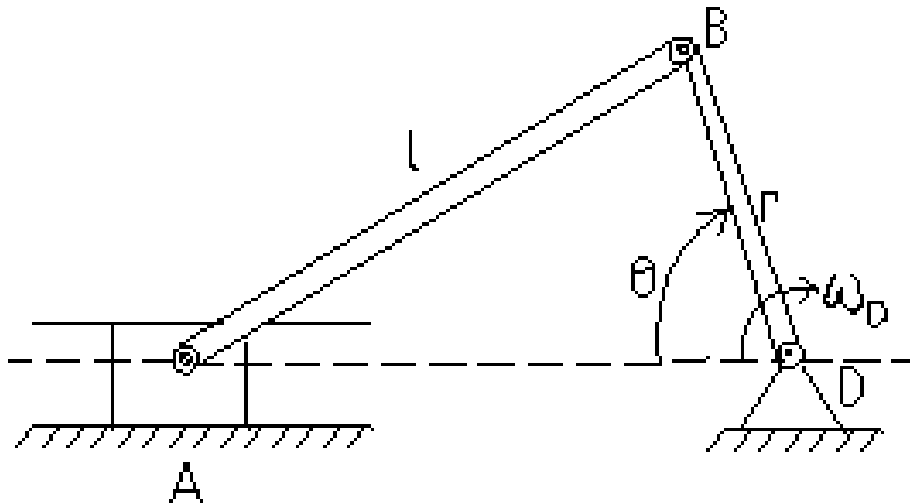

Fig 3.3 A Slider-crank mechanism

Here,

l = length of connecting rod to the sliding part which has both sliding and rotating motion

r = length of connecting rod to the rotating part

θ = the crank angle

ω_D = angular velocity of crank

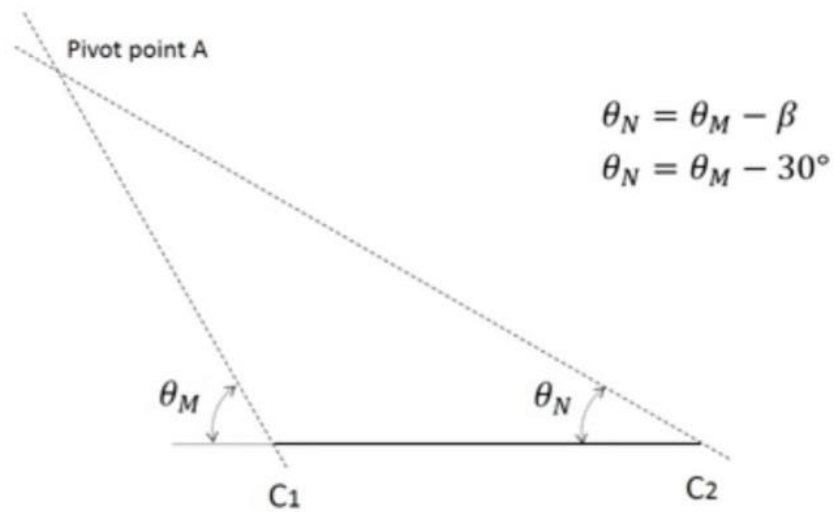

Fig 3.4 Designing Slider-Crank

Parameters required for designing:

- Time ratio (Q) = 1
- Imbalance angle $\beta = 180 \times \frac{Q-1}{Q+1}$
- Stroke length(C_1C_2) = 9cm
- $r = \frac{1}{2} (AC_2 - AC_1)$
- $l = AC_1 + r$

Since the time ratio here is 1, $\beta = 0$

$$\theta_M = \theta_N$$

So, there won't be a point A giving

$$r = \frac{1}{2} \text{ stroke length}$$

$$l = \text{stroke length} + r$$

therefore,

$$r = 4.5 \text{ cm}$$

$$l = 12.5 \text{ cm}$$

on standardising, $l = 13 \text{ cm}$

3.2.2 Connecting Shaft

For the proper transfer of power from engine to the reduction gear box, the connecting shaft is required. The shaft is designed and developed at the farm machinery workshop.

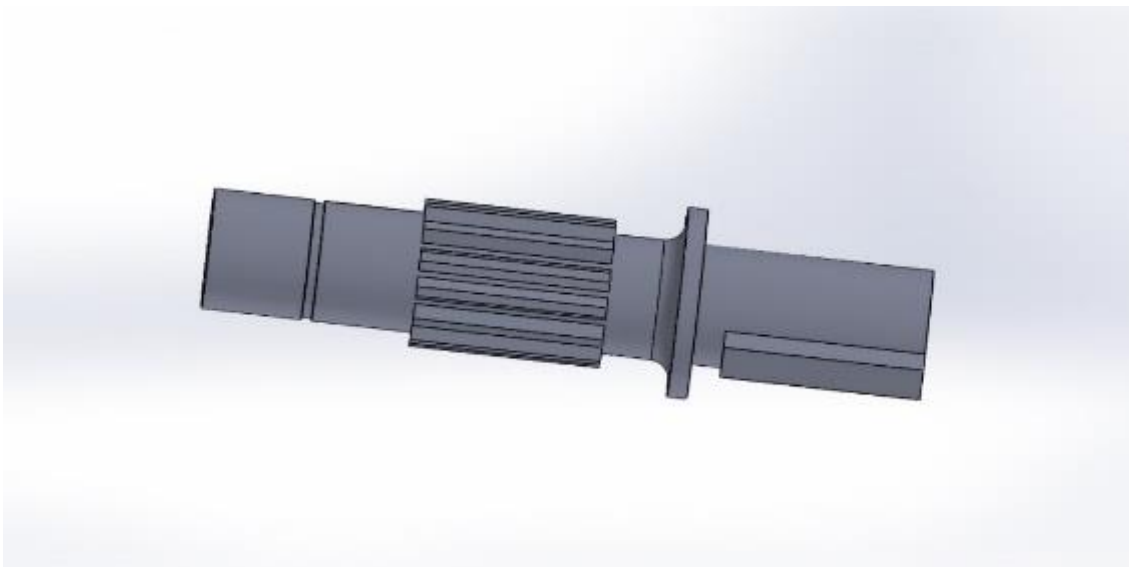

Fig 3.5 Connecting shaft

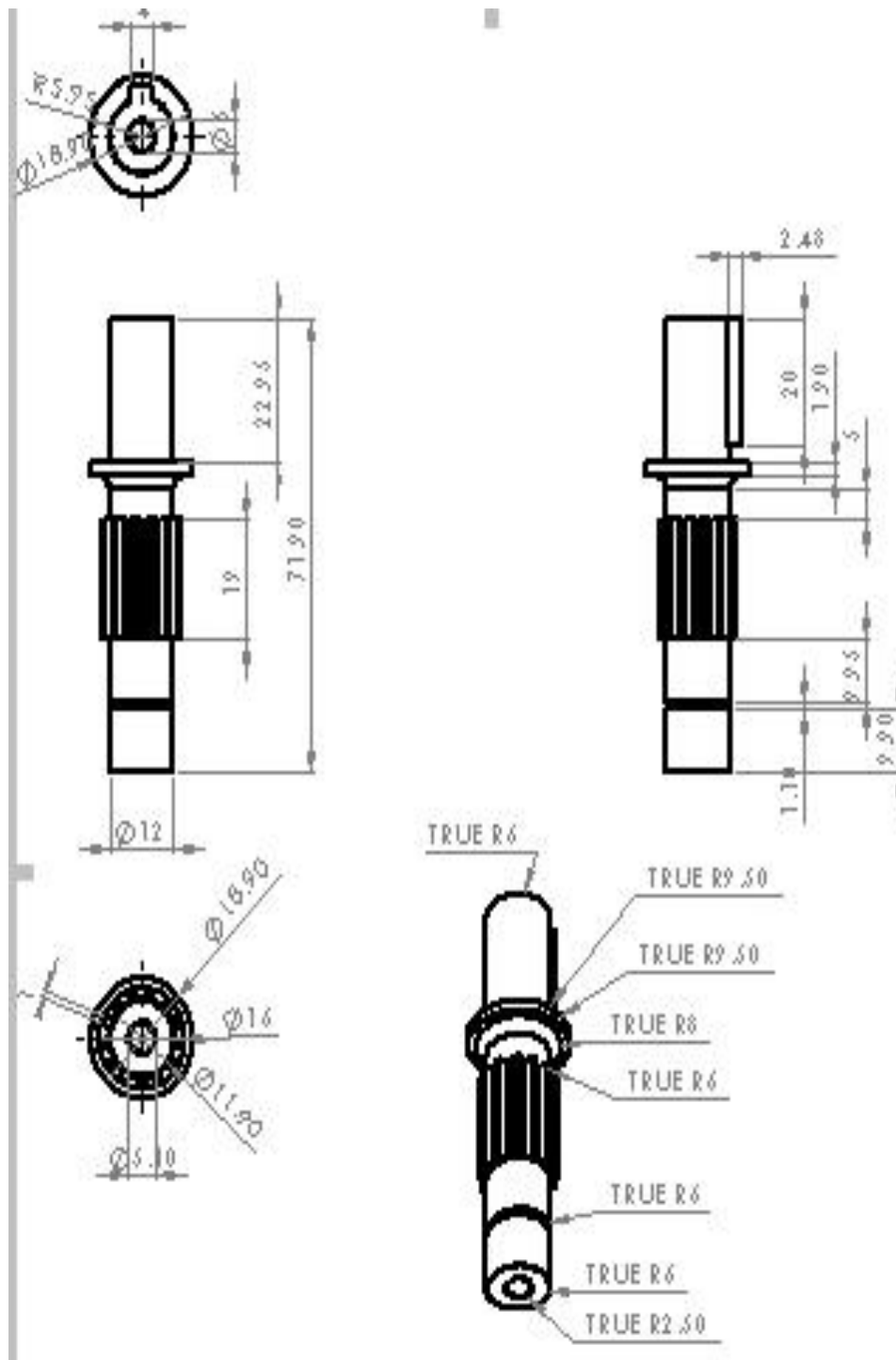

Fig 3.6 Different views of connecting shaft with dimensions

3.2.3 Modification of Gear Reduction Box

The rpm required for the operation of the rocker sprayer is found to be 74 rpm(average) (Saptashish Deb *et al.* 2017). But, the output rpm from reaper engine is 460 rpm. To reduce this into the required amount we use the reduction gear box.

Reduction gear box is used to reduce an input speed to a slower output speed and more output torque. The components are made with professional machines and tools in order to make their dimensions standardized to reach the replace ability. The gear boxes are sturdily constructed using superior quality metal, which resists the corrosion and tear & wear.



Plate 3.3 Reduction gear box (input section)



Plate 3.4 Reduction gear box (output shaft)



Plate 3.5 Reduction gear box (side view)

- The reduction ratio of the gear box required is $460/74 = 6/1 = 6:1$
- Since the market available gear box is of ratio 7.5:1 and application of this gear reduction box can lead to a pressure reduction, designing a gear box suitable for the engine operated model is required

Using the gear ratio equation (3.1), a gear setup of four gears are combined to get the required rpm. Four gears with the number of teeth 18,50,18,40 are selected and combined to form the reduction gear box setup.

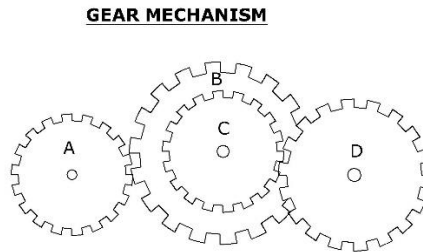

Fig. 3.7 gear mechanism

The rpm at gear A with 18 teeth = 460 rpm

This is meshed with another gear B with 50 teeth,

Hence, rpm of gear B,

Using gear ratio,

$$460/N_B = 50/18$$

Therefore,

$$N_B = 165.6 \text{ rpm}$$

This gear B is attached parallel to another gear C and hence, the rpm of gear B and gear C are equal, since they rotate on the same shaft.

rpm of gear C = 165.6 rpm

Gear C is meshed with another gear D with number of tooth 40

So, the rpm of gear D,

$$165.6/N_D = 40/18$$

rpm of gear D = 74.52 rpm

i. e. the required rpm for the rocker sprayer to operate.

Hence, a gear reduction box with these gears should be developed to acquire the required reduction in rpm.

3.2.4 Socket and connecting rod

After gaining the required rpm with the reduction gear box, the next process is to transmit this power to the rocker sprayer. The slider crank mechanism is used here. The two most important components in this mechanism are the two rod. One which has the rotating motion and the other which has both the rotating and sliding effect. For the rotating part of the mechanism a socket of 4.5 radius is designed and connected to the reduction gear box. The socket is followed by a rod of length 13 cm. The other end of the rod is connected to the piston of the rocker sprayer. Due to the small space constrain the length of the rod can be reduced but maximum up to 10 cm.

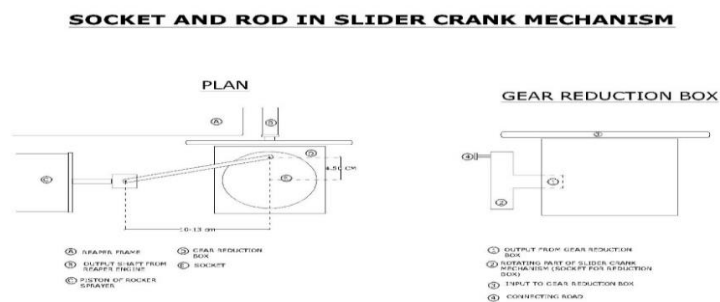

Fig 3.7 Socket and connecting rod

CHAPTER IV

RESULT AND DISCUSSION

A reaper is a farm implement that reaps (cuts and often also gathers) crops at harvest when they are ripe. Usually the crop involved is a cereal grass. Most modern mechanical reapers cut the grass, most also gather it, either by windrowing it or picking it up. Benefits of power reaper include they are simple to use controls i.e. Manual handling machine does not require separate machines for mounting. They are cost effective and saves time and are light weighted machine so that it is easy to handle. They are suitable for various crops like bengal gram, black gram, green gram, wheat, soybean mustard and paddy etc. But even though, In the entire season the usage of reapers is only at the time of harvesting. This can lead to high maintenance which result in more maintenance cost. This also destroys the machines due to long time no use and rusting of parts. So in turn, it is not used effectively comparing its price. Hence at off season reaper can be utilised in some other way without altering its structure.

Crop yield is reduced by mainly due to attack of pests, diseases and weed. Chemical control is the popular method adopted for controlling most insects, weed and diseases. The chemicals are applied either by spraying, sprinkling on the crop with help of pumper dusting. Spraying is one of the most effective and efficient techniques for applying small volume of spray liquid to protect crops.

In conventional methods, manually operated low and high volume sprayers and power operated sprayers are used to carry fluid at different targets. In this method, the time and labour required is more. It is difficult to spray the pesticide uniformly and effectively throughout the tree by conventional method of spraying. Though this method gives good pest control, it consumes large volume of liquid per plant, great amount of time and labour are required. Also drip losses are more.

Owing to concern towards protecting environment from pollution by excessive use of pesticide and to economies the spraying method suitable

alternative should be identified. In India, diverse farm mechanization scenario in country due to varied size of the farm holdings and socio-economic disparities. Most of farmers in India are small and marginal land holder. The spraying operation done by rocker sprayer has some disadvantages like it consumes more time and energy, it cannot maintain required pressure, it leads to problems of back and solder pain. This equipment can also lead to misapplication of chemicals and ineffective control of target pest which leads to loss of pesticides due to dribbling or drift during application. In the view engine operated sprayer is better option due to its medium cost and small size implying in the small land holding. The engine operated sprayers can fulfill the mechanization gap to do spraying operation at the faster rate. This shows there is an urgent need to introduce mechanical sprayer in Indian farm. The engine sprayer should be easily manoeuvrable and less expensive for farmers or best source of power mechanical spraying operation.

The reviews from various journals it is clear that there is a scope for modifying this rocker sprayer as a mechanically operated one to overcome these difficulties of manual operations.

The global agricultural sprayer market is driven by factors such as innovations in agricultural sprayers, increased focus of the farmers to use modern tools, to increase the farm productivity, growing demands for different crops in the agricultural market, moreover government support for farmers in emerging market is likely to support the growth in this market over the forecast period. So, we can expect more market demand and value for a mechanically operated sprayer.

The idea of modification of sprayer to a reaper engine operated sprayer was by considering

- The reapers are not utilised at off season and hence combining it with sprayers can help in the utility of the reapers
- This ensures the effective usage of the sprayer and also the reapers can be used much effective to its price.

KAMCO power reaper is combined with the sprayer. KAMCO power reaper are one of the most popular reapers in Kerala and is ideally suited for harvesting of paddy, wheat and similar crops. It harvests and makes windrows at the rate of 3-4 hours per ha. Since fuel used is kerosene, cost of operation is the lowest. It cost around Rs.155000 per number.

To reduce the speed to suitable operating speed of sprayer, a reduction gear box is used (reaper operating speed 460 rpm is reduced to rocker sprayer operating speed 74 rpm)

The suitable ratio of reduction gear box is calculated as 6:1 by applying gear ratio Due to which there is a chance of pressure reduction.

□ The output getting will be in a rotational movement. But, we need a lateral movement of rocker sprayer. The mechanism connecting both rotational motion and lateral motion is slider-crank mechanism.

- So, a slider-crank mechanism is used here which is a typical design which converts rotary motion into linear motion. It is achieved by connecting a slider and a crank with a rod.

- There are two types of slider -In line -Offset

- Inline slider crank mechanism creates a symmetric slider movement back and forth as the crank rotates. While Offset slider crank mechanism is not symmetric and, it moves faster in one direction than the other.

- So, an inline slider crank mechanism is used here.

For the proper transfer of power from engine to the reduction gear box the connecting shaft is used and the shaft is designed and developed at the farm machinery workshop of KCAET.

The pistons linear motion is converted to rotational motion at the crank through a mutual link, referred to as the connecting rod. As the geometry of the crank forces the conversion of the linear motion in to rotational motion, shaking forces are generated and applied to the crank housing.

The crank, which is the rotating disc. The slider, which slides inside the tube and the connecting rod which joins the parts together. As the slider moves to the right the connecting rod pushes the wheel round for the first 180 degrees of wheel rotation.

The expected advantages of the reaper operated rockers sprayer are

- Using the reaper for spraying thereby utilising it at off season
- The machine is designed especially for orchards as it is expected to spray over a large area and up to a height of 30m since the motor operated was able to do for the height.
- A single person will be required for the operation and no much manual power would be required
- Since the tank is also attached to the frame so the difficulty in carrying is reduced
- The sprayer can either fixed to the frame or can be directed manually.
- It would be a much better ergonomically model.
- The reaper frame can be heavier and the model can be expensive but by modifying to a smaller model these problem can be avoided.
- It can reduce labour works and difficulties associated with manual working

4.1.2FUTURE SCOPES

- The entire model can be made smaller and there by its economic feasibility can be ensured.
- The introduction of artificial intelligence and sensors to the model
- Rectify the chance of pressure reduction because pressure is most important factor for working of the sprayer

CHAPTER V

SUMMARY AND CONCLUSION

- A reaper is a farm implement or person that reaps (cuts and often also gathers) crops at harvest when they are ripe. Usually the crop involved is a cereal grass. Most modern mechanical reapers cut the grass, most also gather it, either by windrowing it or picking it up.
- But even though, in the entire season the usage of reapers is only at the time of harvesting. This can lead to high maintenance which result in more maintenance cost. This also destroys the machines due to long time no use and rusting of parts. So in turn, it is not used effectively comparing its price. Hence at off season reaper can be utilised in some other way without altering its structure
- Detailed studies have done on different possibilities and need of mechanizations in agriculture field and finally we concluded that, agricultural spraying system is looking for modifications for their proper operations and prevention against attack of pests and insects
- By referring different journals and researches we found that manual operations with a rocker arm sprayer facing many problems that are,
 - it cannot maintain required pressure
 - it leads to problems of back and solder pain.
 - It may lead to misapplication of chemicals and ineffective control of target paste which leads to loss of pesticides due to dribbling or drift during application.
- Combining the rocker sprayer with the KAMCO power reaper can resolve the problems in the sprayer as well as the off season utility of the reaper.
- The reaper engine also gave extra benefits like,
 - frame consistency and stability
 - Easy to operate with less rpm
 - Speed is less enough to reduce in to matching speed of sprayer.

- The sprayer can be attached to this frame

- Speed of reaper engine is calculated using tachometer and it was found to be 460 rpm. Speed of rocker sprayer found as 74 rpm.
- A reduction gear box with 6:1 reduction ratio (determined from formula for gear ratio) is used to reduce the speed of engine from 460 rpm to 74 rpm.
- Machine is designed to a much ergonomical model as a single person operating up to a height of 30 m and covering a large area.
- The modified model offers some scopes for future agriculture,
 - entire model can be made smaller and there by its economic feasibility can be ensured.
 - introduction of AI and sensors to the model
 - Rectify the chance of pressure reduction because pressure is most important factor for working of the sprayer.

REFERENCES

- A. M. Michael and T.P. Ojha (2017), *Principles of Agricultural Engineering (volume 01)*, Jain Brothers Publications (fourth edition), New Delhi
- Saptashish Deb and Sonu kumar (2017), Modification and Testing of manually operated Rocker sprayer, *International Journal of Agriculture, Environment and Biotechnology*.
- Sivanainthaperumal.T, Selvam.M, Pandiyaraj.R and Arunraj.S(2018), Design and Development of Wheel Spray Pump, *International Journal of Agriculture, Environment and Biotechnology*.
- Pankaj B. Gavali (2018), A Review On Pesticides Sprayer Technology Approach in Ergonomics, Economics and Ecologic in Agriculture Field, *International Journal of Agriculture, Environment and Biotechnology*.
- Babasaheb Gholap and Ravi mathur (2013), Field evaluation of tractor operated boom sprayer of cotton crop, *International Journal of Agriculture, Environment and Biotechnology*.
- T. Subbarayudu and Dr. N. Venkatachalapathi ((2017), Modelling and development of pedal operated agricultural sprayer, *Australian journal of basic and applied sciences*.
- *En.m.wikipedia.org*

**DESIGN OF ENGINE OPERATED ROCKER SPRAYER WITH KAMCO
REPAER ENGINE AS THE PRIME MOWER**

BY
ANUSREE ARAVIND (2016-02-011)
JYOTHISH CHANDRAN (2016-02-021)
VISHNU GOPAL A (2016-02-047)

ABSTRACT OF THESIS
Submitted in partial fulfilment of the requirement for the degree of

BACHELOR OF TECHNOLOGY

IN

AGRICULTURAL ENGINEERING

(FARM MACHINERY POWER ENGINEERING)

Faculty of Agricultural Engineering and Technology

KERALA AGRICULTURAL UNIVERSITY



DEPARTMENT OF FARM MACHINERY POWER ENGINEERING
KELAPPAJI COLLEGE OF AGRICULTURAL ENGINEERING AND
TECHNOLOGY

TAVANUR - 679 573, MALAPPURAM

KERALA, INDIA

2020

ABSTRACT

A reaper is a farm implement or person that reaps (cuts and often also gathers) crops at harvest when they are ripe. Usually the crop involved is a cereal grass. Most modern mechanical reapers cut the grass, most also gather it, either by windrowing it or picking it up. Benefits of power reaper include they are simple to use controls *i.e.* Manual handling machine does not require separate machines for mounting. They are cost effective and saves time and are light weighted machine so that it is easy to handle. They are suitable for various crops like bengal gram, black gram, green gram, wheat, soybean mustard and paddy etc. But even though, In the entire season the usage of reapers is only at the time of harvesting. This can lead to high maintenance which result in more maintenance cost. This also destroys the machines due to long time no use and rusting of parts. So in turn, it is not used effectively comparing its price. Hence at off season reaper can be utilised in some other way without altering its structure.

There are many types of pesticides sprayer pump available in India. One commonly used sprayer is rocker type sprayer which is used by farmers because it is cheaper, easy to use, easily available and main thing about it is cost efficient. With the help of this machine, farmers spray pesticides in their farm, but it requires lot of time and thus high operational cost, low efficiency, health problem and low profit. Also, the farmer which is spraying pesticides is affected by it as it is harmful to human health. And also it requires high manual power to maintain required pressure. That leads to problems of back and solder pain. Taking these problems in view, rocker arm sprayer was selected and modified to a much more ergonomical model. Reaper engine was selected which was attached the rocker sprayer to form the engine operated sprayer. Hence combining the KAMCO power reaper with rocker sprayer can resolve the problems of both the equipment.

The rpm obtained at the gear output of the reaper is 460 rpm but the required rpm for the rocker sprayer operation is 74 rpm (average). To acquire this a reduction box is required with a reduction ratio of 6:1 and hence a reduction box is to be developed. The power from engine is supplied to rocker sprayer using a slider crank

mechanism with the length of two linkages as 4.5 cm and 13 cm. The reduction box is attached to the gear output with a shaft. This model is expected to reduce the problems like high manual power requirement for the operation that may lead to back pain and shoulder pain and also for easy transportation and operation of the sprayer by a single person.