

**DEVELOPMENT OF AUTOMATED DRIP FERTIGATION SYSTEM  
USING GSM BASED CONTROLLER**

**by**

**P. AKHILA SHINEY**

**(2017-18-015)**

**THESIS**

**Submitted in partial fulfilment of the requirements for the degree of**

**MASTER OF TECHNOLOGY**

**IN**

**AGRICULTURAL ENGINEERING**

**(Soil and Water Engineering)**

**Faculty of Agricultural Engineering and Technology**

**Kerala Agricultural University**



**DEPARTMENT OF SOIL AND WATER ENGINEERING**

**KELAPPAJI COLLEGE OF AGRICULTURAL ENGINEERING AND  
TECHNOLOGY**

**TAVANUR – 679573, MALAPPURAM**

**2019**

## **DECLARATION**

I, hereby declare that this thesis entitled “**DEVELOPMENT OF AUTOMATED DRIP FERTIGATION SYSTEM USING GSM BASED CONTROLLER**” is a bonafide record of research done by me during the course of research and the thesis has not previously formed the basis for the award to me of any degree, diploma, associateship, fellowship or other similar title, of any other University or Society.

**Place: Tavanur**

**Date:**

**P. Akhila Shiney**

**(2017 - 18 - 15)**

## **CERTIFICATE**

Certified that this thesis entitled “**DEVELOPMENT OF AUTOMATED DRIP FERTIGATION SYSTEM USING GSM BASED CONTROLLER**” is a bonafide record of research work done independently by **Ms. P. Akhila Shiney (2014-18-15)**, under my guidance and supervision and that it has not previously formed the basis for the award of any degree, diploma, fellowship or associateship to him.

**Place: Tavanur**

**Date:**

**Dr. Sajeena, S**  
(Major Advisor, Advisory Committee)  
Assistant Professor  
ICAR Krishi Vigyan Kendra,  
Malappuram

## **CERTIFICATE**

We, the undersigned members of the advisory committee of **Ms. P. Akhila Shiney (2017-18-015)** a candidate for the degree of **Master of Technology in Agricultural Engineering** with major in Soil and Water Engineering, agree that the thesis entitled **“DEVELOPMENT OF AUTOMATED DRIP FERTIGATION SYSTEM USING GSM BASED CONTROLLER”** may be submitted by **Ms. P. Akhila Shiney (2017-18-015)**, in partial fulfilment of the requirement for the degree.

**Dr. Sajeena, S**  
(Chairman, Advisory Committee)  
Assistant Professor  
ICAR Krishi Vigyan Kendra Malappuram  
Tavanur, Malappuram

**Dr. Sathian K.K**  
(Member, Advisory Committee)  
Dean, Professor and Head  
Dept. of SWCE,  
KCAET, Tavanur

**Dr. Abdul Hakkim V.M**  
(Member, Advisory Committee)  
Professor (SWE)  
Dept. of Agricultural engineering  
CoA, Paddannakad, Kasargod

**Er. Shivaji K P**  
(Member, Advisory Committee)  
Assistant Professor  
Department of FPME  
KCAET, Tavanur

**EXTERNAL EXAMINAR**  
(Name and Address)

## **ACKNOWLEDGEMENT**

*It is a matter of deep privilege to express gratitude and indebtedness to **Dr. Sajeena, S**, Assistant Professor, ICAR Krishi Vigyan Kendra Malappuram, Tavanur, for her valuable guidance, constructive criticism, caring and constant encouragement during the research work and provide good atmosphere for doing research and in the preparation of manuscript.*

*I express my earnest thanks to **Dr. Sathian K.K**, Dean, KCAET, Faculty of Agricultural Engineering and Technology, for the unfailing guidance and support that he offered while carrying out the project work.*

*I express my heartfelt thanks to **Dr. Abdhul Hakkim, V.M**, Professor, Department of Agricultural Engineering, College of Agriculture, Padannakkad, Kasargod for the valuable advices, encouragement, since help and co- operation towards me for the evaluation of my thesis.*

*I engrave my deep sense of gratitude to **Er. Shivaji, K. P**, Assistant Professor, Department of FPME, KCAET, Tavanur, for his valuable suggestions, evaluation and due encouragement during the entire period of the project work.*

*It is my pleasure to offer whole hearted thanks to **Dr. Habeeburrahman P. V.**, Retaired Professor and Head, KVK Malappuram **and other staff members of Krishi Vigyan Kendra, Tavanur** for giving valuable suggestions and better environment during all stages of this research work.*

*I express my thanks to **Mr. Harrish** reference Librarian, and all other **staff members of Library**, KCAET, Tavanur for their ever willing help and cooperation.*

*With great pleasure I express my heartfelt thanks to all teachers of KCAET Tavanur for their support during my thesis work.*

*It gives me immense pleasure to express my deep sense of gratitude to **Mr. Aneesh Kumar**, Manager, Invade Technologies, Kannur, for his valuable support and advice throughout the project work. My heartfelt gratitude to **Ms. Shijila and Mr. Unnikrishnan**, Lab Assistants.*

*I like to mention heartfelt thanks to my seniors **Er. Navneet Sharma, Er. Arjun Prakash K.V., Er. Ajay Gokul and Er. Jyothi Narayan** for their timely help and support rendered to this work.*

*My sincere thanks are extended to **my batch mates** at KCAET for their remarkable co-operation and encouragement to me during the tenure.*

*I express my sincere thanks to **my juniors** for their valuable support during the research period.*

*I express my deep sense of gratitude to **my loving parents and family members** for their continuous support and inspiration all through my studies.*

*Above all, I bow my head before **God Almighty** for the blessing and procurement bestowed on me to complete this work.*

**P. Akhila Shiney**

## CONTENTS

<b>Chapter No.</b>	<b>Title</b>	<b>Page No.</b>
	LIST OF TABLES	I
	LIST OF FIGURES	II
	LIST OF PLATES	IV
	SYMBOLS AND ABBREVIATIONS	V
1	INTRODUCTION	1
2	REVIEW OF LITERATURE	5
3	MATERIALS AND METHODS	22
4	RESULTS AND DISCUSSIONS	50
5	SUMMARY AND CONCLUSION	71
	REFERENCES	74
	APPENDICES	82
	ABSTRACT	94

### LIST OF TABLES

Table No.	Title	Page No.
1	Pin description of LCD module	29
2	Fertigation treatments	47
3	Calibration values of capacitance soil moisture sensor	53
4	Calibration data of capacitor sensor in laterite soil	54
5	Calibration data of capacitor sensor in black soil	54
6	Calibration data of capacitor sensor in coastal alluvium soil	54
7	Values of field capacity and permanent wilting point	57
8	Growth parameters after DAP	59
9	Plant height during the crop growth period	61
10	Number of leaves during the crop growth period	61
11	Stem girth during the crop growth period	61
12	Growth parameters of chilli crop (last observation)	63
13	LSD test for treatments based on plant height	64
14	LSD test for treatments based on number of leaves	64
15	LSD test for treatments based on stem girth	64
16	Yield parameters of chilli crop (last observation)	65
17	LSD test for treatments based on number of fruits/plant	67
18	LSD test for treatments based on fruits length (cm)	67
19	LSD test for treatments based on yield per plant (kg)	67
20	Comparison of cost economics of different irrigation methods	69



### LIST OF FIGURES

Figure No.	Title	Page No.
1	Block diagram of automated drip fertigation system	24
2	Contact of probes with water ions	25
3	Circuit of capacitor type soil moisture sensors	26
4	Pin diagram of microcontroller unit	27
5	Circuit diagram of HD (44780) (LCD module)	29
6	Circuit of control keys	30
7	Circuit of relay circuits	32
8	Block diagram (power supply)	33
9	Circuit of GSM modem	34
10	Circuit of serial interface to GSM modem	34
11	Field layout	44
12	Sieve analysis of laterite soil	50
13	Sieve analysis of black soil	50
14	Sieve analysis of coastal alluvium soil	51
15	Particle size distribution curve of laterite soil	51
16	Particle size distribution curve of black soil	52
17	Particle size distribution curve of coastal soil	52
18	Calibration curves of capacitance sensors in laterite soil	55
19	Calibration curves of capacitance sensors in black soil	55

20	Calibration curves of capacitance sensors in coastal soil	55
21	Status message from the system before irrigation	58
22	After irrigation status	58
23	Fertigation scheduling status	58
24	Variation in plant height of different treatments	62
25	Variation in number of leaves of different treatments	62
26	Variation in stem girth of different treatments	62
27	Variation in number of fruits of different treatments	66
28	Variation in fruit height of different treatments	66
29	Variation in yield/plant of different treatments	66

### LIST OF PLATES

<b>Plate No.</b>	<b>Title</b>	<b>Page No.</b>
1	Capacitor type soil moisture sensor	28
2	Board with microcontroller	28
3	Liquid crystal display	31
4	Control keys	31
5	Centre tap transformer	35
6	IC voltage regulator	35
7	GSM modem connection	35
8	Electronic fertilizer injection pump	38
9	Electronic fertilizer mixing device	38
10	Arrangement of solenoid valves in main pipe	37
11	Calibration of capacitance sensor with different moisture contents	45
12	Field preparation	45
13	Beds covered with mulching film	45
14	Chilli in nursery	45
15	Planted condition in an open field	45
16	Pressure plate apparatus	46
17	Ceramic Plate (15 bar pressure)	46
18	Ceramic plate (1 bar pressure)	46
19	Evaluation of capacitor type sensor	59
20	Stages of plant growth	60
21	Comparison of fruit size	68

## SYMBOLS AND ABBREVIATIONS

Symbol	Abbreviation
Ac	Alternating current
ADC	Analog to digital converter
BIT	Binary digit
Cm	Centimeter
DAP	Day after planting
DC	Direct current
°C	Degree centigrade
dS/m	Desisiemens per meter
EC	Electrical conductivity
FC	Field capacity
FIG	Figure
GPRS	General Packet Radio Service
GSM	Global system for mobile communication
HP	Horse power
i.e.	That is
Kg	Kilogram
kg/ha	Kilogram/hector
LCD	Liquid crystal display
LDPE	Low density poly ethylene
MCU	Microcontroller unit
Min	Minute
Ml	Milliliter
Mm	Millimeter
Mm	Micrometer
NPK	Nitrogen, Phosphorous, Potassium
PET	Potential evapotranspiration
PIC	Peripheral interface controller
PIN-DIP	Dual inline pin package

Ppm	Parts per million
PVC	Poly vinyl chloride
PWP	Permanent wilting point
RAM	Random access memory
ROM	Read-only memory
SIM	Subscriber identity module
SP	Saturation percentage
TDR	Time- domain reflectometer
UART	Universal asynchronous receiver transmitter
V	Volt
WSN	Wireless sensor network
F	Farad
LSD	Least Significant Difference
KAU	Kerala Agricultural University

## CHAPTER 1

### INTRODUCTION

Lack of sufficient water to grow enough crops for meeting the food demand of the increasing population is the major threat of Indian agriculture. With the increase in the demand for crop in quantity, quality of production and rising concern of non-point soil pollution caused by advanced farming practices, the capability and environmental safety of agricultural crop production systems have been questioned (Cristian *et al.*, 2014). The condition became critical, due to the rapid rise in demand for water resources along with population growth, urbanization and industrial uses. Agriculture sector is the largest water consumer (84%) in India; more judicious use of water in agriculture for crop production needs to be the first priority (NITI Aayog, 2015). By the 21st century, Forecasted meteorological records explain increase in earth's temperature and decline in annual rainfall, leads to depletion in available water resources (Turrall *et al.*, 2011).

According Mark et al. (2002), about 33% of India's population will face severe water scarcity condition by the year 2025. The per capita water accessibility in terms of average utilizable water supply within the country was  $6008\text{ m}^3$  in 1947 and is predicted to decline to  $760\text{ m}^3$  by 2025. The condition of life on earth is ever-changing yearly and conjointly increases in basic transformations of environment, due to rapid rise in human civilization and modern scientific and technological transformations. The population growth in India is about 2% per year, for providing essential food intake the food production should rise about 2.5% per year (Patil *et al.*, 2014). The main reason for low coverage of irrigation is prevailing use of traditional method of irrigation, where water saving and water use efficiency is extremely low. The water use efficiency of surface flooding or traditional method of irrigation is only about 35 to 40 percent because of massive conveyance and distribution losses.

The surface irrigation techniques cause seepage losses, erosion and water logging problems, deep percolation, salinisation and runoff. To get satisfactory growth, application of right quantity of water at right time and at right place is very important and this can be accomplished only through micro irrigation techniques (Arjun Prakash *et al.*, 2017). The most accepted micro irrigation system at current scenario is drip irrigation technique; it has the potential to save irrigation water and fertilizers by applying water directly to the root zone area of the plants and minimizing the evaporation. The loss of fertilizer is reduced due to the precise application and minimized leaching. Drip irrigation system is designed and invented to sustain crop growth in arid and semi- arid regions and in greenhouses. Micro irrigation requires substantial initial investment and as a result, this system is appropriate for high value horticultural crops, fruits, vegetables, cut flowers and ornamentals.

Over 70 per cent of the rural households depend on agriculture for their livelihood in India. The cultivated land in India is 160 million hectares; in this 39 million hectare land area was irrigated with groundwater through wells and 22 million hectares was irrigated by irrigation canals. In 2010, only about 35% of agricultural land in India was reliably irrigated. Distribution of the limited available water resources over the massive expanse of the country is uneven. Tata Institute of Social Sciences (TISS) survey reveals that most of the urban cities are facing critical water deficient. In India people from urban area consumes nearly 50% of water from ground water through wells (TISS 2017).

As a result the ground water tables are falling every year about 2 to 3 m in most of the cities. As per the study conducted by the Central Ground Water Board (CGWB) in 2011 explains, in India annual rechargeable groundwater resource is around 433 billion cubic meters (BCM) and net annual ground water accessibility is 398 BCM of which India is annually evacuates 245 BCM (62%). As stated by the CGWB, around 39 per cent of the ground water wells are broadcasting depletion in water level and a survey conducted reveals that groundwater level in Kerala is falling 0.2 to 0.5 metres every year, indicating a rising trend of over-

exploitation and the lack of recharging facilities. One of the consequences of over exploitation of groundwater is the pressure that is put on accessible groundwater resources to assist an increasing population. Indian agriculture faces more challenges for the production of safe and quality food. Sometimes it can cause demerits like wilting of plants by the over application of water and lead to pollution of the environment by fertilizer application doses higher than recommended. Hence new innovations are developed in such a way that it should be both ecofriendly and accepted by marginal farmers. The present micro irrigation systems introduce automation in drip irrigation using enlightened equipments to provide water and fertilizers to the crop according to crop requirement. Automation in drip irrigation technique improves crop production, water saving and labour costs when compared to manual irrigation systems.

The sensor based irrigation for measuring soil moisture content are using for decades. Advanced soil moisture sensors determine volumetric water content of the soil at the root zone area by measuring capacitance of the water and dielectric constant. The involvement of sensors, irrigation valves, fertigation system, microcontroller unit and motor in the automated drip system can provide optimum crop growth by maintaining field capacity at the root zone area. By interfacing microcontroller with GSM module in the automated irrigation can update status of the irrigation system and motor to the concerned mobile phone user. And installation of LCD board in the microcontroller unit to display moisture content data provided by the sensor. LCD display can help the user to collect different feedback from different types of soil moisture levels from various locations in the cultivated land.

To get better crop growth and yield, the nutrients are essential. The application of solid fertilizers through broadcasting will decrease the fertilizer use efficiency and fertilizer saving, this may lead to poor crop productivity. Fertigation is a process of applying water soluble fertilizers through drip irrigation system. Improvement of fertilizer application with automated drip system such as fertigation automation is important to maintain the nutrient balance at crop root



zone to enhance the better crop growth. In addition, sustainable agriculture is important by providing fertilizers according to crop requirement to minimize the soil pollution. By using positive displacement pumps and irrigation controllers to supply water soluble fertilizers can be automated through notable time management to get essential crop growth and yield.

Almost all the existing drip automation system in the country, take care of automation of irrigation component and not the fertigation part. In general, automation of fertigation system is costly and not affordable by the marginal farmers due to the high initial investment. Sensor based fertigation automation has number of limitations and not used by the farmers. Development of sensor based fertigation system is tedious, costly, time consuming and may lead to wrong scheduling of fertigation due to the variations occurring in the soil other than that due to change in the nutrient status. In order to get popularity and wider adoption of automated drip fertigation system, it is essential to bring out a cost effective system. The present study aims to design and develop a cost effective user friendly automated drip fertigation system using GSM, with soil moisture sensors for irrigation automation and timer for fertigation automation.

Therefore, the present work is proposed for the design and development of GSM based automated drip fertigation system with the following objectives.

1. To design and develop a GSM modem based drip fertigation automation system.
2. To evaluate the performance of the developed automated drip fertigation system with solenoid valves and GSM based micro controller using digital device (mobile) in the laboratory.
3. To evaluate the performance of the developed sensor based drip fertigation automation system for a short duration vegetable crop (chilli).

## CHAPTER 2

### REVIEW OF LITERATURE

This chapter reviews the concepts and literatures available on soil properties on drip irrigation, automation of drip fertigation system and related aspects. Use of automated drip fertigation technique improves the fertilizer and irrigation water use efficiency and targets at increasing farmer's income and reduces the soil pollution. Drip fertigation system provides various advantages such as precise application of water and fertilizers according to crop requirement, reduces the salinization and ground water pollution, decreases the fluctuation in fertilizer concentration in soil during the crop growing season and permits easy use of soluble solids as well as balanced liquid fertilizer and micronutrients.

#### 2.1 Soil moisture content

Soil-water content is a measure of the amount of water (volume or mass) contained in a unit volume or mass of soil. The soil moisture content may be present in the soil as adsorbed moisture content and capillary condensed moisture in tiny pores. Water content in the soil has major role for groundwater recharge, agriculture production and soil chemistry. The moisture content in the soil should be optimum for the plant growth for all crop stages. Today a large number of soil moisture sensors based on different methods are available for measuring soil moisture and also temperature (Tyronese Jackson *et al.*, 2007).

##### 2.1.1 Field capacity

Field capacity is the moisture content of a soil, expressed as percentage of oven dry weight, after gravitational or free water has been allowed to drain, usually 24 to 36 hours after flooding (Michael, 2017). It is approximately similar to the moisture equivalent or 0.33 atmosphere percentage. The field capacity can be calculated by using pressure plate apparatus at 0.3 bar pressure.

Mbah, C.N. (2012) conducted a study on field capacity (FC) and permanent wilting point (PWP) by using saturation percentage (SP) and observed

that soil moisture content at field capacity (FC) and permanent wilting point (PWP) is necessary for irrigation scheduling, assessing crop water requirement and estimating soil suitability for different land uses. Results of the study concluded that the soil moisture constants (FC and PWP) could be determined using SP while total available water capacity and readily available water capacity cannot be estimated using SP for the soil selected in this study.

### **2.1.2 Permanent wilting point**

The permanent wilting point (PWP) is the moisture content of the soil, expressed as percentage of the dry weight, at the time when the leaves of the plant growing in the soil first undergo a permanent reduction in their moisture content, as a result of the deficiency in the soil moisture supply (Michael, 2017). The soil moisture tension at PWP varies from 7 to 32 atmospheres, depending on soil texture, condition of plants, and on the amount of salts in the soil solution. Fifteen atmosphere percentage is the value commonly used for this point.

### **2.1.3 Available moisture content**

The difference in the moisture content of the soil between field capacity and the permanent wilting point is called the available moisture. This indicates the moisture content which can be accumulated in the soil for subsequent use by the crop. In addition to moisture tension and osmotic pressure of the soil, the availability of water also depends on the temperature of the soil. Low soil temperatures decrease moisture accessibility.

The development of a proper crop rooting system and the uptake of the required amount of water content from the soil are critical at every stage in plant growth. Too much or too little soil moisture content can have direct effect on yield and fruit production. When the soil moisture exceeds the field capacity, it causes water logging on the surface of the soil and depresses oxidative has been drained by gravity (Hason *et al.*, 2004). On the other hand, if the moisture content drops to a level below the permanent wilting point, then the crop rooting system cannot extract the moisture from the soil, because the soil is too dry.

## **2.2. Measurement of soil moisture content**

### **2.2.1. Direct method (Gravimetric method)**

The most appropriate direct method of soil moisture measurement involves removing the moisture content by heating the soil sample at 105°C in the oven about 24 hours. The accuracy of the gravimetric method depends on the accuracy of weighing the soil sample. However, these errors are negligible in relation to soil variability in the field (Campbell and Mulla, 1990). The soil water content will be indicated in the form of per cent water by volume or centimetres of water per meter depth of soil. The gravimetric method is cost effective, easy to handle and accurate, but it is time consuming, detrimental and complex to use with rocky soils. The use of gravimetric method is difficult with heterogeneous soil profiles.

While this method is fairly accurate and also there are practical issues which may prevent its use for irrigation scheduling. And also this method gives the results after 24 hours. While gravimetric method requires auger sampling for measuring soil moisture content of the soil, but the volumetric soil content requires sampling cylinders for sampling the known volume to calculate the soil bulk density.

### **2.2.2 Indirect methods**

Sophisticated equipment's and soil moisture sensing techniques were used for the indirect determination of soil moisture content. These two methods can be broadly classified based on the two principles; those are dielectric properties of soil and electrical conductivity. In the earlier stages the soil moisture instrument tensiometer reads the soil tension or metric potential corresponding to the moisture level in the soil. It has merits like easy handling, not much expensive and less time consuming. The tensiometer was used widely by the farmers because of these merits in for measuring the soil samples (Campbell and Mulla, 1990).

### **2.2.2.1. Capacitance**

There are number of methods and techniques for measuring the soil moisture content. But for getting precise and accurate results the capacitance probe is more efficient to use for soil moisture measurements. The capacitance probe is sensitive, light weight, economical in construction and quick in use. The capacitance probe also responds to the minimum soil content and gives the accurate results in less time (Dean *et al.*, 1987).

The capacitance probes are nondestructive and less tedious and root zone area of the crop in the entire soil profile can continuously monitored by the capacitance sensors. Soil moisture content in the root zone area of the crop was measured by using laboratory techniques. But by using capacitance probes the soil moisture release curves and water redistribution in the field was measured (Ali *et al.*, 2000).

Zotarelli *et al.*, (2010) stated that the recent advanced technologies on sensing the soil moisture content provides the real-time interpretation on the result of irrigation management on the actual soil moisture status. Capacitance-based soil moisture measurement techniques show relatively accurate results with low maintenance. The soil moisture capacitance probes were effective at decreasing irrigation water and nutrient leaching.

Wang (2014) reported that the capacitive sensor technology is used in the field of gesture proximity detection, material analysis and sensing of moisture content level. The advantages of the capacitance sensors are small in size and can sense large areas, cost effective and minimum power consumption. Topology of the capacitance probe relies on the dielectric property of the soil and sensitivity.

### **2.2.2.2. Electrical Conductivity**

Soil salinity has notable effect on the physical, chemical and biological properties of the soil. The some soil types are moderately saline, if the EC of the soil is greater than 2dS/m. For proper plant growth and micro activity in the soil

the EC value should be in between 0 and 1.5 dS/m, but the EC value may vary for specific land types and some crops can tolerate highest salt concentrations. More content of EC in the soil content results in potential loss for  $\text{NO}_3^-$ -N and this may cause surface and subsurface water resources contamination (John *et al.*, 1996).

Determination of relation between volumetric moisture content of the soil and EC of the soil sample was used for the mapping of field capacity over a field. Additionally, the method derives the relationship between electrical conductivity (EC), pH and other soil test parameters (Morgan *et al.*, 1998).

Kuligod *et al.*, (1999) defines that necessary calibration and development is needed to derive the EM38 equation for quick diagnostic soil salinity surveys in country. The appliance of EM-38 equation has not accumulated in India because of the more instrument cost. The application of this equation is proscribed to mapping the saline lands.

Bristow *et al.*, (2001) conducted an experiment by installing developed multi-needle sensor probe in the soil profile and calculated the EC of bulk soil. The probe is small in size, so it can accurately measure the soil moisture at near the soil surface, near to root zone area of the crop and it can also use fine spatial resolution. As a function of time and space the multi-needle can easily incorporate with automation to provide collected data. The advantage of the probe is it provides the temperature and water content together with the electrical conductivity, all at the same position within the soil profile, and for most practical purposes, at the same time.

### **2.3 Particle size analysis**

Particle size analysis (PSA) is a measurement of the size distribution of individual particles in a soil sample. The main characteristics of particle size analysis are the separation of the soil aggregates into individual particles by chemical, mechanical or ultrasonic means and the dispersion of soil particles according to size limits by such means as sieving and sedimentation.

### **2.3.1 Sieve analysis**

For sieve analysis the soil samples are collected from different locations in the field are dried in an oven for 24 hours. In the fine analysis soil samples were kept in sieve size of 2mm placed above 1mm, 600, 425, 300, 212, 150, 75 microns and a retainer arrangement. The sieves should be mechanically oscillated for 10 min according to the type and texture of the soil. Weigh the each sample carefully which is retained in the sieve. In the case of coarse analysis, the soil samples were carried out in 100mm, 63mm, 20mm, 10mm, 4.75mm sieves and a retainer (Punmia *et al.*, 1994; 2005).

### **2.3.2. Sedimentation analysis**

The sedimentation analysis to find out the distribution size soil samples contains organic matter less than 5%. The analysis requires 2-2.5 hour time for each soil sample, so the several hydrometers were used for testing the more soil samples at a time. The procedure includes the separation of coarse particles from the samples greater than 2mm by sieving and weighs the remaining fine textured particles. Make sample solution by adding 250ml of distilled water into 50g soil sample which is taken in the dispersion cup and solution was mixed thoroughly for 15 min. Transfer the entire solution into a cylindrical flask and add water up to 1 litre for dilution. Mix the solution thoroughly using plunger and take the reading randomly using hydrometer at 40 sec and after 2 hours (SFU soil science, 2012).

### **2.4. Drip irrigation system**

The most accepted micro irrigation technique is the drip irrigation for applying irrigation water and nutrients efficiently to the root zone area of the plant according crop water requirement. The drip irrigation technique can significantly improve the crop growth and yield by providing uniform water and nutrients directly to the root system. This will improve the water saving and fertilizer efficiency and thereby reduce the weed growth.

Nazirbay *et al.*, (2007) conducted an experiment on cotton crop by using 70%, 70% and 60% FC rule for drip irrigation and surface irrigation. The resultant water use efficiency was high about 71% from the drip irrigation system as compared to surface or traditional method of irrigation. And also the cotton crop yield increased up to 14% compared furrow irrigated cotton. Hence, the treatment 70-70-60% of FC from drip irrigation technique gave the 32% of irrigation water saving when compared to traditional method of irrigation.

A study was conducted to investigate the effects of drip irrigation techniques in solar green house and also different irrigation levels were observed based on quality, crop yield and water use characteristics of lettuce crop. The result showed that the largest production was obtained from 100% Class 'A' pan evaporation rate and subsurface drip irrigation system at 10 cm drip line depth. The irrigation use efficiency increased as the minimized irrigation application rate (Bozkurt *et al.*, 2009).

Vijayakumar *et al.* (2010) conducted an experiment to increase the irrigation water and nutrient use efficiency on brinjal crop at agricultural research station, Bhavanisagar. The study consists of nine treatments and includes three fertigation levels 75, 100 and 125 percent by the use of recommended quantity of potassium and nitrogen through drip irrigation system and three irrigation levels 75, 100 and 125 per cent. This study revealed that 75 percent irrigation through drip and 75 percent fertigation shows increased water use efficiency also increases crop yield up to 111.5 kg/ha and according to crop recommendation the application of 75 percent fertilizer through fertigation gives increased crop shoot length and more number of branches per plant.

To optimize the yield of maize crop, an experiment was conducted to determine the ideal irrigation scheduling and injecting fertilizers through drip irrigation method. Four irrigation levels (0.6, 0.8, 1.0 and 1.2 at crop evapotranspiration) and two fertigation timings (fertilizer dose in 60 and 80% of the irrigation time) were finalized in a split-plot design. The results showed that



efficient irrigation and fertilizer application based on crop requirement increased the vegetative growth and yield. The treatments 1.2 and 0.6 crop evapotranspiration show the highest and lowest crop growth and yield. The treatment at 0.8 crop evapotranspiration and 80% fertilizer application gave the highest water use efficiency and saved the 27% of the irrigation water (Mahmoud Ibrahim *et al.*, 2015).

#### **2.4.1. Fertigation**

Efficient crop production requires proper utilization of soil water content and fertility. Placement of fertilizers in the correct zone of moisture availability is important to maximize fertilizer efficiency. Fertigation is the method of application of water soluble fertilizer with drip irrigation system. Since the wetted soil volume is limited, the root system is confined and concentrated. The nutrients from the root zone are depleted quickly and a continuous application of nutrients along with the irrigation water is necessary for proper plant growth. Fertigation offers precise control on fertilizer application and can be adjusted to the rate of plant nutrient uptake.

Hebbar *et al.*, (2004) conducted an experiment on tomato crop by using drip irrigation and observed that application of water soluble fertilizers significantly increased the tomato yield up to 33%. And also increased leaf area index, dry matter production, more number of fruits per plant and improved fertilizer use efficiency using drip irrigation system. The precise fertilizer application reduced the nutrient leaching.

A study conducted by using drip fertigation system in arecanut results in increased crop yield and high fertilizer use efficiency with 75% NPK at 10 days interval. Thus, applying water soluble fertilizers through drip system has number of advantages due to elevating water scarcity and increasing cost of fertilizer. By using drip fertigation system one can minimize the fertilizer usage and reduced soil pollution (Ravi *et al.*, 2007).

A field experiment was conducted on the green pepper (*Capsicum annuum*, L.). The study consists of three irrigation treatments (50%, 75% and 100%) using evapotranspiration and two planting methods, normal and paired-row planting. The results from the paired row planting for green pepper by using 75% irrigation was increased plant height, crop yield and number of fruits per plant were highly significant ( $p < 0.01$ ) and number of primary and secondary branches per plant were affected significantly ( $p < 0.05$ ). The results showed that the paired-row planting method gave the highest yield and improved plant growth at 75% irrigation water and also 25% water saving (Takele Gadissa *et al.*, 2009).

Jayakumar *et al.*, (2014) conducted an experiment on BT cotton and results showed that the combination of 150 % water soluble fertilizer using drip fertigation and the biofertiagtion of azophosmet @ 250 ml diluted in 100 litres of water/ha gave the highest in the BT cotton. In semi arid tropic areas, the combination of drip fertigation and biofertilizers for crop growth according crop demand results in reduced salinization, minimized nutrient concentration fluctuation in the soil during the crop period, higher nutrient use efficiency and increased crop yield.

#### **2.4.2 Sensor based irrigation**

Eller *et al.*, (1996) stated that, the thermo gravimetric method is extremely time consuming to remove the moisture content in the soil samples. The developed battery-powered portable dielectric probe based on measurement of impedance can detect the soil moisture content precisely within a short time when compared with standard methods.

All the operations such as effective monitoring and sending commands were efficiently controlled in drip irrigation system using ZigBee technique and it was a real time feedback control system. This technique will rationalize the agriculture sector and irrigation control. Zigbee is one of the best automation technologies to control the irrigation in big agricultural lands to improve the crop productivity (Awati *et al.*, 2012).

The surface flooding or traditional method of irrigation requires lot of water to irrigate the entire, but the spacing in between two rows of any crop remains dry and gets required amount of moisture only from the subsidiary rainfall. The drip irrigation technique is one of the micro irrigation methods and applies water directly to the crop root zone area according to crop water requirement. By using fuzzy time-series based algorithm in WSN in drip irrigation system can control the excess water and improves the crop yield and quality. (Sukhjit and Neha., 2012).

Kontantinos *et al.*, (2015) conducted a study on soil moisture sensors positioning in the field and sensing accuracy based on irrigation scheduling and observed that, based on the soil moisture content the soil moisture sensors positioning and accuracy using drip irrigation method at different conditions (type of the soil, PET, discharge and irrigation depth) was examined using a mathematical model, it integrates hysteresis in the soil-water characteristic curve, evaporation from soil, and soil water withdrawal by the roots. From this study the features of certain crops, irrigation systems, and soil moisture sensors will contribute a sound knowledge for upgraded irrigation scheduling.

### **2.4.3. Comparison and calibration of sensors**

White *et al.*, (1994) predicted the influence of dielectric losses on TDR determinations of soil water content in porous materials and compared predictions with measurements. A three phase effective model was modified to show how dielectric constant and water content without evoking bound water. This equation was tested using graphite sand mixture in which electrical conductivity varied systematically.

Evans *et al.* (1996) stated that most of the soil moisture estimating instruments comes with calibration curve. For getting accurate measurements, the soil moisture probe should be calibrated for all type of soils in each irrigated fields. The calibration is to establish the specific relationship between the plant

available water (PAW) on a soil site with the readings of the soil water measuring device.

Shock *et al.* (2001) differentiated six soil moisture probes and their performances in soil moisture content. The sensors were Aquaflex, Gro Point, Moisture Point, Neutron Probe, Tensiometer and Watermark. All moisture sensors revealed correlations ( $r^2 > 0.7$ ) to the neutron probe and correlations ( $r^2 > 0.5$ ) to the tensiometer probe excluding the moisture point sensors. The estimation of soil moisture content was extremely low in moisture point sensor than neutron probe. The tensiometer and Watermark probes responded to wetting and drying cycles of the soil. The neutron probe and Aquaflex sensors showed less reaction to the soil.

Heng (2003) carried out numerous comparisons on a wide range of sensors soil moisture neutron probe, Time Domain Reflectometer and capacitance probes. The soil moisture sensors were tested using a various soil types, vegetation and experimental fields, under irrigated and rain fed conditions in an open field and in laboratory and the soil temperature and soil salinity were analysed. After comparison, it was revealed that all the soil moisture probes require specific calibration excluding conventional TDR probe which can be used accurately without calibration.

#### **2.4.4. Automated drip irrigation**

Nemali *et al.*, (2006) conducted a study on automated system for controlling drought stress and irrigation in potted plants. This system can reduce the wastage of irrigation water due to excess application, leaching and run-off. Using this automated micro controller with bedding plants, we can control the excess water available in soil and reduced stress on the plant.

A study conducted on dwarf cherry plants by using a WSN. The developed automated drip irrigation system is cost effective, easy to handle and can be used in various commercial agricultural productions. The WSN based automated drip irrigation system has more advantages such as reducing moisture stress on plants, minimizing excess water use, and decreasing salification. The developed

technique can also provide fertilizer and pesticides to the crop using nutrition sensors (Mahir *et al.*, 2011).

Prathyusha *et al.*, (2012) reported that the Microcontroller based drip irrigation system proves to be a real time feedback control system which monitors and controls all the activities of drip irrigation system efficiently. The developed system is a model to modernize the agriculture industries at a mass scale with optimum expenditure. They can provide irrigation to larger areas of plants with less water consumption and lower pressure. Using the automated drip system, one can save manpower, water to improve production and ultimately profit.

A computer based automated drip fertigation system was developed, automatically to apply the irrigation water directly into the crop root zone. The developed system can optimize the distribution of water to stimulate the crop growth and yield and to intensify the crop production efficiently. So the drip irrigation/fertigation based on automation can enhance the crop productivity by applying water precisely to the crop root zone and reduces the wastage of water and fertilizer (Guerbaoui and El afou., 2013).

Sharma *et al.*, (2015) developed an automated drip irrigation technique using conductive type and capacitor type soil moisture sensors and analysed the performance of soil moisture sensors using the relationship between soil moisture content and electrical conductivity. The three conductive soil moisture sensors and one capacitor soil moisture sensor were used in the field with amaranths crop and it was observed that the system works automatically according to the pre-set limits of moisture content and motor was switched ON and OFF automatically.

Osroosh Yasin *et al.*, (2016) introduced seven irrigation scheduling algorithms contains two well-known plant/ thermal-based approaches of the Time and Temperature Threshold (TTT) and Crop Water Stress Index (CWSI). A WSN was done the irrigation automatically in an apple orchard to 21 management zones. The experimental results promoted the use of weather- and plant-based algorithms, decision support and monitoring software and WSN for automatic

irrigation management in the apple orchard, it leads to sufficient water to the plants and reduced water stress. The developed system can increase the water use efficiency, improve production and increased quality.

#### **2.4.5. Automated drip fertigation system by time basis**

Hasan *et al.*, (2004) conducted a field experiment on peach crop using developed automated drip fertigation system with different treatments. The experimental site layout was done using randomized block design and it consists of three treatments and four replications. The irrigation was done based sensor based automation and fertilizers were applied through automation by time based fertigation according pre-set time and the fertigation through automation compared with the traditional method of irrigation. Hence, the automated drip fertigation system proved that, the irrigation water was up to 40 per cent and fertilizer saving was 30 per cent compared to traditional irrigation.

Samsuri *et al.*, (2010) developed a nutrient solution mixing process on time-based drip fertigation system. The developed automated drip fertigation technique based on pre-set time applied the water and nutrients precisely at the root zone area of the plant and the pumping of irrigation water to field was done automatically, also pumping unit confirms the storage of water in the tank.

Mohd Salih *et al.*, (2012) introduced a cost effective automated fertigation system in green house for local farmers, which works with solar energy. The proposed fertigation system automatically applied nutrients to the root zone area of the crop according to crop requirements based on pre-set timings and the nutrient quality was observed at each fertigation interval using EC (electrical conductivity) meter. The developed system was easy to handle, portable and increased productivity.

Baljiti and Dilip (2013) introduced an automated nutrients composition control fertigation system. The developed system can monitor the EC and pH in the nutrient solution at each application; this will minimize the high salt concentration in the nutrients and pH content. The automated fertigation

technique can apply the nutrients efficiently according pre-set timings, this will improve the crop productivity and reduced soil pollution due to fertilizer saving.

The developed automatic fertigation system can efficiently balance the frequency of fertigation cycles based on plant transpiration and also maintain the electrical conductivity according to pre-set limits. Thus, developed fertigation system can reduce excess nutrient application more than crop requirement, which leads to fertilizer saving and reducing environmental issues such as minimizing soil and water pollution (Antonio *et al.*, 2014).

#### **2.4.6. GSM based automatic drip irrigation system**

Rahali *et al.*, (2011) developed a GSM based system for green house; by using GSM network the automated drip system can control examine any remote control system from any place in this world. The involvement of the GSM network in automated drip system enables us to build the green house more autonomous. Because the operator should attend the site for every irrigation and fertigation to switch ON and switch OFF the motor, this makes the operator more difficult to come and go from the field. So the remote control systems are more important in the advanced technologies to transfer the data to the user about field condition.

Purnima and Reddy (2012) developed automated drip irrigation system using GSM modem. The automated system is cost effective, simple in operation, portable and controlled through GSM modem and the module is interfaced with microcontroller unit. The drip system sends SMS to the concerned to the user about any unusual situations such as depletion of soil moisture content in the soil, increase in soil temperature and also CO<sub>2</sub> concentration. In future, the user can be able to monitor the entire system using GSM module and Bluetooth.

The increase or decreasing limits of the soil moisture content, status of temperature sensors can send to the GSM modem and water flow also controller by the user through SMS from user mobile device. Since the drip system was completely automatic so there by saving of irrigation water and labour. The

automated drip system consists of capacitor type soil moisture sensors to perform precise application of water to the plant according to crop water requirement. The system consists of Bluetooth for remote controlling which decreases the problem of signal ranging for GSM module. (Pavithra and Ranjith 2014).

The advantage of the GSM based irrigation system is the farmer can remotely control drip irrigation devices by using his mobile phone can be anywhere in the world. An automated system can improve the water use efficiency through precise application and reduced excess water consumption and increase in crop yield. The automated drip irrigation system can apply the water and nutrients to the crop root zone area precisely based on frequent intervals and irrigation scheduling. With proper design, installation, and management, drip irrigation systems can provide good and reliable performance in future (Danish *et al.*, 2016).

Arjun Prakash *et al.*, (2017) conducted a study on Hilton FI variety of salad cucumber by using GSM based drip irrigation system with different automation techniques. The automation consists of two conductive type and two capacitor type soil moisture probes. Crop growth parameters and crop yield showed best performance at 100 per cent fertigation when compared to 70% fertigation. Combination of 70% irrigation and 100% fertigation showed good results, but crop growth and yield were less in the case of 70% fertigation and 70% irrigation. The modified GSM based automated drip irrigation technique shows better performance and also cost effective, portable and durable.

#### **2.4.7. Wireless sensor networks**

Mahir and Semih (2011) designed and implemented a wireless data acquisition network to control the irrigation. The developed system allocates efficient maintenance of water sources and improvement in irrigation efficiency. The WSN irrigation system reduces water stress on crops and salt concentration at the root zone area. However the drip system was developed only for water application precisely, but the system can be modified into an automated drip



fertigation system to apply the water soluble fertilizer, pesticides and other chemicals precisely to the crop root zone according crop requirement. So the system is cost effective, reliable in nature and ecofriendly to the farmers.

Vandana *et al.*, (2011) stated that a Wireless sensor network (WSN) and Embedded based technique of DTMF (Dual Tone Multiple Frequency) were used in drip irrigation technique to control the water flow. The drip system based on WSN was more economical in case of water saving, power saving and saving in fertilizer. The developed drip irrigation system works with WSN and 'circuit switching' using GSM modem.

According to Giri and Wavhal (2013) by using linear programming the automated intelligent wireless drip irrigation technique provides to be a real time feedback control system which monitors all the activities of drip irrigation system efficiently as well as it helps us for to do the efficient water management in order to get good profit with less cost.

Gutierrez *et al.* (2013) suggested a system for automated drip irrigation based on GPRS modules and wireless sensor network. They calculate the moisture content and soil temperature and the data transferred to WSN using zigbee technology. The GPRS module also combined with WSN for transmitting the data to the web server. The system needs less maintenance and can be used for variety of crops. Additionally the module configuration adjusted for automated drip irrigation in large scale.

Majone (2013) introduced a WSN consist of 27 temperature sensors and 135 soil moisture probes, for an area of 5000 square metre in an apple orchard. The orchard is divided into three parts and different irrigation scheduling is applied to the each part. The five soil moisture sensors are equipped with each wireless sensor network and installed at the depths of 10, 20, 30, 50 and 80 cm, and a temperature sensor was installed at the depth of 20 cm. The developed system was associated to the interface by wireless platform for measuring real time data management, but the working of the system was unconventional to the

sensor nodes. The experiment shows that WSN hugely enables the collection of soil moisture data accurately and provides needful information for controlling hydrological processes.

## CHAPTER 3

### MATERIALS AND METHODS

Present study was mainly focused on development of an automated drip fertigation system with soil moisture sensors, GSM modem and solenoid valves. Field evaluation of the developed automated drip fertigation system was carried out under chilli crop in an open field located in KCAET, Tavanur. Comparative analyses of the biometric and yield observations were done in an open field with automated drip fertigation system and drip fertigation without automation.

#### 3.1. Study area

The experiment was conducted in an open field of ICAR Krishi Vigyan Kendra Malappuram, located at 10° 51'' 5' North Latitude and 75° 59'' 14' East Longitude. The area has humid sub-tropical climate with an average annual rainfall of 3000 mm, mainly from South – West and followed by the North - East monsoon. The experimental site consists of laterite soil. The meteorological parameters like temperature, relative humidity and light intensity were recorded from the experimental site.

#### 3.2. Automated drip fertigation system

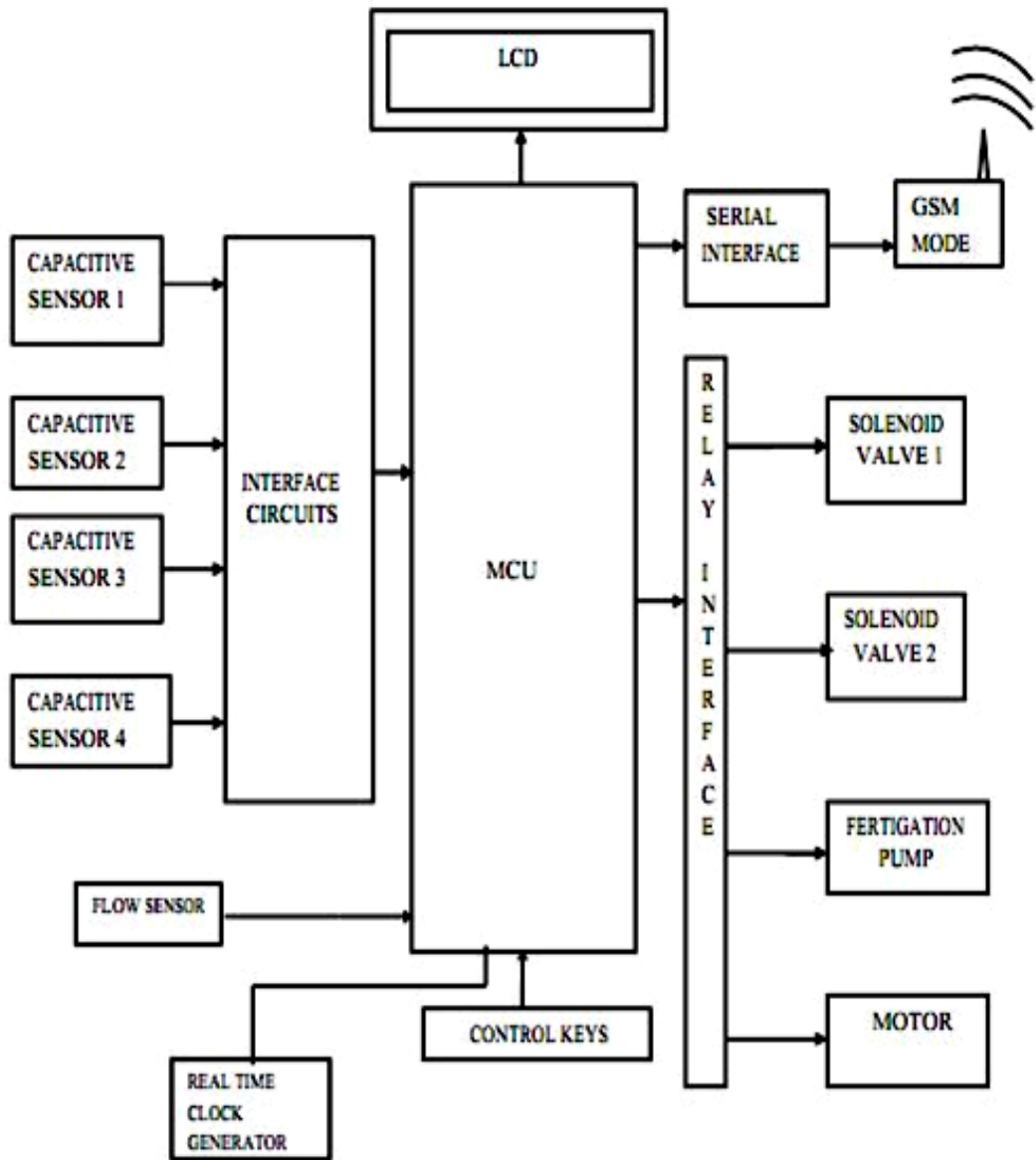
An automated drip fertigation unit for field use was developed in such way that to supply the required quantity of water and nutrients for the crop at any time. Automatic fertigation allows farmers to supply sufficient fertilizer in terms of quantity and concentration along with irrigation water to the root zone area of plant throughout the growth period automatically thereby saving labour, inputs, money and time. Automated drip fertigation reduces the wastage of water, decreases the chance of over or under fertigation and saves labour. It ensures accuracy in terms of dosage and time.

### **3.2.1. Components of the automation system**

Soil moisture is measured in terms of capacitance. The probes are designed in such a way that the capacitance sensors (or dielectric sensors) use capacitance to measure the dielectric permittivity of a surrounding medium. The automated drip fertigation system is designed with light weight, simple in operation and easy to handle. The sensors are calibrated and tested to use in the automated drip fertigation system. Fig. 1 shows the block diagram of the system.

The automation system consists of

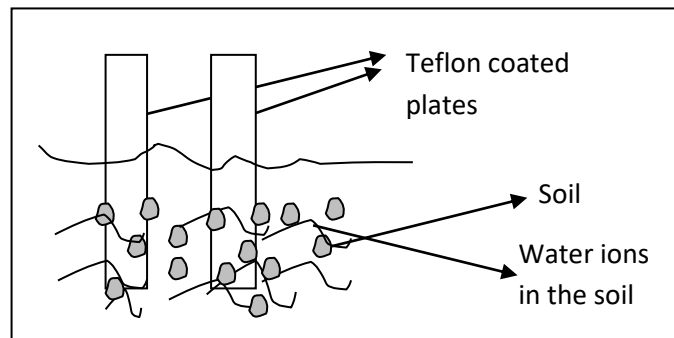
1. Capacitor type soil moisture sensors
2. Electronic control board (microcontroller unit)
3. LCD display
4. Pin description of LCD module
5. Control keys
6. Relay circuits
7. Centre tap transformer
8. IC voltage regulators
9. Power supply
10. GSM modem
11. Serial interface to GSM modem
12. Electronic fertilizer injection pump
13. Fertilizer mixing device
14. Solenoid valve



**Fig.1. Block diagram of automated drip fertigation system**

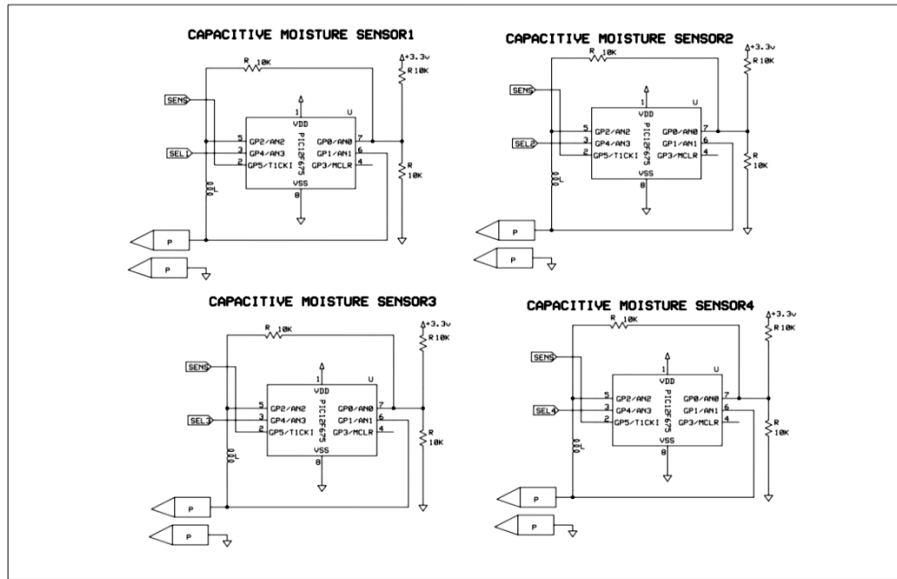
### 3.2.1.1. Capacitor type soil moisture sensor

A capacitance probe is a device, which incorporates an insulator that separates two electrodes. Capacitors are generally composed of a non-conducting substance that separates the two conducting plates which is called dielectric material. The capacitance sensors use the dielectric constant of an adjacent medium for determining the capacitance. Four capacitor type soil moisture sensors are fixed into the soil which measure soil moisture content in terms of variation in the ionic content of the soil medium. The measured values are transferred to the microcontroller, which shows the average values of each sensor in percentage. Plate 1 shows the capacitor type sensor and Fig. 2 shows the contact of probes with water ions.



**Fig. 2. Contact of probes with water ions**

The capacitance probe has high resolution and consumes less power. The probe is designed in such a way that capacitance between two parallel plates is covered with an insulator with high dielectric constant and strong material quality like 'Teflon'. When these plates are inserted into the soil, the plates act as a capacitor combined with the water ions in the soil and it is converted as capacitance. It is observed that this capacitance is directly related to the water ions present in the soil. If more water is present in soil, the corresponding capacitance will be more. The capacitance sensor output is connected to the microcontroller via interface circuit. Fig.3. shows the circuit of four capacitor type soil moisture sensors.



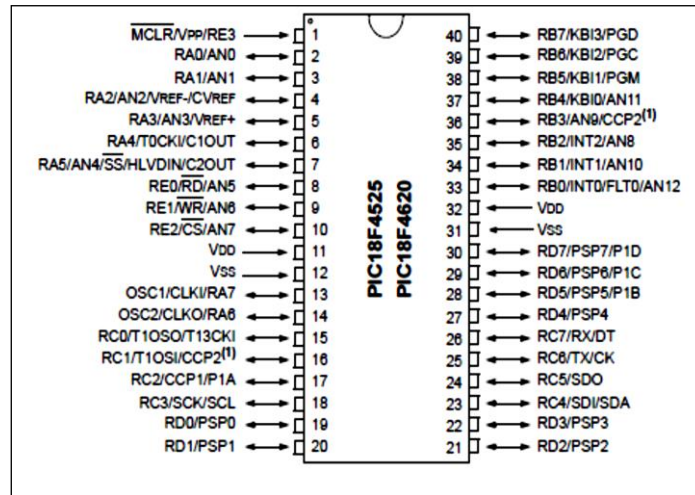
**Fig.3. Circuit of capacitor type soil moisture sensors**

### 3.2.1.2. Microcontroller unit

The PIC microcontroller PIC18F4620 was used for this study. The controller having built 13 channels ADC and UART with user selectable baud rate and also having built I2C module. PIC18F4620 is an 8BIT microcontroller with 64kb program memory and 4kb user data memory. These peripheral features and memory capacity made it our choice for this study. In this study popular 40 PIN DIP was used. The 40 pin package contains five I/O ports which can be programmed as either input or output. Fig .4 shows the pin diagram of microcontroller unit.

The microcontroller unit converts the data received from the soil moisture probes to digital form and transfer to the LCD display. A 1.5 HP motor and two solenoid valves were connected with the microcontroller unit through a relay circuit. When the received value from the sensor reaches the minimum pre-set moisture content value (permanent wilting point), the microcontroller unit will switch ON the motor automatically and send the SMS regarding the ON status of the irrigation system to the concerned user (mobile number which is saved in the SIM inserted in the GSM modem). Similarly, when the received value reaches up

to maximum preset value (field capacity), the microcontroller unit will switch OFF the motor and send the SMS regarding the status to the user. Plate 2 shows the microcontroller unit board.



**Fig.4. Pin diagram of microcontroller unit**

### 3.2.1.3. Liquid crystal display (HD 44780)

The HD 44780 is a “liquid crystal dot matrix display module” that consists of LCD panel, LCD control driver, a data RAM and ROM necessary to provide the display. This LCD is efficient to provide 16 characters x 2 lines display. Data interfacing is in 8-bit parallel or 4-bit parallel and also data can be written from a microprocessor. Plate 3 shows the LCD display and Fig. 5 shows the circuit of LCD module (HD 44780).

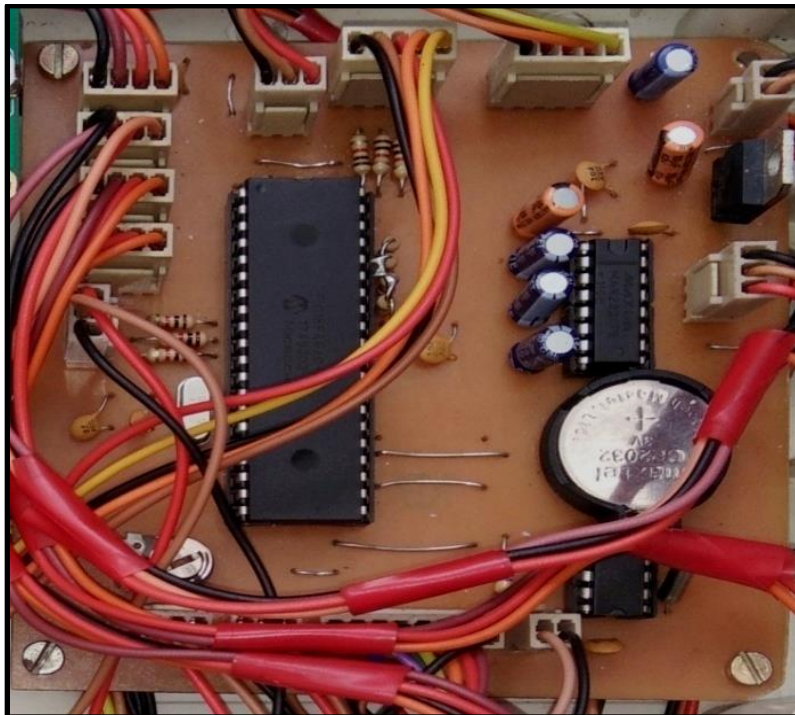
### 3.2.1.4. Pin description of LCD module

Liquid Crystal Display contains 16 pins, in which first three and 15<sup>th</sup> pins were used for power supply. The 4<sup>th</sup> pin is used as RS (Register Selection), its function is to display the command which is generated by microcontroller according to the status of the pre-set moisture content values. The 5<sup>th</sup> pin is R/W if it is low it performs write operation and the 6<sup>th</sup> pin is used for enabling the data. The remaining pins are act as data lines. Table1 shows the pin description of LCD module.

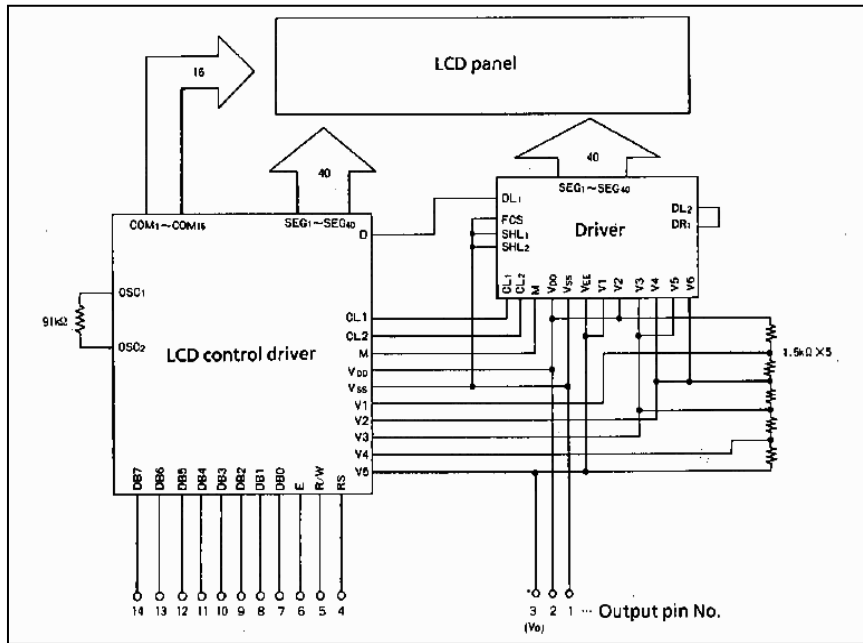




**Plate 1. Capacitor type soil moisture sensor**



**Plate 2. Board with microcontroller**



**Fig. 5 Circuit diagram of HD 44780 (LCD Module)**

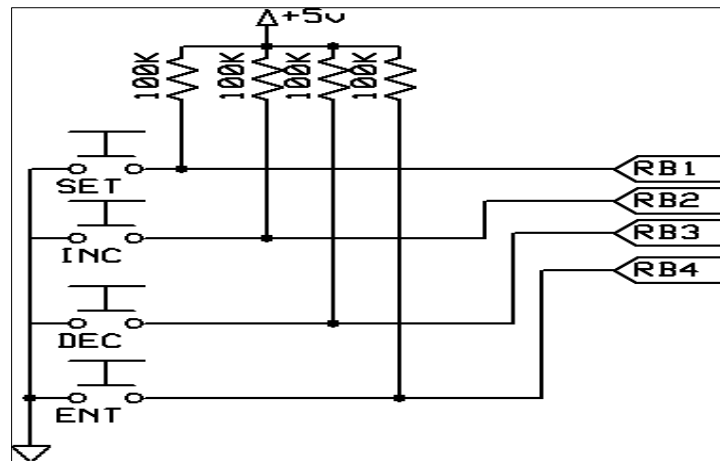
**Table1. Pin description of LCD module**

Pin	Symbol	I/O	Description
1	GND	-	Ground
2	Vcc	-	+5V power supply
3	VEE	-	Contrast control
4	RS	I	Command/data register selection
5	R/W	I	Write/read selection
6	E	I/O	Enable
7-14	DB0-DB7	I/O	The 8-bit data base

**3.2.1.5. Control keys**

The micro controller unit has NEXT OR EXIT, INC, DEC, SET UP, keys and these are connected to RB1, RB2, RB3, and RB4 of the MCU. Circuit connections of control keys are shown in Fig 6. These control keys are used to adjust the capacitance sensor values and the fertigation intervals. 200K resistor

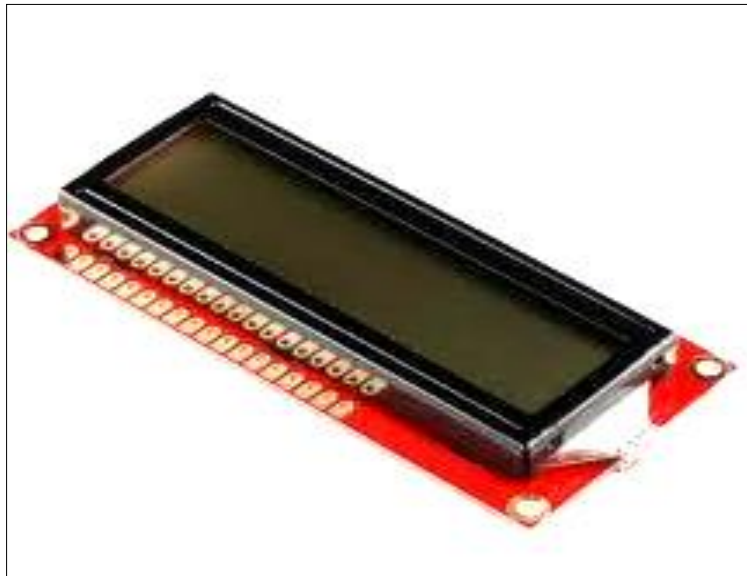
array is used to interface the control keys to the MCU. Among the four control keys (micro), two keys in the middle (INC and DEC) are used for increasing and decreasing the value of moisture content limits. The last key (SET UP) is used for adjusting the sensor data and fertigation timings. Plate 4 shows the arrangement of control keys below the display of microcontroller unit.



**Fig.6. Circuit of control keys**

### 3.2.1.6. Relay circuits

Electrical relays are interfaced to the MCU via the driving circuits. These relays are commonly used to control the power supply of home appliances, having inductive loads and are operated with voltage potential of 12V. MCU output has inefficient current to energize the relay. So it is fed to the Darlington pair array IC ULN2003, which is used for current amplification through interfacing. Output from this circuit is capable for driving the relay. Because of these reasons it requires interfacing circuits between these relays & MCU. In this system two such relays are used to control the devices.



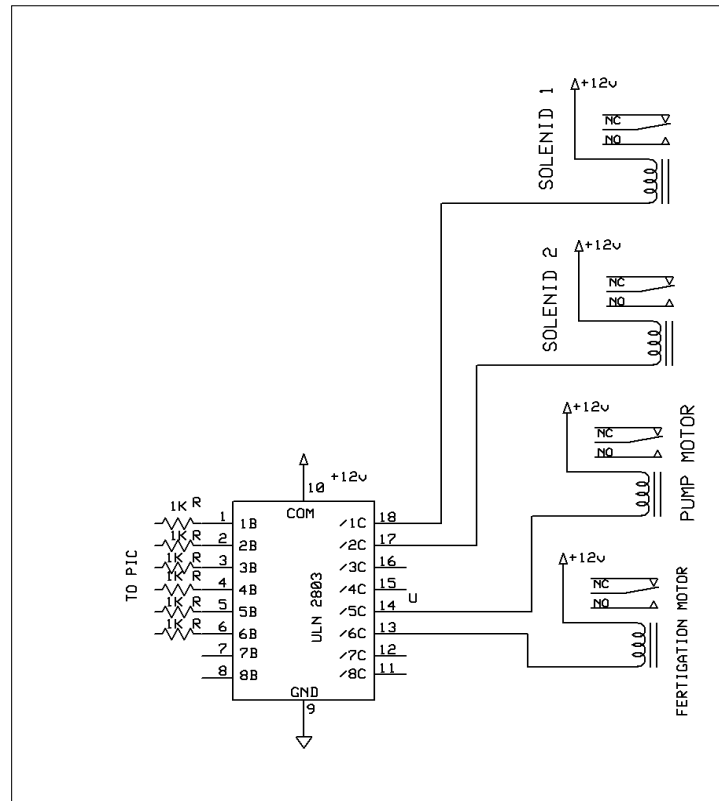
**Plate 3. Liquid crystal display**



**Plate 4. Control keys**

“Darlington pair is a compound structure consisting of two bipolar transistors connected in series (which means that the amplified current from the

first transistor is further amplified by the second transistor)”. This configuration gives a much higher current than from each transistor connected separately. Fig 7 shows circuit diagram of relay circuits.



**Fig.7. Circuit of relay circuits**

### 3.2.1.7. Centre tap transformer

“In electronic systems, a center tap is a contact made to a point half way along a winding of a transformer or inductor, or along the element of a resistor or a potentiometer”. Taps are sometimes used on inductors for the coupling of signals and may not necessarily be at the half-way point rather, closer to one end. 230V /12-0-12 transformer is used in the present system. Plate 5 shows the centre tap transformer

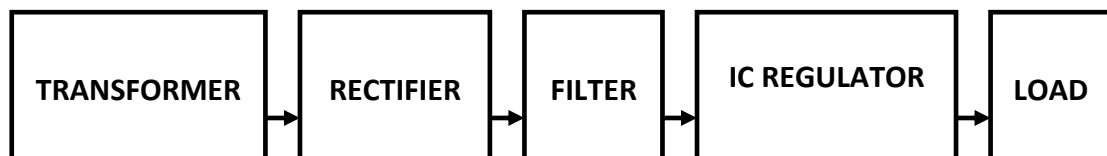
### 3.2.1.8. IC voltage regulators

The power supply is the most indispensable part of any system. IC regulators are versatile and relatively inexpensive. The regulated circuit is used to maintain constant output level. The integrated circuit regulator, some time called the three terminal regulators contains the circuitry of reference source error amplitude control device and overloaded protection all in a single IC chip. They are connected between output of the filter and input of the load. The 78xx series consist of three terminal +ve voltage regulators. With adequate heat sinking they can deliver output current in excess of 1A. For proper operation, there should be a common ground between the input and output voltages. The series 78 regulators provide fixed positive regulated voltages from 5 to 24 volts. Similarly, the series 79 regulators provide fixed negative regulated voltages from 5 to 24 volts. Plate 6 shows the pin arrangement of IC voltage regulator.

### 3.2.1.9. Power supply

The Ac voltage, typically 220V rms, is connected to a transformer, which steps that Ac voltage down to the level of the desired Dc output. A diode rectifier provides a full-wave rectified voltage which is initially filtered by a simple capacitor filter to produce a Dc voltage. This resulting Dc voltage usually has some ripples or voltage variation.

A regulator circuit removes the ripples and also remains the same Dc value even if the input Dc voltage varies, or the load connected to the output Dc voltage changes. This voltage regulation is usually obtained using one of the popular voltage regulator IC units. Fig 8 shows the block diagram of power supply.



**Fig.8. Block diagram (power supply)**

### 3.2.1.10. GSM modem

The working of a GSM modem is mainly based on SIMCOM technology. The modem Quad Band is GSM/GPRS 850/900/1800/1900 which is MHzGPRS multi-slot class and 10/8 GPRS Mobile station class B. This modem can operate at a temperature of (-20° C to +55° C) and having power consumption in normal operation is 250ma, can rise up to 1Amp while transmission. Plate 7 shows the GSM modem connection inserted with SIM and Fig. 9 shows the circuit diagram of GSM modem.

### 3.2.1.11. Serial interface to GSM modem

MAX232 IC is used to interface the microcontroller with GSM modem. The 11<sup>th</sup> pin of the MAX232 IC is connected to the serial port TX of the microcontroller i.e. to pin RC6. RS232 connectors are used to connect the MAX232 output to the MODEM serial port. Fig 10 shows the circuit connection of serial interface to GSM modem.

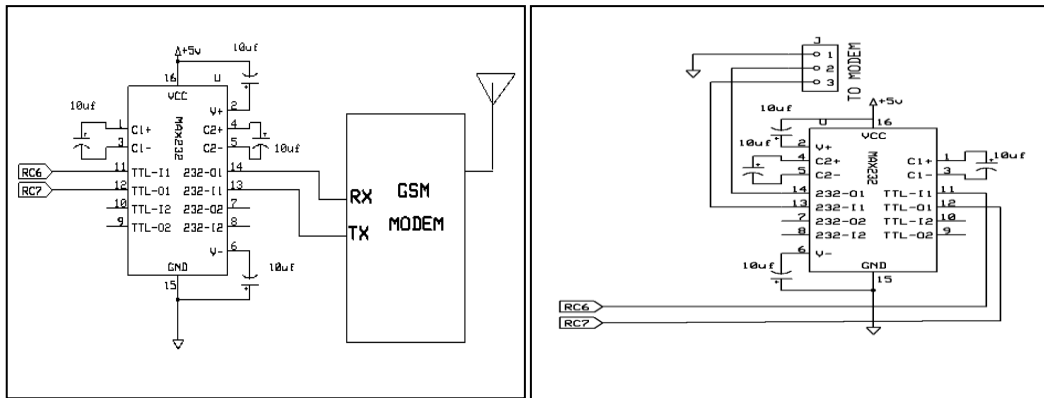
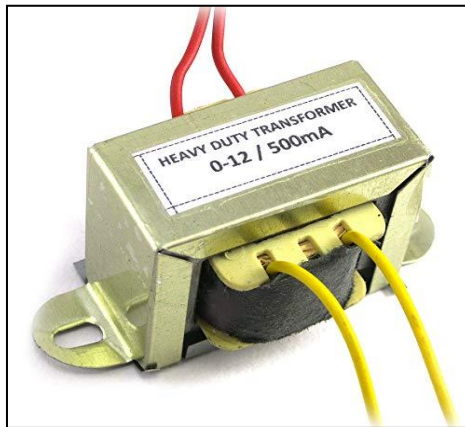
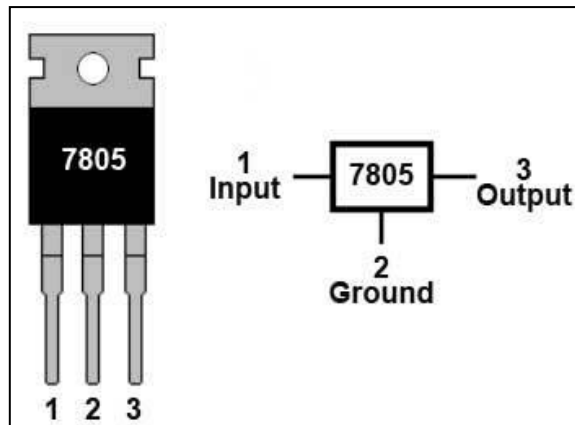


Fig.9. Circuit of GSM modems

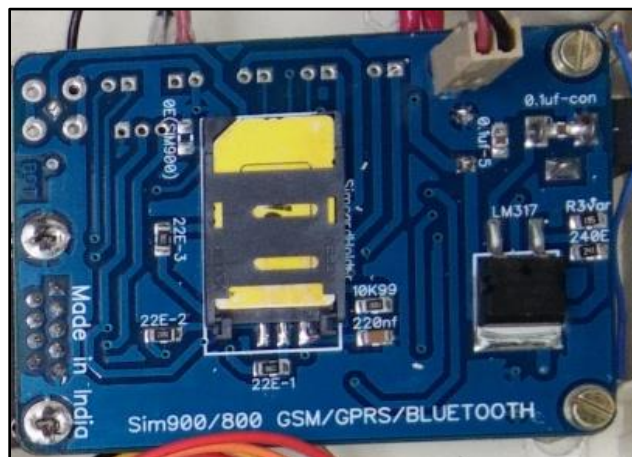
Fig.10. Circuit of serial interface to  
GSM modem



**Plate 5. Centre tap transformer**



**Plate 6. IC voltage regulator**



**Plate 7. GSM modem connection**



### **3.2.1.12 Electronic fertilizer injection pump**

The electronic fertilizer injection pump (trade name is e-dose manufactured by Initiative Engineering) is innovative compact design and is operated with electricity. In this pump additional fine suction filter is provided to avoid entry of solid particles in the system. The pump gives accurate and proportional injection rate, and having special adjusting lock arrangement. Fertilizer application rates were 1.5; 3.0; 6.0 & 10.0 lph at a pressure of 4 kg/cm<sup>2</sup>. The injection pump is 230 V AC, 50 Hz and power consumption at 400 rpm 30 W. The time interval and duration of fertilizer application can be pre-set in the microcontroller. The pump is connected to the microcontroller and it works automatically according to preset timings set with the microcontroller. The water soluble fertilizers were applied through this pump according to the pre-set value of fertilizer scheduling of chilli crop. Plate 8 shows the installed electronic fertilizer injection pump to the mainline.

### **3.2.1.13. Fertilizer mixing device**

Based on fertigation schedule of the chilli crop, the water soluble fertilizers were taken in a closed container to maintain the concentration of the fertilizers. The fertilizers are water soluble but which can settle at the bottom of the container after some time and this will reduce the efficiency of the fertigation, which leads to the lack of nutrients to the crop and poor crop performance. So an electronic mixing device was installed along with the fertigation system and it was connected with the microcontroller. When the fertigation process carried out, the mixing device switches ON automatically and mixes the nutrients thoroughly through agitation process. Plate 9 shows the fertilizer mixing device with fertilizer storing container.



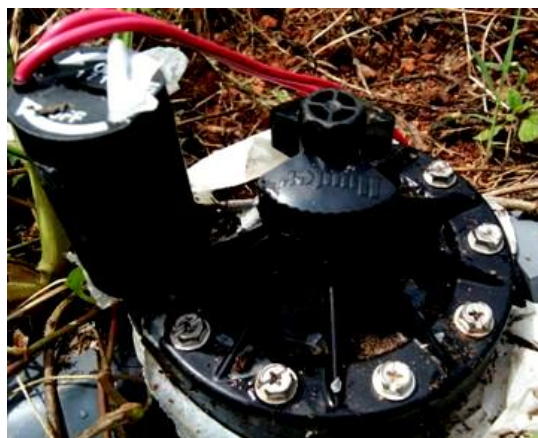
**Plate 8. Electronic fertilizer injection pump**



**Plate 9. Electronic fertilizer mixing device**

### 3.2.1.14. Solenoid valve

A solenoid valve is an electrochemical device used for controlling liquid or gas flow. The solenoid valve is controlled by electrical current, which is run through a coil. When the coil is energized, a magnetic field is created, causing a plunger inside the coil to move. Depending upon the design of the valve, the plunger can either open or close the valve. When electrical current is removed from the coil, the valve returns to its initial state. Two such solenoid valves of 1.5” diameter of Hunter Company are used in this study to regulate the flow of irrigation. These valves will work according to the soil moisture content in the soil received by the microcontroller from the sensors installed in the field. Plate 10 shows the arrangement of solenoid valve on the main pipe line.



**Plate 10. Arrangement of solenoid valves in main pipe**

### **3.3. Design of automated drip fertigation unit**

The drip fertigation system is fabricated and designed with cost effective materials and chips with the consideration of corrosiveness, ease of handling, sensitivity to physical parameters, ease of installation, quick response and durability etc. The drip fertigation system is combined with microcontroller, which collects the reading from the capacitor type sensors. The four capacitor type sensors give quick response to the moisture content.

Capacitor type sensor, which senses the capacitance of soil and calculate the volumetric moisture content and has a long leg of around 100 mm length and 30mm width made up of Teflon material. The system contains sim900 GSM modem used for sending and receiving output data and input commands respectively. A macro SIM was inserted in to the modem for the operation of the drip fertigation system. The LCD screen used to display the sensor readings, average of four sensors, fertigation timings and the present status of the motor. Control keys are arranged below the display section to adjust upper and lower limits of the sensor values and fertigation timings.

The sensors are installed in the field and connected to the microcontroller unit. When the moisture content which sense by the sensor goes down the pre-set value of lower limit, then the microcontroller switches ON the motor automatically and sent the SMS to the concerned number about the motor status.

The water soluble fertilizers were applied through this fertigation injection pump according to the pre-set value of fertilizer scheduling of chilli crop in the microcontroller unit. When the fertigation process carried out, the mixing device will switch ON automatically and mix the nutrients thoroughly through agitation process. Two solenoid valves were installed on the mainline, which regulated the flow of water to the field for different treatments. The design of automated drip fertigation system is shown in a block diagram in Fig.1.

### 3.3.1 Calibration of soil moisture sensor

For proper working of the systems, the sensors were calibrated in the laboratory before field installation. Calibration was carried out for three well defined soil types viz. laterite soil, black soil and coastal alluvium soil. For the calibration process, three well dried soil samples of each soil types weighed 700 g were taken in three containers and added 10, 20 and 30 per cent of moisture to the 1, 2 and 3 containers respectively. The containers were kept for 24 hours by covering with lid and the moisture content was measured after 24 hours with capacitance probe. 1, 2 and 3 containers were showed 9, 18 and 29 per cent moisture content respectively. From this process, it could be observed that the capacitance probe performed well and showed the good results. Calibration process was carried out for each sensor for the three soil types and moisture contents and the average values were observed. Plate 11 shows the calibration of capacitance sensors in the laboratory.

### 3.3.2. Maintenance

System can operate effectively and efficiently by proper planning and maintenance. The important steps for proper operations of the system are given below.

- Ensure that the system is fully covered for the prevention of water and check all the parts of system are connected into the board securely.
- The sensor terminals such as positive and negative are connected properly into the ports provided in the system.
- Ensure the GSM modem is connected correctly and the modem turns ON/OFF properly.
- Insert the sensors into the soil accurately to avoid gap between the soil moisture sensor and bed of soil.
- The ON/OFF terminals of the motor interface and relay should connect properly to the system and the motor.
- The transformer having 240V direct current, care should be taken to avoid

contact with the transformer.

- The proper maintenance is needed for the fertigation pump, because sometimes air will enter in the pipe so it will decrease the efficiency of the pump. Air should be removed regularly.
- The fertilizer tank should be air tight due to remain the concentration of the fertilizers.

### **3.4. Field experiments using automated drip fertigation system**

The automated drip fertigation system was designed and fabricated at the research workshop and calibration experiments for soil moisture sensors were done in the soil and water conservation engineering laboratory of KCAET, Tavanur, Malappuram. Field experiments were carried out in the open field of KVK, Malappuram during the period of February to June 2019.

#### **3.4.1. Crop and variety**

The KAU chilli variety 'Ujwala' - CA 219-1-19-6 (*Capsicum annum*), was raised for the field experiment. The crop has 120 days duration and it is good variety with high productivity bacterial wilt resistant, resistant to mosaic and leaf roller attack. Required chilli seedlings were prepared in the nursery by sowing seeds before one month of transplantation to the field with utmost care to reduce the virus attack (Plate 12).

#### **3.4.2. Soil moisture constant**

Soil moisture constants such as field capacity, permanent wilting point and available moisture were determined using pressure plate apparatus in the laboratory. Soil samples were collected from the experimental site at 15 cm depth from different locations. The air dried sample was sieved through 2 mm sieve and filled in to the rings of apparatus kept on ceramic plates having pressures rating of 1 bar and 15 bar. The plates with soil samples were saturated for 24 hours by immersing in a container. The saturated plates were kept in the pressure chambers for 24 hours at 0.3 bar (field capacity) and 15 bar (permanent wilting point). After

48 hours the two different soil samples (0.3 bar and 15 bar) were carefully taken out from the chambers and transferred to the moisture boxes. The samples were then weighed and placed in an oven for 24 hours. The field capacity and permanent wilting point were calculated based on wet weight and dry weight of the soil sample. Available moisture was noted as FC - PWP. Plate. 16, 17 and 18 shows the pressure plate apparatus experiment.

### **3.4.3. Field preparation**

An open area of 200 m<sup>2</sup> was selected in the KVK premises for the field performance evaluation of the automatic drip fertigation system. The field was ploughed thoroughly and the leveled for making beds. For the field experiment, nine beds were prepared with 90 cm width and 15 cm height at a spacing of 80 cm (Plate 13). Fumigants were applied to the prepared bed 10 days before the planting for controlling soil-borne diseases and weeds. Basal dose of fertilizer and organic manure were applied to the soil bed. In order to avoid the weed growth and evaporation, plastic mulching film (30 gauge) was laid on the beds and holes were made for planting one month old seedlings at a spacing of 60 cm (Plate 14).

### **3.4.4. Field Layout of drip system**

For the experimental purpose, out of nine beds, three beds each were selected for three treatments which are explained below. Fig. 11 shows field layout with treatments and replications of the present study.

- T1-100 percent fertigation and 100 percent irrigation (with automated drip fertigation)
- T2-100 percent fertigation and 100 percent irrigation (without automation)
- T3-100 percent irrigation and 70 percent fertigation (with automated drip fertigation)

For the statistical analysis of this experimental study, six replications for each treatment were taken and design of field layout is fixed according to CRBD.

#### **3.4.5. Layout of irrigation and fertigation system**

The water was pumped from the tank of 1000 litre using 1.5 hp motor and a 60 mm PVC pipe was used as main line of the drip irrigation system. A hydrocyclone filter and a screen filter were installed before and after the fertigation system in the main line to prevent all fine particles entering the irrigation water. Two lines of 16 mm inline laterals lines of 60 mm emitter spacing were laid on each bed at a spacing of 60 cm. Inline laterals were laid out in such a way that each dripper is located in the centre of the hole already made in the plastic mulching film where the seedlings to be planted. Water from the main line gets split into two directions using T connector and each section was connected with a solenoid valve to regulate the water for the treatment with automation (T1 and T3) and directly flowing to laterals for the treatment without automation (T2) as shown in Fig. 11. Seedlings prepared in the nursery were transplanted to the hole already prepared in the mulching film at a spacing of 60 cm (Plate 15).



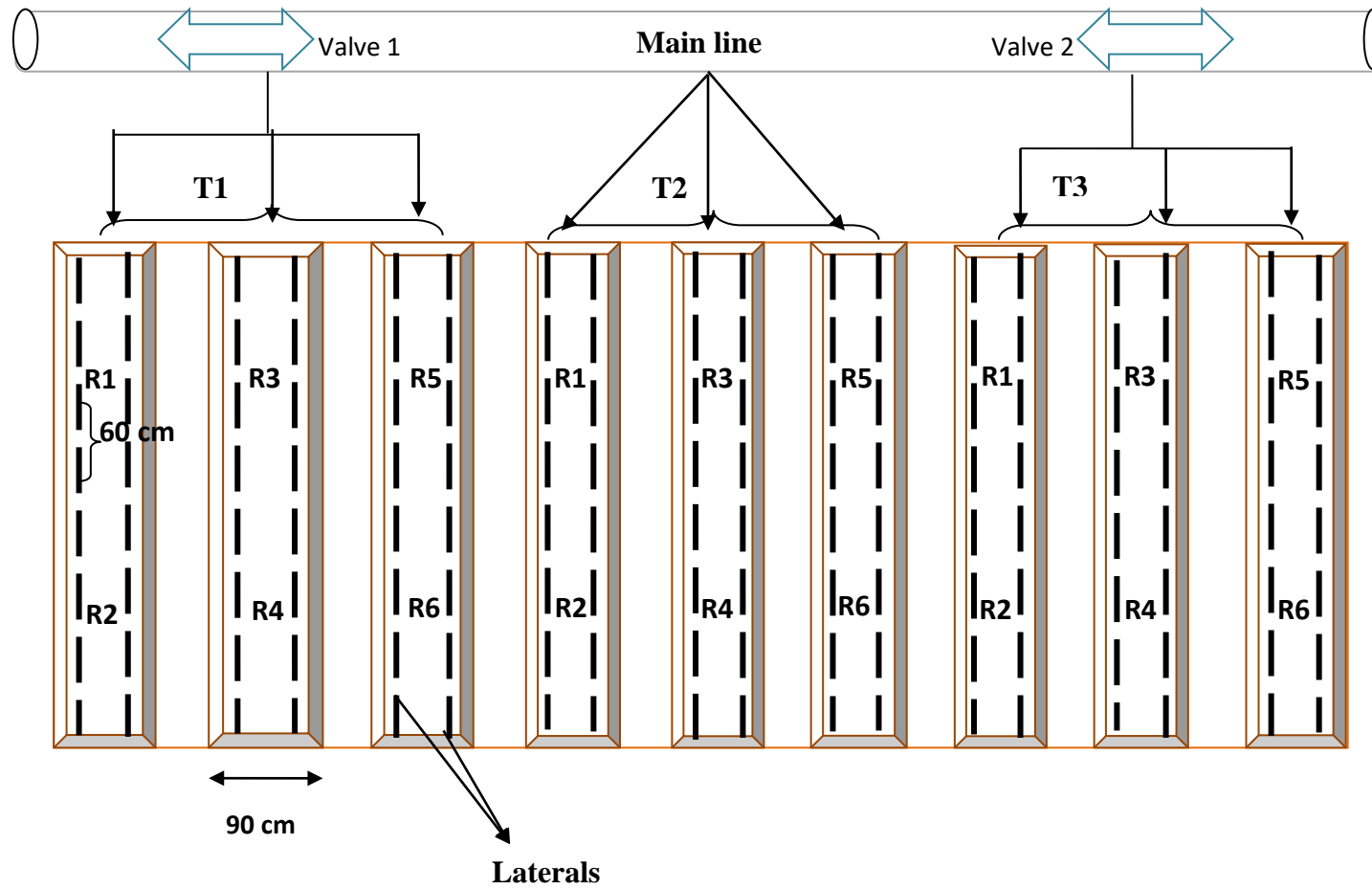


Fig 11. Field layout



**Plate 11. Calibration of capacitance sensor with different moisture contents**



**Plate 12. Chilli in nursery**



**Plate 13. Field preparation**



**Plate 14. Beds covered with mulch**



**Plate 15. Planted condition of chilli**



**Plate 16. Pressure plate apparatus**



**Plate 17. Ceramic Plate (15 bar)**



**Plate 18. Ceramic plate (1 bar)**

### 3.4.6. Fertigation treatments

Recommended fertilizers for Ujwala variety of chilli crop were applied at three days interval. 19:19:19, Potassium Nitrate (13:0:45) and urea were used as the source of NPK. Fertigation treatments in each bed are given in Table 2.

**Table 2. Fertigation treatments**

<b>Days of fertigation</b>	<b>Water soluble fertilizer</b>	<b>T1 – 100% Fertigation (Kg) (With automated drip fertigation)</b>	<b>T2 – 100% Fertigation (Kg) (Without automation)</b>	<b>T3 – 70% Fertigation With automation(Kg)</b>
	Basal dose P	1.300	1.300	0.910
3-36	19:19:19	0.170	0.170	0.119
	13:00:45	0.010	0.010	0.007
	Urea	0.175	0.175	0.122
	12:61:00	0.000	0.000	0.000
39-120	19:19:19	0.090	0.090	0.063
	13:00:45	0.300	0.300	0.210
	Urea	0.090	0.090	0.063
	12:61:00	1.300	1.300	0.910

### **3.5 Field data collection**

#### **3.5.1 Biometric observations**

The important crop growth parameters such as plant height, number of leaves and stem girth were observed. Chilli seedlings were transplanted on 15/02/2019. Eighteen plants randomly were selected from each plot for biometric observations.

##### **3.5.1.1 Height of the plant**

Plant height of the chilli crop was measured for the randomly selected crops for all treatments and replications at 15, 30, 50 and 80 days after transplanting (DAP).

##### **3.5.1.2 Number of leaves of the plants**

The number of leaves per plants were counted for the randomly selected crops for all treatments and replications at 15, 30, 50 and 80 days after transplanting (DAP).

##### **3.5.1.2 Stem girth**

The stem girth was measured at height of 15 cm above the ground, for the randomly selected crops for all treatments and replications at 15, 30, 50 and 80 days after transplanting (DAP).

#### **3.5.2. Yield parameters**

Yield parameters such as fruit size and number of fruits per plant from randomly selected plants of all treatments and replications were noted. The yield per plant were noted during the crop period and the average yield was worked out for each treatments in tones per hectare (t/ha).

## CHAPTER 4

### RESULTS AND DISCUSSIONS

This study focused on the development of GSM based automated drip fertigation system coupled with sensor based irrigation and time based fertigation automation for better irrigation efficiencies. Calibration of capacitive sensors under different soil moistures and for different types of soils were carried out in the Soil and Water Engineering Laboratory, KCAET, Tavanur. Field evaluation of automated drip fertigation system was conducted in the open field by using Ujwala (KAU) variety of chilli crop. Results of the calibration of sensors and field evaluation are discussed in detail in this chapter.

#### 4.1. Particle size analysis

Three well defined soil types were collected from three different locations for doing the particle size analysis, viz. laterite soil, coastal alluvium and black soil. Particle size distribution was found out using sieve analysis and sedimentation analysis.

##### 4.1.1. Sieve analysis

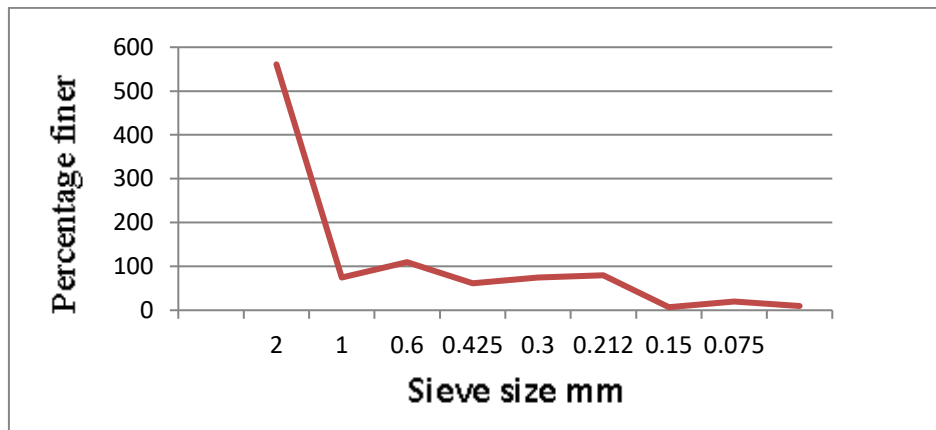
For the sieve analysis sieves of 2 mm, 1 mm, 600  $\mu\text{m}$ , 425  $\mu\text{m}$ , 300  $\mu\text{m}$ , 212  $\mu\text{m}$ , 150  $\mu\text{m}$ , and 75  $\mu\text{m}$  size sieves were arranged one below the other. The air dried soil sample of 1 kg was placed in the top sieve and the sieving was done up to 10 min. The soil samples retained on each sieve after sieving were collected and weighed. The percentage of sample retained on each sieve was calculated and the particle size distribution curve was drawn. The particle distribution curves of all three soil types such as laterite soil, black soil and coastal alluvium soil are shown Fig.12, 13 and 14 and tables given in Appendix I.

##### 4.1.2. Sedimentation analysis (hydrometer method)

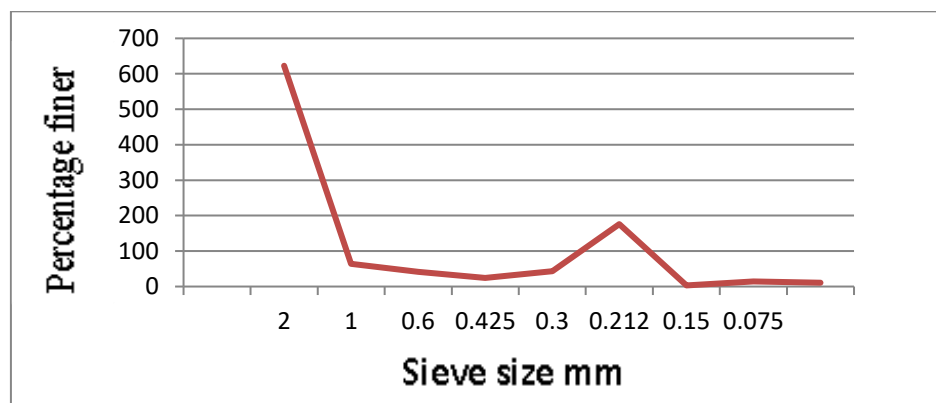
About 50 g of soil samples finer than 75  $\mu\text{m}$  were taken into a 1000 ml measuring jar and mixed with distilled water. This solution was tested using

hydrometer. The readings at different intervals were noted and particle distribution curves were drawn for laterite soil, black soil and coastal alluvium. The calibration curves are shown in Fig. 15, 16 and 17 and the calculation part is given in Appendix II.

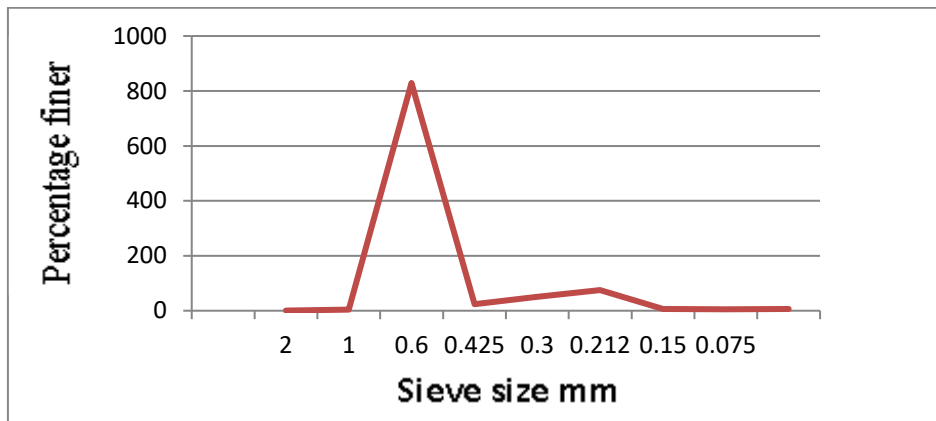
From the particle size distribution curves, it could be observed that the texture of laterite soil is sandy loam and that of black soil is clayey loam. The Coastal alluvium soil showed linear increase but the finer percentage was very less as compared to the other soils.



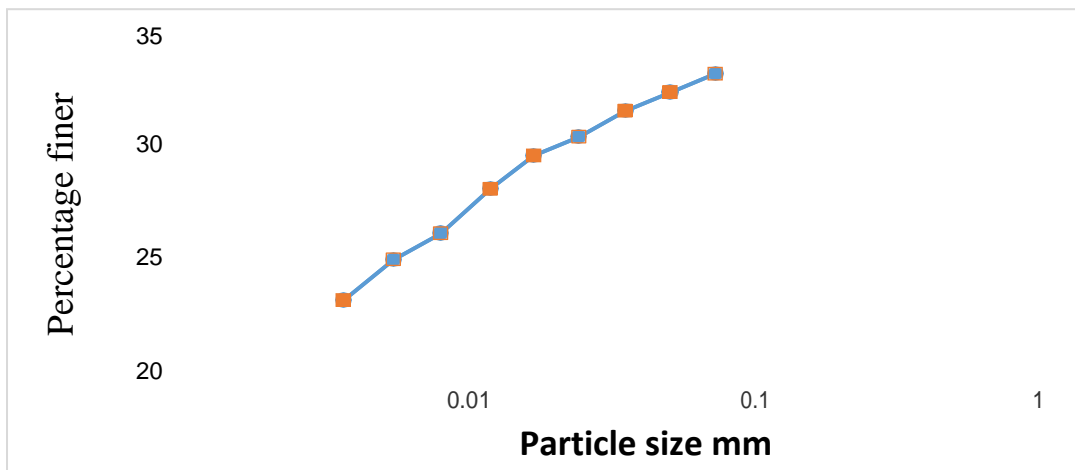
**Fig. 12 Sieve analysis of Laterite soil**



**Fig. 13 Sieve analysis of black soil**

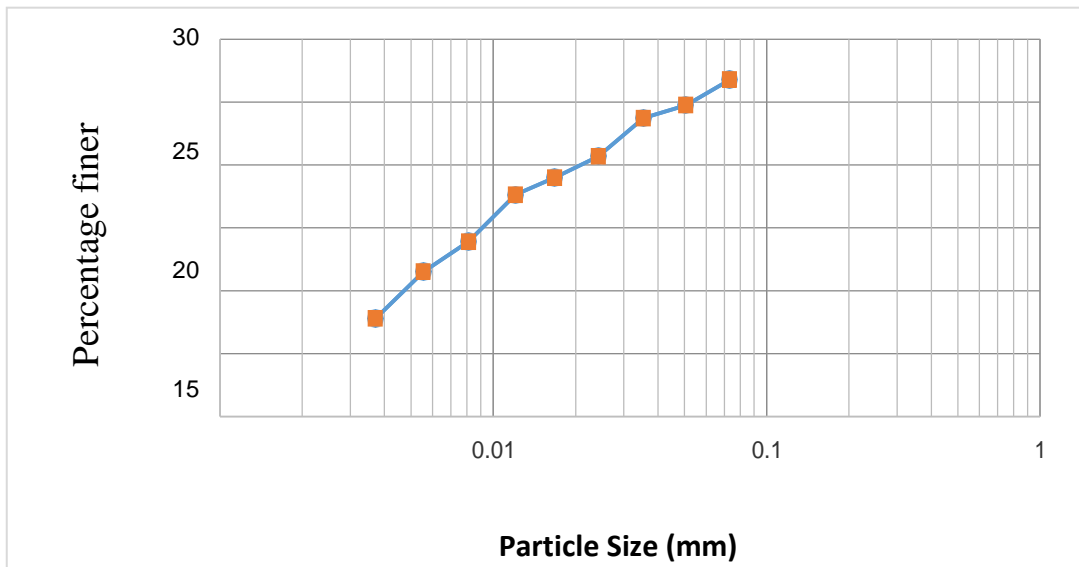


**Fig. 14 Sieve analysis of coastal alluvium soil**

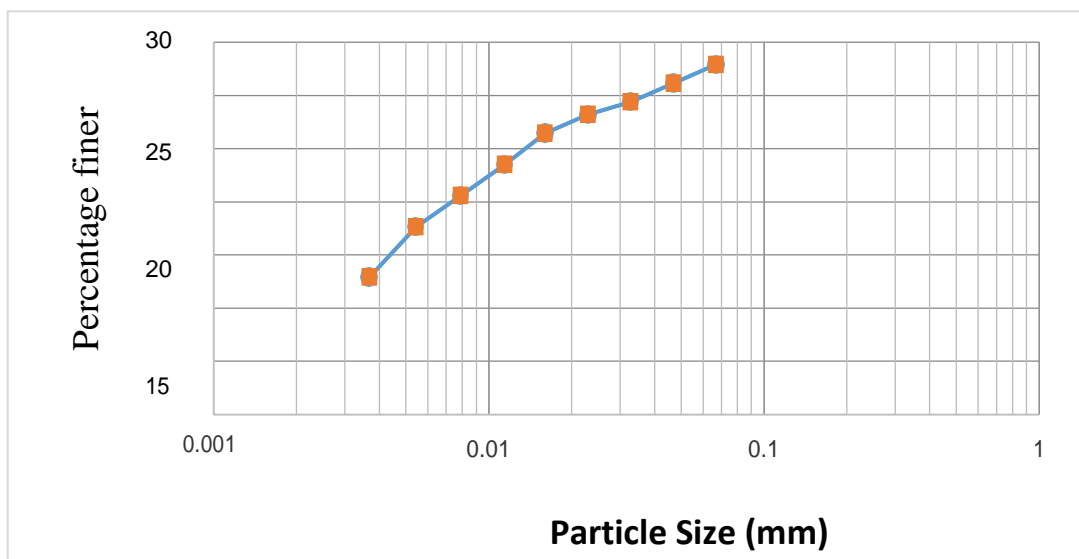


**Fig. 15 Particle size distribution curve of laterite soil**





**Fig. 16 Particle size distribution curve of black soil**



**Fig. 17 Particle size distribution curve of coastal soil**

#### 4.2. Calibration of sensors in different soils

Calibration of capacitance sensors was carried out using three different types of soils collected from different locations. Soil moisture content measured using gravimetric method and corresponding capacitance values of each sensor were noted during 5 days continuously. The soil moisture content and corresponding average of four sensor capacitance values for 3 different types of soils are given in Table 3. The capacitance values for individual soil are given in Table 4, 5 and 6. Calibration curves plotted with capacitance value (F) against soil moisture content (%) of three types of soils are shown in Fig18, 19 and 20.

**Table 3. Calibration values of capacitance soil moisture sensor**

Soil type	Weight of the dried soil (gm)	Water added to the soil (%)	Weight of water added (g)	Avg reading by sensor after 24 hours (%)
Laterite soil	700	10	70g	8
		20	140g	18
		30	210g	29
Black soil	700	10	70g	8
		20	140g	19
		30	210g	27
Coastal alluvium	700	10	70g	9
		20	140g	17
		30	210g	28

**Table 4. Calibration data of capacitor sensors in laterite soil**

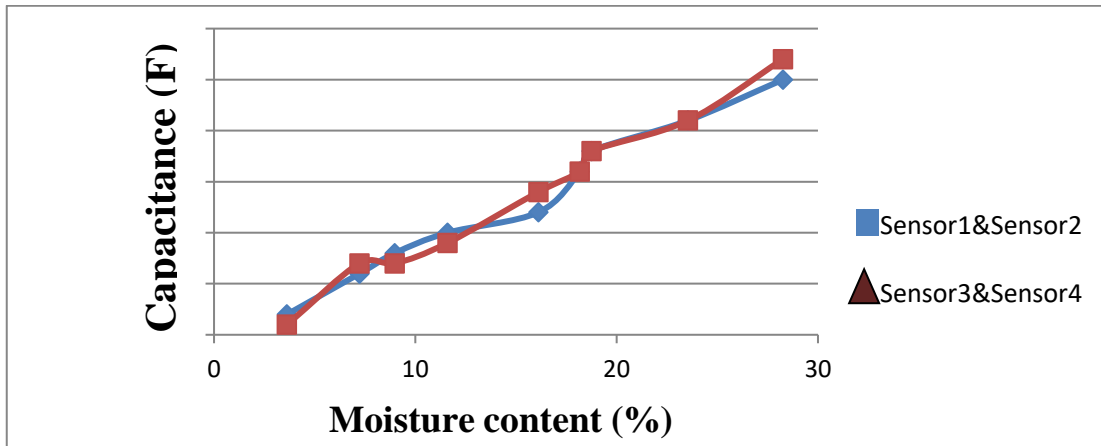
Days	Moisture content (%)			Capacitance (F)					
				Average of capacitor sensor 1 &2			Average of capacitor sensor 3 & 4		
	10	20	30	10	20	30	10	20	30
1	6.08	18.1	25.90	6	16	24	5	18	22
2	4.30	16.0	21.01	4	14	19	4	13	20
3	2.10	11.2	16.25	1	8	13	2	9	13

**Table 5. Calibration data of capacitor sensors in black soil**

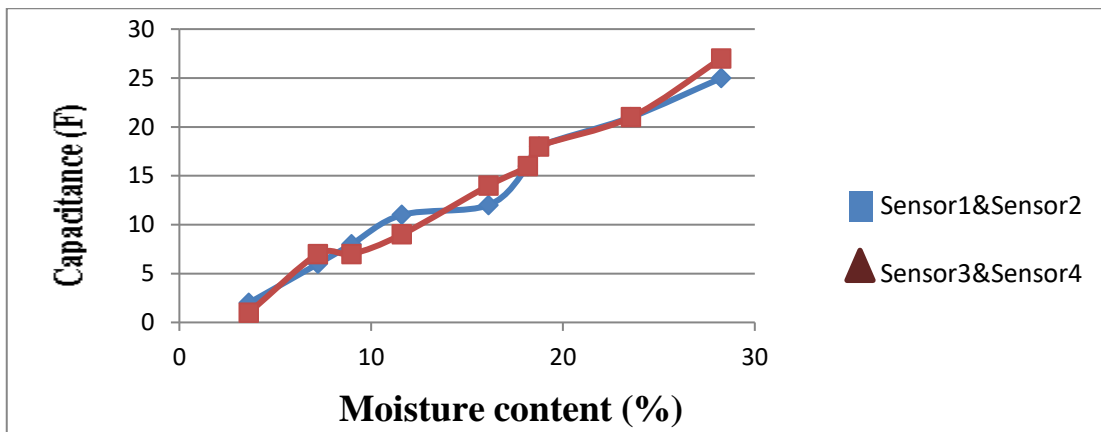
Days	Moisture content (%)			Capacitance (F)					
				Average of capacitor sensor 1 &2			Average of capacitor sensor 3 & 4		
	10	20	30	10	20	30	10	20	30
1	8.98	18.8	28.26	8	16	26	7	18	27
2	7.23	16.1	23.55	6	12	21	7	14	21
3	3.63	11.6	18.17	2	10	18	1	9	16

**Table 6. Calibration data of capacitor sensors in coastal alluvium soil**

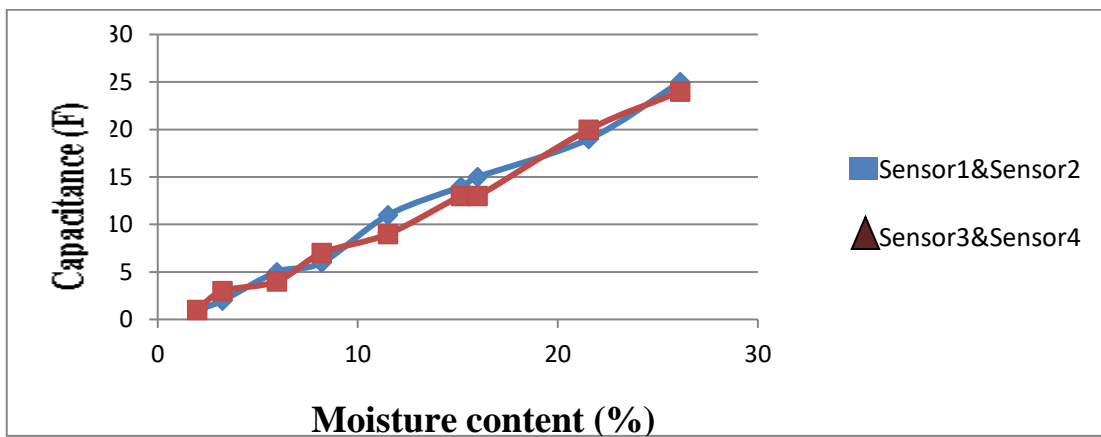
Days	Moisture content (%)			Capacitance (F)					
				Average of capacitor sensor 1 &2			Average of capacitor sensor 3 & 4		
	10	20	30	10	20	30	10	20	30
1	5.96	16.0	26.13	5	14	22	4	13	24
2	3.25	11.5	21.55	2	11	19	3	9	20
3	1.98	8.21	15.17	1	6	15	1	7	13



**Fig. 18.** Calibration curve of capacitance sensors in laterite soil



**Fig. 19.** Calibration curves of capacitance sensors in black soil



**Fig. 20.** Calibration curves of capacitance sensors in coastal alluvium soil

The variation in the value of capacitance (F) of different soil samples is due to the dielectric property. The capacitance value of sensor decreases slowly with the reduction of soil moisture content. The maximum and minimum capacitance values of laterite soil was 24 F and 1F corresponding to moisture content of 25.9 and 2.1 percent respectively. The capacitance values of black soil were 26 F and 2F corresponding to moisture content of 28.6 and 3.63 % and in coastal alluvium it was 22F and 1F corresponding to moisture content of 26.13 and 1.98 % respectively.

Laterite soil exhibits a linear relationship of soil moisture content and capacitance value of the probe. Black soil showed non-uniform variation in the sensor capacitance value when the soil moisture content reduced below the field capacity. In case of coastal alluvium soil, the capacitance value reduced slowly after the field capacity. Results showed that from the saturated condition to field capacity of the soil, sensor capacitance value decline slightly and after that even small reduction in soil moisture content, the capacitance probe showed large variation.

#### **4.3. Determination of soil moisture constants**

The measured soil moisture content at 0.3 bar and 15 bar, corresponding to the field capacity and permanent wilting point were used to fix the pre-set values in the micro controller unit for the capacitance sensor to operate the system. The soil type is laterite and the field capacity and permanent wilting point values were 14.82 and 7.6 percent by gravimetric basis. The values of field capacity and permanent wilting were mentioned in the Table 7.

The Management Allowable Deficit (MAD) criteria fixed for scheduling the irrigation was 50 per cent. That means when 50 per cent of the available moisture is depleted, irrigation is to be given. In the present study the available moisture content (difference between field capacity and permanent wilting point) was 10.51% (volumetric basis) and hence when the soil moisture content is reduced by 5.2%, the system switches ON the motor automatically to start the

irrigation. The system will switch OFF the motor automatically when the soil moisture content reaches the field capacity (21.6%).

**Table 7. Values of field capacity and permanent wilting point (gravimetric basis)**

<b>Field capacity % (0.3 bar)</b>	<b>Permanent wilting point % (15 bar)</b>	<b>Available moisture % (FC-PWP)</b>
14.82	7.6	7.22

#### **4.4. Performance evaluation of GSM based automated drip fertigation system**

The fabricated automated drip fertigation system consists of cost effective materials and chips based on the consideration of corrosiveness, ease of handling, sensitivity to physical parameters, ease of installation, quick response, durability etc. Drip fertigation system is combined with micro controller, which receives the reading from the capacitor type sensors. Capacitor type sensors sense the capacitance of soil accurately and calculate the volumetric soil moisture content. Evaluation of capacitance sensor is shown in Plate 19. The system contains sim900 GSM modem used for sending and receiving output data and input commands respectively. A macro SIM was inserted in to the modem for the operation of the drip fertigation system.

Water soluble fertilizers were applied through the fertigation injection system based on the pre-set values of fertilizer scheduling for chilli crop in the micro controller unit. When the fertigation process is carried out, the mixing device will switch ON automatically and mix the nutrients thoroughly through agitation process.

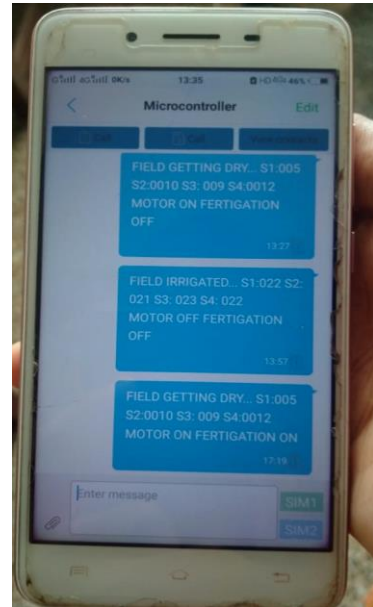
The capacitance value corresponding to the soil moisture content sensed by the capacitance probes is transferred to the micro controller unit. When the data received by the micro controller unit reaches below the lower limit pre-set value, the system automatically gets ON. Similarly when the soil moisture content

reaches the field capacity (upper limit of pre-set value), the system automatically goes OFF. Before and after irrigation a SMS will be sent automatically to the concerned user's mobile through GSM modem to update the status of motor and system. Display of the status and fertigation are shown in Fig 21, Fig.22 and Fig 23. The main advantages of the automated drip fertigation system developed in this study are:

- Automated drip fertigation system is easy to handle and highly economical as compared to other automated drip systems.
- Capacitance probes are highly sensitive, accurate, light weight and show high linearity between capacitance and soil moisture content, compared to resistant type sensors.
- Capacitance sensor is durable because it's made up of Teflon coating.
- Installation of system and operation of solenoid valves are very easy.
- Developed automated drip fertigation system costs only Rs. 24,000/- per acre and affordable by the marginal farmers.



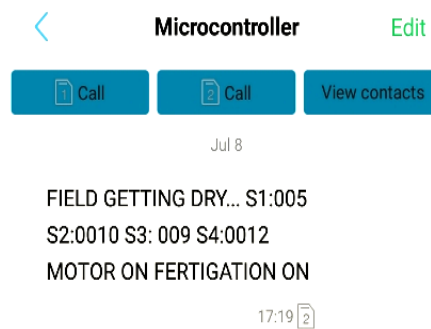
**Plate 19. Evaluation of capacitor type sensor**



**Fig. 21. Status message from the system before irrigation**



**Fig. 22. After irrigation status**



**Fig. 23. Fertigation scheduling status**



#### 4.4.1. Growth parameter

The crop parameters such as date of first flowering, fruit development and first and last harvesting were observed and given in Table 8 and different stages of crop growth are shown in Plate 20. Growth parameters such as height of the plant, number of leaves and stem girth were taken at 15, 30, 50 and 80 days after transplanting (DAP) are given in Table 9, 10 and 11. Variation in growth parameters for the treatments T1, T2 and T3 are shown in Fig. 24, 25 and 26. Weekly observation readings are given in Appendix III.

**Table 8. Growth parameters after DAP**

<b>Growth parameters</b>	<b>T1</b>	<b>T2</b>	<b>T3</b>
<b>Days of first flowering (DAP)</b>	50 days	56 days	53 days
<b>Days to fruit development (DAP)</b>	91 days	94 days	90 days
<b>Days to first harvest</b>	105 days	110 days	108 days
<b>Days to last harvest</b>	120 days	117 days	120 days

From the Table 8 it can be seen that days to first flowering, fruit development, first harvest and last harvest are less in treatment T1 i.e. within short period of time. T3 was almost similar to T1 and more number of days were taken in T2 from maturing stage to harvesting stage.



**Plate 20. Stages of plant growth**

**Table 9. Plant height during the crop growth period**

Treatment	Average plant height (cm)			
	15 DAP	30 DAP	50 DAP	80 DAP
T1	18.25	26.47	35.00	43.25
T2	15.63	20.99	31.15	36.00
T3	17.88	24.10	33.74	40.87

From the Table 9, it can be seen that the treatment T1 shows the better performance of plant height throughout the crop period. It can also be noted that the treatment T3 shows good performance almost on par with treatment T1, whereas treatment T2 shows poor performance when compared to other two treatments.

**Table 10. Number of leaves during the crop growth period**

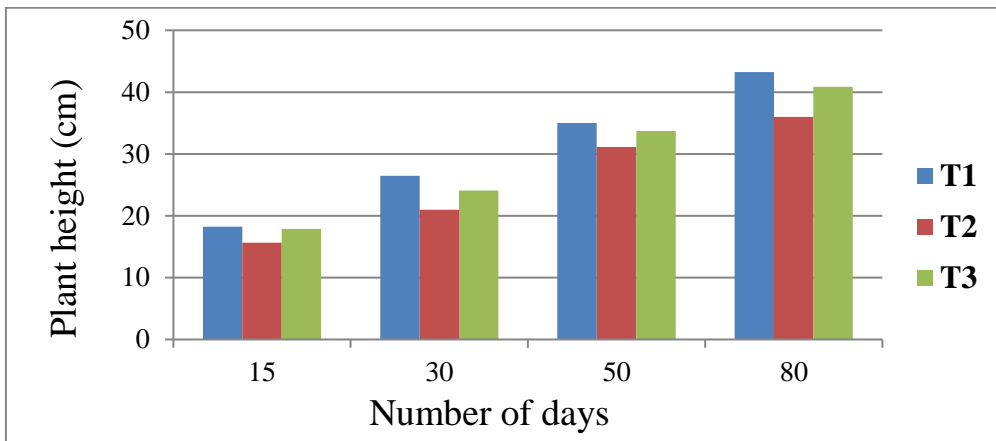
Treatment	Average number of leaves			
	15 DAP	30 DAP	50 DAP	80 DAP
T1	13	21	46	78
T2	8	14	34	66
T3	11	18	39	70

From the Table 10, shows that the number of leaves during 15 to 80 DAP were more in treatment T1 compared to treatments T2 and T3.

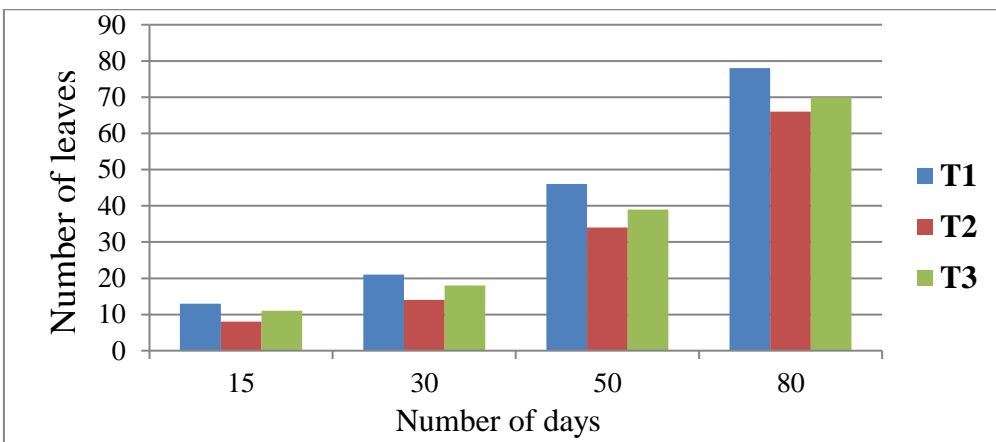
**Table 11. Stem girth during the crop growth period**

Treatment	Average stem girth (cm)			
	15 DAP	30 DAP	50 DAP	80 DAP
T1	0.9	1.3	2.6	3.8
T2	0.5	0.9	1.4	2.6
T3	0.7	1.1	1.9	3.8

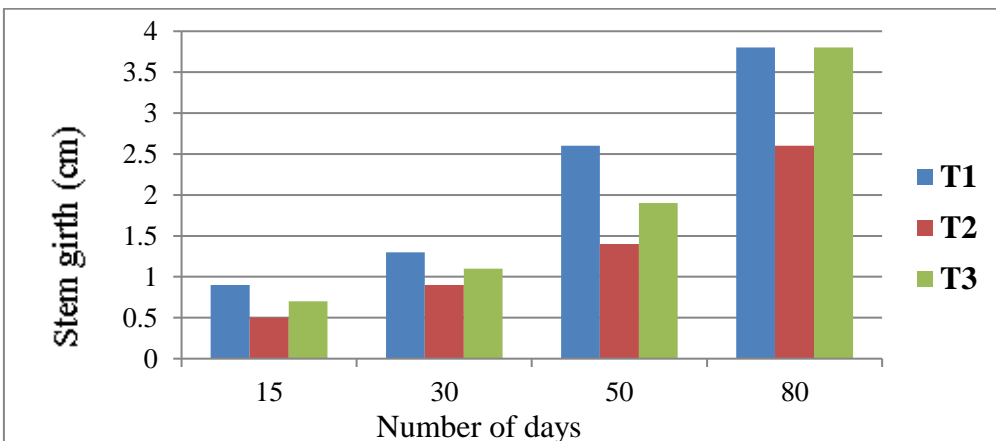
From the Table 11, it can be seen that the treatment T1 shows better stem girth throughout the crop period. The treatments T3 also have resulted in comparable stem girth and lowest performance was in treatment T2.



**Fig. 24. Variation in plant height of different treatments**



**Fig. 25. Variation in number of leaves of different treatments**



**Fig. 26. Variation in stem girth of different treatments**

#### 4.4.1.1. Statistical analysis

Statistical analysis was done for different treatments using the last day (95 DAP) observations of different crop growth parameters (Table 12) using R (Base and Agricolae Package software). The LSD tests for treatments are shown in Table 13, 14 and 15. The analysis of variance table is given in Appendix III.

**Table 12. Growth parameters of chilli crop (last observation)**

Treatment		Plant height (cm)	Number of leaves	Stem girth (cm)
T1	R1	47.7	85	3.2
	R2	44.6	88	3.1
	R3	47.2	86	3.3
	R4	47.4	86	3.4
	R5	46.1	84	3.3
	R6	43.8	81	3.1
T2	R1	32.8	75	2.5
	R2	28.1	67	2.4
	R3	35.5	73	2.5
	R4	36.0	73	2.2
	R5	34.9	74	3.1
	R6	34.3	65	2.6
T3	R1	40.3	84	2.9
	R2	39.1	86	2.9
	R3	40.9	79	3.2
	R4	39.6	81	3.0
	R5	42.6	83	2.6
	R6	38.8	82	2.9

**Table 13. LSD test for treatments based on plant height**

<b>Treatments</b>	<b>Plant height (cm)</b>
T1	46.13 <sup>a</sup>
T2	33.63 <sup>c</sup>
T3	40.25 <sup>b</sup>

From the comparison of means table by LSD test, it was observed that the plant height was varied significantly with the treatments. Highest plant height of 46.13 cm was obtained for treatment T1 and treatment T2 gave the lowest plant height (33.63 cm).

**Table 14. LSD test for treatments based on number of leaves**

<b>Treatments</b>	<b>Number of leaves</b>
T1	85.26 <sup>a</sup>
T2	70.89 <sup>b</sup>
T3	82.44 <sup>a</sup>

From the LSD test corresponding to number leaves in growth parameters the treatments T1 and T3 was having almost similar growth.

**Table 15. LSD test for treatments based on stem girth**

<b>Treatments</b>	<b>stem girth</b>
T1	3.23 <sup>a</sup>
T2	2.47 <sup>c</sup>
T3	2.89 <sup>b</sup>

From the comparison of means table by LSD test, it was observed that the stem girth was varied significantly with the treatments. Highest stem girth of 3.23 cm was obtained for treatment T1 and treatment gave the lowest stem girth 2.47 cm.

#### 4.4.2. Yield parameters

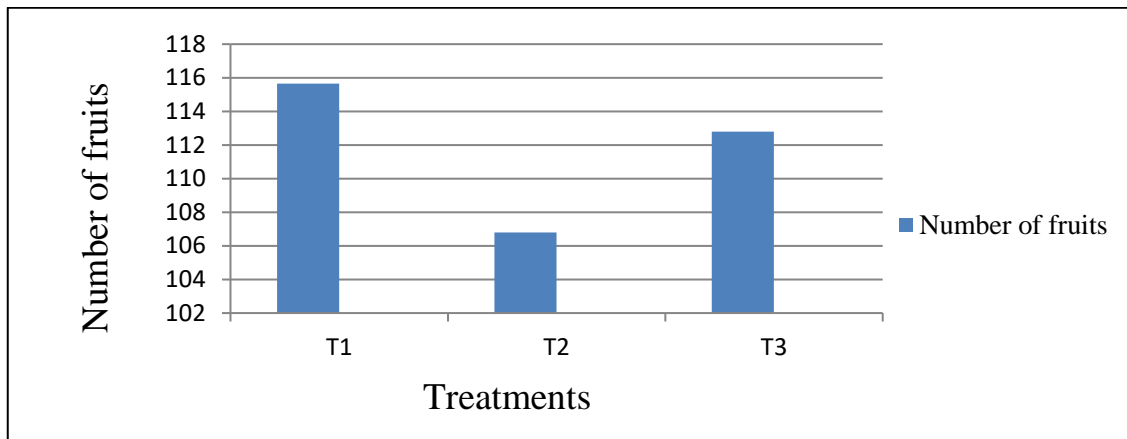
Yield parameters such as number of fruits per plant, fruit length and yield per plant were noted during the crop period and are shown in Table 16.

##### 4.4.2.1. Statistical analysis

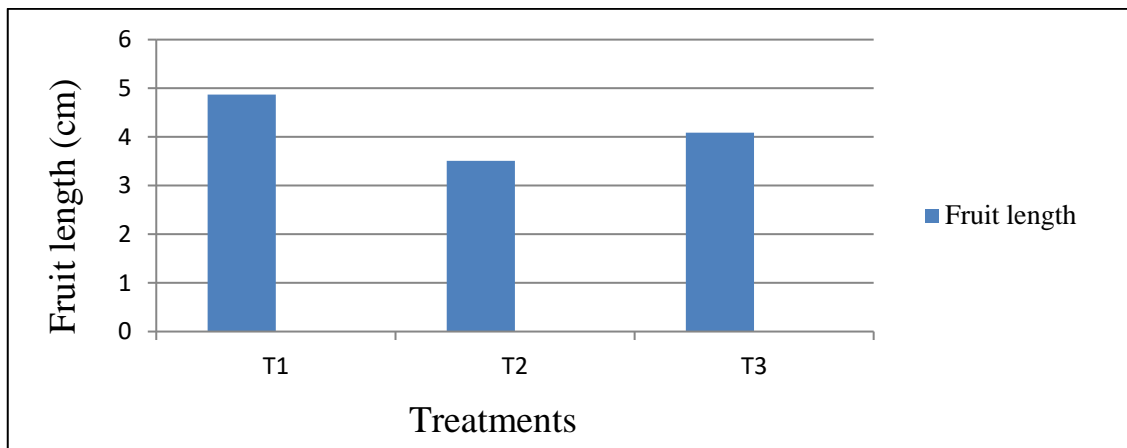
The statistical analysis using two way anova for different yield parameters observed were carried out with R (Base and Agricolae Package software). Variation in yield parameters for the treatments T1, T2 and T3 are shown in Fig. 27, 28 and 29. The LSD tests for treatments based on yield parameters are shown in Table 17, 18 and 19. Two way anova statistical analysis are in given in Appendix IV.

**Table 16. Yield parameters of chilli crop (last observation)**

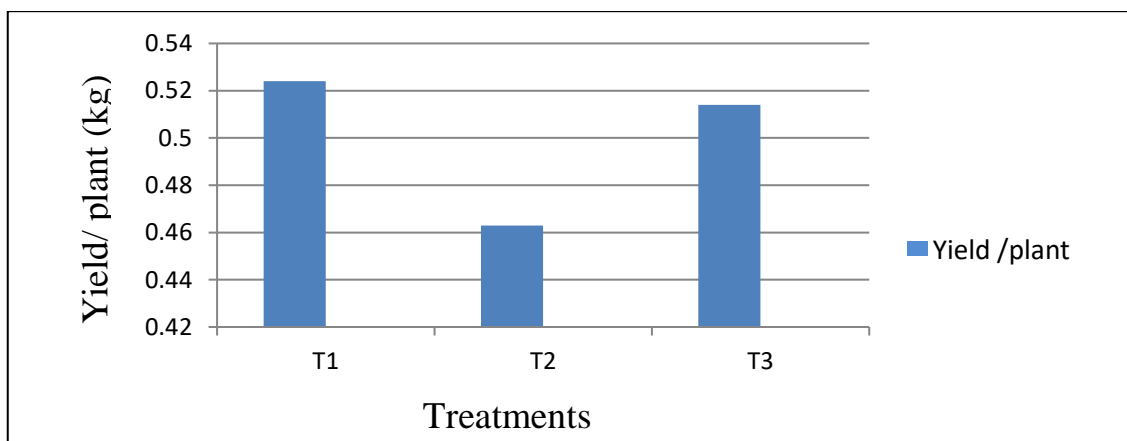
Treatment		Number of fruits/plant	Average fruit length (cm)	Average yield/plant (kg)	Average yield (t/ha)
T1	R1	120	4.74	0.506	14.56
	R2	117	5.05	0.528	
	R3	113	4.91	0.517	
	R4	115	5.00	0.537	
	R5	113	4.80	0.518	
	R6	116	4.70	0.540	
T2	R1	110	3.63	0.470	12.86
	R2	104	3.50	0.455	
	R3	108	3.57	0.477	
	R4	106	3.32	0.438	
	R5	105	3.60	0.471	
	R6	108	3.44	0.467	
T3	R1	125	3.63	0.515	14.28
	R2	113	4.50	0.524	
	R3	110	3.60	0.504	
	R4	108	3.98	0.534	
	R5	110	4.60	0.521	
	R6	111	4.20	0.485	



**Fig. 27. Variation in number of fruits of different treatments**



**Fig. 28. Variation in fruit length of different treatments**



**Fig. 29. Variation in fruit weight of different treatments**



The variation in average number of fruits, fruit length and yield per plant are shown using bar graphs in Fig. 21 to 23. The highest number of fruits of 117 per plant, fruit length of 5.05 cm and yield per plant of 0.524 kg were obtained from T1. The yield parameters observed from T3 were on par with the T1 and yield per plant was 0.514kg. The performance of the treatment T2 was poor when compared to other two treatments and it gave the lowest yield per plant, which was 0.463 kg.

**Table 17. LSD test for treatments based on number of fruits/plant**

Treatments	Number of fruits/plant
T1	115.77 <sup>a</sup>
T2	106.67 <sup>b</sup>
T3	112.92 <sup>a</sup>

Based on LSD test, the yield parameters such as number of fruits per plant was almost similar in treatments T1 and T3, whereas less number of fruits per plant (106.67) was obtained from T2.

**Table 18. LSD test for treatments based on fruits length (cm)**

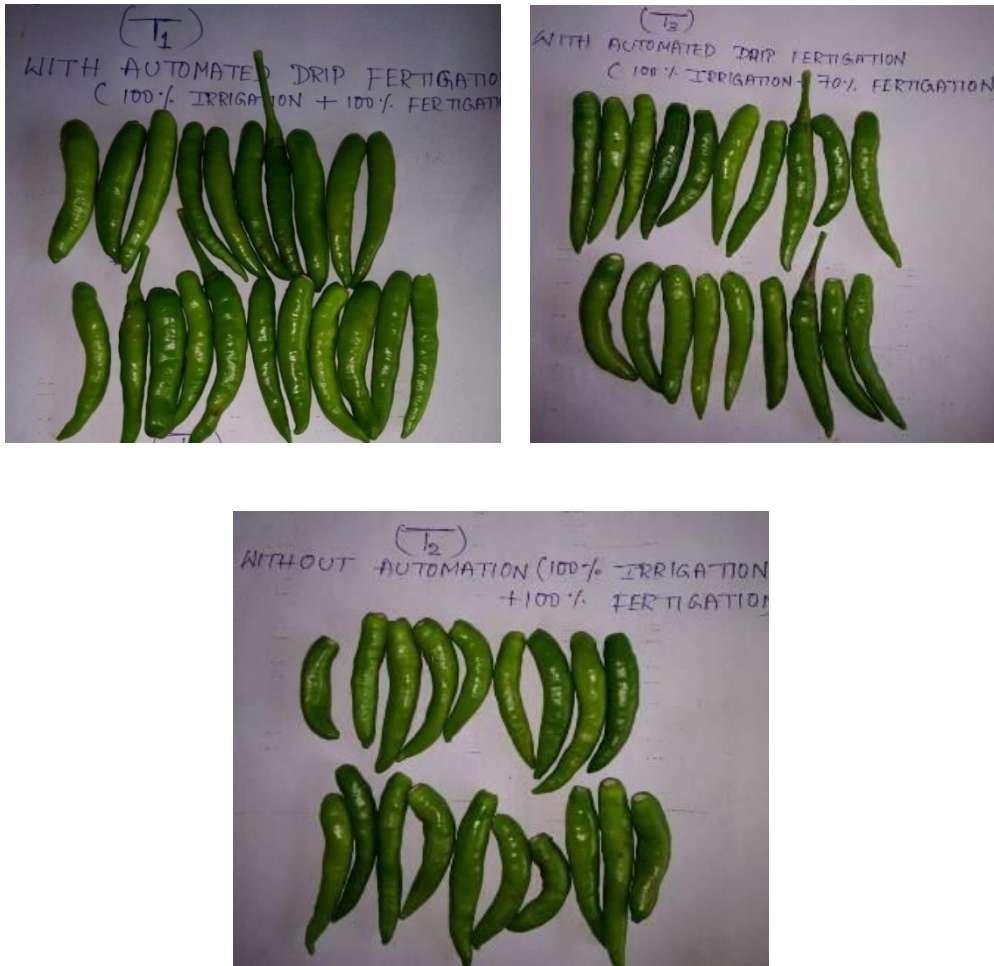
Treatments	Fruit length (cm)
T1	4.86 <sup>a</sup>
T2	3.51 <sup>c</sup>
T3	4.25 <sup>b</sup>

From the LSD test corresponding to fruit length, it could be seen that the treatment T1 gave highest value and T3 gave somewhat lower value than T1. The lowest fruit length was observed in treatment T2.

**Table 19. LSD test for treatments based on yield per plant (kg)**

Treatments	Yield/plant (kg)
T1	0.524 <sup>a</sup>
T2	0.463 <sup>b</sup>
T3	0.514 <sup>a</sup>

Based on LSD test, yield per plant was almost similar in treatments T1 and T3, whereas less yield per plant of 106.67 was obtained from T2.



**Plant 21. Comparison of fruit size**

From the field experiment, it could be seen that the highest yield of 14.56 t/ha was obtained from the treatment T1 and yield of 14.28 t/ha from treatment T3, which is on par with T1. Poor crop performance and less yield was obtained from treatment T2 i.e 12.86 t/ha.

#### 4.4.3. Cost analysis of automated drip fertigation system

Cost analysis of the automated drip fertigation system for different treatments was carried out and was compared with traditional irrigation system. The Benefit - cost (B:C) ratio was calculated and the calculations are given in Table 20.

**Table 20. Comparison of cost economics of different irrigation methods**

Item	With automated drip fertigation (T1)	Drip irrigation Without automation (T2)	With automated drip fertigation (T3)	Surface flooding (traditional method)
Cost of drip system + automation	2,52,000 + 24000	2,52,000	2,52,000 + 24000	
Considering depreciation (the drip System can use at least 6 seasons) and automation for 3 seasons	50,000	42,000	50,000	--
Cost of cultivation Rs /ha/season	27,000	27,000	27,000	27,000
Total fertilizer cost Rs./ha/season	8,000	8,000	5,600	8,000
Labour cost Rs. / ha/ season	12,000	17,000	12,000	43,000
Total cost, Rs./ ha/season	97,000	94,000	94,600	78,000
Yield, (t/ha)	14.56	12.86	14.28	10.00
Cost of chilli, Rs./kg	25	25	25	25
Revenue, Rs./ha	3,64,000	3,21,500	3,57,000	2,50,000
Benefit cost ratio	<b>3.75</b>	<b>3.42</b>	<b>3.77</b>	<b>3.20</b>

From the table it can be seen that the highest benefit cost ratio of 3.77 was obtained from treatment T3 and that of treatment T1 was 3.75. This shows that with 30 per cent less fertilizer, better performance of crop was obtained using automated drip fertigation system.

## CHAPTER 5

### SUMMARY AND CONCLUSIONS

Precise control, effective use of water and fertilizers in agriculture can be achieved only through automated drip fertigation system. This study was conducted to develop a cost effective automated drip fertigation system based on GSM modem. The drip fertigation system consists of capacitor type soil moisture sensors to perform precise application of water to the plant according to crop water requirement. The experiments were done in the laboratory and in an open field. For easy operation and accurate results the capacitance probe was developed using Teflon coating.

The automated drip fertigation system consists of four capacitance sensors, two solenoid valves, electronic fertilizer pump, fertilizer mixing device, micro controller system and LCD display. System will start the irrigation automatically when the soil moisture content reaches to 50 % depletion of the available moisture content (FC-PWP). The system will run automatically according to pre-set limits and the message of ON and OFF status will be sent to the concerned user for his knowledge.

Calibration tests were carried out in the Soil and Water Engineering Laboratory, KCAET, Tavanur by using three different soil types collected from different places. The capacitance sensors were calibrated using laterite soil, black soil and coastal alluvium soil. Calibration curves were drawn with soil moisture content against capacitance. The capacitance sensors showed high linearity between soil moisture content and capacitance. Laterite soil showed a linear relationship of soil moisture content and capacitance value of the probe. Black soil showed non-uniform variation in the sensor capacitance value when the soil moisture content reduced below the field capacity. While in the case of coastal alluvium soil the capacitance value reduced slowly after the field capacity.

Field study was conducted in the open field of KVK, Malappuram, KCAET campus. The KAU chilli variety 'Ujwala' - CA 219-1-19-6 (*Capsicum annum*), was used for the field experiment. One month old chilli seedlings were transplanted in 9 beds representing three treatments and six replications. Crop growth parameters such as height of the plant, number of leaves, fruits and stem girth were noted at 15, 30, 50 and 80 days after transplanting and yield parameters such as fruit weight, fruit length and yield per plant were noted during the crop period.

The following treatments were selected for this study.

- T1-100 percent fertigation and 100 percent irrigation (with automated drip fertigation)
- T2-100 percent fertigation and 100 percent irrigation (without automation)
- T3-100 percent irrigation and 70 percent fertigation (with automated drip fertigation)

The combination of 100% irrigation and 100% fertigation using automated drip fertigation system (T1) gave the highest yield, whereas 100% irrigation and 70% fertigation (T3) gave the results on par with T1 by reducing the fertilizer intake by 30 per cent.

**From the results obtained, the following conclusions were drawn**

- The GSM based automated drip irrigation system available in market are costly (more than Rs.55000/-) and not affordable by small scale marginal farmers having limited land area.
- The developed automated drip fertigation system in this current study costs only Rs. 24,000/- and easy to operate. Hence the developed system can be considered as cost effective.

- The automated system consists of capacitance sensors which are more accurate than existing soil moisture sensors.
- In the past studies, automation system and motor were operated using 'SMS' from mobile phones through GSM technology. But in the present study the system works automatically and GSM was used only for getting the motor status.
- Automated drip fertigation system based on GSM technology gave best results and is suitable for different soil conditions.
- 100 % irrigation and 100% fertigation (T1) with automation gave the highest yield and good fruit quality.
- 100% irrigation and 100 % fertigation (T2) without automation gave the lowest yield and poor crop quality, due to the lack of efficient water and fertilizer application in time according to crop requirement. With automated drip fertigation, water is applied when 50 per cent of available water is depleted in the root zone and thereby water stress can be minimized on crop at any time.
- The results obtained from (T3), i.e. combination of 100% irrigation and 70% fertigation with automation was on par with T1.
- Hence, it could be concluded that with 30 percent less fertilizer, better performance of crop was obtained using automated drip fertigation system.
- So we can suggest this cost effective and user friendly drip fertigation system to the marginal farmers.

### **Future recommendation**

- Future research may be carried out by using wireless sensor and nutrition sensor, which can help to improve the crop production i.e. more yield using less water and fertilizer.
- GPRS system can be used for the data transfer to the network.
- Solar system can be used as the power source for the developed system.



## *References*



## REFERENCES

- Adamchuk, V.I., Hummelb, J.W., Morganc, M.T., and Upadhyayad, S.K. 2004. On-the-go soil sensors for precision agriculture. *Computers and Electronics in Agriculture*. 44: 71–91.
- Ali Fares, Ashok Kumar, A., Peter Nkedi-Kizza, and Elrashidi, M. A. 2000. Estimation of Soil Hydraulic Properties of a Sandy Soil Using Capacitance Probes and Guelph Permeameter<sup>1</sup>. *J. Soil.Sci.* 165(10):768-777.
- Ali Neshat and Shima Nasiri. 2012. Finding the Optimized Distance of Emitters in the Drip Irrigation in Loam-Sandy Soil in the Ghaeme Abad Plain of Kerman, Iran. *Middle-East. J. Sci. Res.* 11 (4): 426-434.
- Antonio, V., Abalos, D., Jeffery, S., and Sanz-Cobena, A. 2014. Meta-analysis of the effect of urease and nitrification inhibitors on crop productivity and nitrogen use efficiency. *Agriculture, Ecosystems and Environment*. 189: 136-144.
- Arjun Prakash, K.V., Sajeena, S., and Lakshminarayana, S.V. 2017. Field Level Investigation of Automated Drip Irrigation System. *Int.J.Curr.Microbiol.App.Sci.* 6(4): 1888-1898.
- Awati, J.S., Patil, V.S., and Awati, S.B. 2012. Application of wireless sensor networks for agriculture parameters. *Int. J. Agri. Sci.* 4(3):0975-3710, pp-213-215.
- Baljit, K., and Dilip, K. 2013. Development of automated nutrients composition control fertigation system. *Int. J. Com. Sci. Eng. Appli.* 3(3).
- Bozkurt, S., Mansuroglu, G. S., Kara, M., and Onder, S. 2009. Response of lettuce to irrigation levels and nitrogen forms. *Afr. J. Agric. Res.* 4(11): 11711177.
- Bristow, K.L., Kluitenberg, G.J., Goding, C.J., and Fitzgerald, T.S. 2001. A small multi-needle probe for measuring soil thermal properties, water content and

- electrical conductivity. *Computers and electronics in agriculture*. 31 (3): 265-280.
- Campbell, G.S., and Mulla, D.J. 1990. Measurement of soil water content and potential. *J. American Soc. Agronomy*. 6(30).
- Central Ground Water Board (CGWB), INDIA-WRIS Portal. 2011.
- Cristian Iacomi, Ioan Roùca, Roxana madjar, Beatrice Iacomi, Viorel popescu, Gaudengiu vãrzar, and Cãtãlin sfetcu. 2014. Automation and computer-based technology for small vegetable farm holder. *J. Agronomy*. 7: 2285-5785.
- Danish, I., Akash, P., Vishal, R., Nayan, P., and Saluja, B.K. 2016. Automated Drip Irrigation System based on Embedded System and GSM Network. *Int. J. Inno. Res .Com. Commun. Eng*. 3(5): 2320-9801.
- Dean, T.J., Bell, J.P., and Baty, A.J.B. 1987. Soil moisture measurement by an improved capacitance technique, part I. sensor design and performance. *J. of hydrology*, 93: 67-78.
- Eller, H., Thomas, A., and Bettina Engelbrecht, M. J. 1996. A comparison of methods for determining soil water availability in two sites. *Journal of Tropical Ecology*. 21:297–305.
- Evans, R, Cassel, K.D., and Sneed, E.R. 1996. Measuring soil water for irrigation scheduling: monitoring methods and devices. *North Carolina Cooperative Extension*. 452-2.
- Giri M. and Wavhal, D. N. 2013. Automated intelligent wireless drip irrigation using linear programming. *Int. J. Adv. Res. Comput. Eng. Technol*. 2 (1)
- Guerbaoui. M., and El afou, Y. 2013. Pc-based automated drip irrigation system. *Int. J.Eng. Sci. Technol*. 5(1): 0975-5462.

- Gulshan Mahajan and Singh, K.G. 2006. Response of green house tomato to irrigation and fertigation. *Agric. Water Manag.* 84: 202-206.
- Gutierrez, J., Medina, J. F. V., Garibay, A. N., and Gandara, M. A. P. 2013. Automated Irrigation System Using a Wireless Sensor Network and GPRS Module. *IEEE Trans. Instrum. Measurement.*
- Hade, A. H. and Sengupta, M. K. 2014. Automatic irrigation of drip irrigation system & monitoring of soil by wireless. *IOSR J. Agric. Vet. Sci.* 7(4):57-61.
- Hasan, M., Sirohi, N.P.S., Kumar, V., and Sharma, M.K. 2004. Performance Evaluation of Different Irrigation Scheduling Methods for Peach through Efficient Fertigation System Network. *Acta Hort.* 662(1).
- Hebbar, S.S., Ramachandrapaa, B.K., Nanjappaa, H.V., Prabhakar, M. 2004. Studies on NPK drip fertigation in field grown tomato (*Lycopersicon esculentum* Mill.). *J. Agronomy.* 21: 117-127.
- Heng, L.K., Casanova, J.J., Schwartz, R.C. 2003. Soil water sensing for water balance, ET, WUE. *Agric. Water Manag.* 104:1-9.
- Jayakumar, M., Surendran, U., and Manick sundaram P. 2014. Drip fertigation effects on yield, nutrient uptake and soil fertility of Bt Cotton in semi arid tropics. *Int. J. Plant Production.* 8 (3): 1735-6814.
- John, W.D., and Michael, R. Zeiss. 1996. Soil health and sustainability. *Applied soil ecology.* 15: 3–11.
- Kanislaw, S. and Dysko, J. 2008. Effect of drip irrigation and cultivation methods on the yield and quality of parsley roots. *J. Elementol.* 13(2): 235-244.
- Konstantinos X. Soulis, Stamatios Elmaloglou, and Nicholas Dercas 2015. Investigating the effect of soil moisture sensors positioning and accuracy on soil moisture based drip irrigation scheduling systems. *Agric. Water Manag.* 148: 258-268.

- Kuligud, V.B. Salimath, S.B., Jayashekhar K.V., Upperi S.N., and Balakrishnan P., 1999. Application of Em38 for soil salinity appraisal: an Indian experience. International institute for land reclamation and improvement, Wageningen, Netherlands.
- Lawrence, R., Parsons, W., and Bandaranayake, M. 2009. Performance of a New Capacitance Soil Moisture Probe in a Sandy Soil. *Soil Sci. Soc. Am. J.* 73:1378-1385.
- Mahir Dursun and Semih Ozden. 2011. A wireless application of drip irrigation automation supported by soil moisture sensors. *Scientific Research and Essays.* 6(7), pp. 1573-1582.
- Mahmoud Ibrahim, M., El Baroudy, A.A., Ahmed Taha, M. 2015. Irrigation and fertigation scheduling under drip irrigation for maize crop in sandy soil. *International Agrophysics.* 30(1).
- Majone, B., Viani, F., Filippi, E., Bellin, A., Massa, A., Toller, G., Robol, F., and Salucci, M. 2013. Wireless Sensor Network deployment for monitoring soil moisture dynamics at the field scale. *Procedia Environ. Sci.* 19:426- 435.
- Mark, C., Rosegrant, M.W., Zhu, T. 2002. Water for agriculture: maintaining food security under growing scarcity. *Annual Review of Environment and Resources.* 35:205-222.
- Mbah, C.N. 2012. Determining the field capacity, wilting point and available water capacity of some Southeast Nigerian soils using soil saturation from capillary rise. *Nij. J. of BioTech.* 24: 41-47.
- McCready, M.S., Dukes, M.D., and Miller, G.L. 2009. Water conservation potential of smart irrigation controller on St. Augustinegrass. *Agric. Water Manag.* 96: 1623-1632.
- Michael, A. M. 2008. *Irrigation Theory and Practice*, (2<sup>nd</sup> Ed.). Vikas Publishing House PVT LTD. New Delhi. 459p.

- Michael, D. D., and Stacia, L.D. 2003. Methodologies for Successful Implementation of Smart Irrigation Controllers. *J. Irri. Drainage. Eng.* 141(3):04014055.
- Miller, G. A., Farahani, H. J., Hassell, R. L., Khalilian, A., Adelberg, J. W. and Wells, C. E. 2014. Field evaluation and performance of capacitance probes for automated drip irrigation of watermelons. *Agric. Water Manag.* 131: 124-134.
- Mohd Salih, J. E., Adom, A. H., and Md Shaakaf, A.Y. 2012. Solar Powered Automated Fertigation Control System for Cucumis Melo L. Cultivation in Green House. *J. Procedia Engineering.* 4:79-87.
- Morgan, N. E., Bratieres, K., Fletcher T. D., Deletic, A., and Zinger, Y. 1998. Variation of electrical conductivity in distributed systems: optimization study. *Water Res.* 42(14):393-398.
- Nazirbay Ibragimov, Steve Evett, and Yusupbek Esanbekov. 2007. Water use efficiency of irrigated cotton in Uzbekistan under drip and furrow irrigation. *Agric. Water Manag.* 17(140).
- Nemali, K. S. and Iersel, V. M. W. 2006. An automated system for controlling drought stress and irrigation in potted plants. *Scientia Hortic.* 110:292297
- Nemali, K. S., Montesano, F., Dove, S. K., and Iersel, V. M. W. 2007. Calibration and performance of moisture sensors in soilless substrates: ECH2O and theta probes. *Scientia Hortic.* 112: 227-234.
- Nikolidakis, S. A., Kandris, D., Vergados, D. D., and Douligeris, C. 2015. Energy efficient automated control of irrigation in agriculture by using wireless sensor networks. *Comput. Electr. Agric.* 113:154-163.
- NITI Aayog, Water and Agriculture in India, 2015.

- Noborio, K. 2001. Measurement of soil water content and electrical conductivity by time domain reflectometry: a review. *Comput. Electr. Agric.* 31:213-237.
- Osroosh Robert, Y., Troy Peters Colin, and Campbell, S. 2016. Comparison of irrigation automation algorithms for drip-irrigated apple trees. *Computers and Electronics in Agriculture.* 128:87-99.
- Pandey, A. K., Singh, A. K., Kuma, A., and Singh, S. K. 2013. Effect of Drip Irrigation, Spacing and Nitrogen Fertigation on Productivity of Chilli (*Capsicum annuum L.*). *Environment & Ecology.* 31 (1): 139—142.
- Patil, M., Mishra, N.N., Pankaj, S.K. 2014. World population stabilization unlikely this century. *American Association for the Advancement of Science.* 346:234-237.
- Pavithra, D., and Ranjit, B. 2014. IoT based Monitoring and Control System for Home Automation. *Global Conference on Communication Technologies.* 2 : 2-13.
- Prathyusha, K. and Chaitanya, S. 2012. Design of Embedded System for the automation of Drip Irrigation. *Int. J. Appl. Innovation Eng. Manag.* 1: 254-258.
- Punmia, B. C., Jain, A. K., and Jain, A. K. 2005. *Soil Mechanics And Foundations*, (16th Ed.). Laxmi Publications (P) LTD. New Delhi. pp.44-46.
- Purnima, and Reddy, S.R.N. 2012. Design of Remote Monitoring and Control System with Automatic Irrigation System using GSM-Bluetooth. *Int. J. Com. App.* 47(12).
- Rahali, A., Guerbaoui, M., Ed-dahhak, A., El Afou, Y., Tannouche, A., Lachhab, A., and Bouchikhi, B. 2011. Development of a data acquisition and greenhouse control system based on GSM. *Int. J. Eng. Sci. Technol.* 3(8).pp.297-306.

- Rane, D., Indurkar, P. R., and Khatri, D. M. 2015. Review paper based on automatic irrigation system based on RF module. *Int. J. Adv. Inf. Commun. Technol.* 1(9).
- Ravi, B., Sujatha, S., Balasimha, D. 2007. Impact of drip fertigation on productivity of Arecanut. *Agric. Water Manag.* 90: 1-2.
- Robinson, D. A., Gardner, C. M. K., and Cooper, J. D. 1999. Measurement of relative permittivity in sandy soils using TDR, capacitance and theta probes: comparison, including the effects of bulk soil electrical conductivity. *J. Hydrol.* 223:198-211.
- Romero, R., Muriel, J.L., Garcia, I., and Munoz de la Pena, D. 2012. Research on automatic irrigation control: State of the art and recent results. *Agric. Water Manag.* 114:59-66
- Rui Zhang, Ziyong Cheng, Jinxia Zhang and Xuewei Ji. 2012. Sandy Loam Soil Wetting Patterns of Drip Irrigation: a Comparison of Point and Line Sources. *J. Procedia Engineering.* 28: 506 – 511.
- Samsuri, Saiful Farhan, M., Robiah, A., and Mohamed Hussein. 2010. Development of Nutrient Solution Mixing Process on Time-Based Drip Fertigation System. *Fourth Asia International Conference.* 110:pp.292–297.
- Seyfried, M. S. and Murdock, M. D. 2001. Response of a new soil water sensor to variable soil, water content and temperature. *Soil Sci. Soc. Am. J.* 65:2834.
- SFU Soil Science. 2012. Hydrometer Method.
- Sharma, N., Hakkim, A. V. M., and Kumar, A. 2015. Performance of low cost soil moisture sensor based on electrical conductivity on varying salinity level of irrigation water. *J. Soil Water Conserv.* 14 (3).
- Shaymaa Shedeed, I., Sahar Zaghlou, M., and Yassen, A. A. 2009. Effect of Method and Rate of Fertilizer Application under Drip Irrigation on Yield and Nutrient Uptake by Tomato. *Ozean journal of applied sciences.*

2(2):1943-2429.

- Shock, C., Erik Feibert, and Scott Jaderholm. 2001. A comparison of six soil moisture sensors. *Proceedings of the International Irrigation*. 143(156).
- Singandhupe, R.B., Rao, G.G.S.N., Patil, N.G., and Brahmanand, P.S. 2003. Fertigation studies and irrigation scheduling in drip irrigation system in tomato crop (*Lycopersicon esculentum* L.). *J. Agronomy*. 19: 327-340.
- Siyal, A.A., Skaggs, T.H. 2009. Measured and simulated soil wetting patterns under porous clay pipe sub-surface irrigation. *Agric. Water Manag.* 93: 893-904.
- Stafford, J. V. 1988. Remote, non-contact and in situ measurement of soil moisture content: A review. *J. Agric. Eng. Res.* 41(3): 151-172
- Stambouli, T., Faci, J.M., Zapata, N. 2014. Water and energy management in an automated irrigation district. *Agric. Water Manag.* 142: 66-76.
- Sudduth, K. A., Kitchen, N. R., Wiebold, W. J., Batchelor, W. D., Bollero, G. A. and Bullock, D. G. 2005. Relating apparent electrical conductivity to soil properties across the north-central USA. *Comput. Electr. Agric.* 46:263283.
- Sukhjit Singh and Neha Sharma. 2012. Drip Irrigation management using wireless sensors. *Int. J. Sci. Eng. Res.* 3(9).
- Surendran, U., Sandeep, O., and Joseph, EJ. 2016. The impacts of magnetic treatments of irrigation water on plant, water and soil characteristics. *Agric. Water Manag.* 178:21-29.
- Takele Gadissa, and Desalegn Chemedda. 2009. Effects of drip irrigation levels and planting methods on yield and yield components of green pepper (*Capsicum annum*, L.) in Bako, Ethiopia. *Agric. Water Manag.* 96: 1673-1678.
- (TISS), Tata Institute of Social Sciences. Water and Agriculture in India. 2017.



- Thakur, D. S., Sharma, A., and Sharma, D. K. 2013. A low cost design & monitoring of automatic irrigation system based on zigbee technology. *Int. J. Eng. Res. Technol.* 2(5).
- Thompson, R. B., Gallardo, M., Valdez, L. C., and Fernandez, M. D. 2007. Determination of lower limit for irrigation management using in situ assessments of apparent crop water uptake made with volumetric soil water content sensors. *Agric. Water Manag.* 92:13-28.
- Tiwari, K.N., Mal, P.K., Singh, R.M., Chattopadhyay, A. 1998. Response of okra (*Abelmoschus esculentus* (L.) Moench.) to drip irrigation under mulch and non-mulch conditions. *Agric. Water Manag.* 38:91-102.
- Turrall, Hao and Shen, 2011. Earth Observation and Climate Services for Food Security and Agricultural Decision Making in South and Southeast Asia *J. Applied meteorology and climatology.* 6(100).
- Tyronese Jackson, Katrina Mansfield, Mohamed Saafi, Tommy Colman, Peter Romine. 2008. Measuring soil temperature and moisture using wireless MEMS sensors. *J. Measurement.* 41:381-390.
- Vandana, D., Nilesh, D., Shailesh singh, C. 2011. Wireless Sensor Network based Remote Irrigation Control System and Automation using DTMF code. *J. Communication Systems and Network Technologies.* 446-448.
- Vijayakumar, G., Tamilmani, D., and Selvaraj, P. K. 2010. Irrigation and fertigation scheduling under drip irrigation in brinjal crop. *Int. J. Bio Resour. Stress. Manag.* 1(2): 72-76.
- Vittal, B.K., Shirahatti, B. M., Dodamani and balakrishnan, P. 1999. Studies on salt and water balance in secondary salinised deep black soils. *Soil Sci. Soc. Am. J.* 60 (5):1536-1540.
- Wang, D. 2014. FDC1004: basics of capacitive sensing and applications. Texas instruments.

White, I., Knight, J.H., and Zegelin, G.C. 1994. Considerations on the use of time-domain reflectometry (TDR) for measuring soil water content. *European. J. Soil. Sci.* 45:503-508.

Zotarelli, L., Dukes, M. D., Scholberg, J. M. S., Femminella, K., and Muñoz-Carpena, R. 2010. Irrigation Scheduling for Green Bell Peppers Using Capacitance Soil Moisture Sensors. *J. Irrig. Drain Eng.* 137:73-81.

## *Appendices*

**Appendix I: Particle size analysis of different types of soils (Sieve analysis)**

Total dry weight of laterite soil = 1000g

Total dry weight of black soil = 1000g

Total dry weight of coastal alluvium soil = 1000g

Reading of sieve analysis

Sieve size	Sieve weight (g)	Weight of soil retained (g)		
		Coastal alluvium	Laterite soil	Black soil
2mm	360	0.530	622.8	561.0
1mm	370	3.880	63.80	75.00
600 $\mu\text{m}$	330	829.0	41.20	110.0
425 $\mu\text{m}$	335	23.80	24.20	61.86
300 $\mu\text{m}$	340	51.06	43.40	75.00
212 $\mu\text{m}$	340	74.65	176.4	80.00
150 $\mu\text{m}$	335	6.000	3.200	7.000
75 $\mu\text{m}$	295	4.760	14.80	19.75
Receiver	310	6.000	11.00	10.00

## Appendix II: Particle size analysis of different types of soils (Sedimentation analysis)

Sedimentation analysis (hydrometer method)

Weight of the sample taken= 30 g

Capacity of cylinder= 1000 ml

Diameter of the cylinder= 6.8 cm

Difference in graduation of cylinder= 2.4 cm

Height of hydrometer bulb= 16 cm

$$V_h / A = 2.6 \text{ cm}$$

Sample calculation

Effective depth,  $H_e = H + 1/2(h - (V_h / A))$

$$H_e = 8 + 1/2(16 - 2.6)$$

$H_e = 14.7 \text{ cm}$  Diameter of the particle,  $D = 10^{-5} F (H_e/t)^{1/2}$

$$F = 1352.97$$

$$D = 0.0733 \text{ cm}$$

$$N' = [100 G / (W_d (G-1))] * R_h$$

$$N' = [267 / (30 * 1.67)] * 8$$

$$N' = 42.6347$$

$$N = N' * (M' / M)$$

$$N = 42.6347 * (4038 / 5555)$$

$$N = 30.9917$$

## Sedimentation analysis (hydrometer method) of laterite soil

<b>Time (min)</b>	<b>Reading</b>	<b>Rh</b>	<b>He (cm)</b>	<b>D (cm)</b>	<b>N'</b>	<b>N</b>
0.5	1.008	8	14.7	0.0733	42.6347	30.9917
1	1.0075	7.5	14.2	0.0509	39.97	29.0547
2	1.007	7	13.7	0.0354	37.3053	27.1177
4	1.0063	6.3	13	0.0243	33.5748	24.4059
8	1.0058	5.8	12.5	0.0169	30.9101	22.469
15	1.0049	4.9	11.6	0.0118	26.1137	18.9824
30	1.0037	3.7	10.4	0.0079	19.7185	14.3336
60	1.003	3	9.7	0.0054	15.988	11.6218
120	1.0019	1.9	8.6	0.0036	10.1257	7.3605

## Sedimentation analysis (hydrometer method) of black soil

<b>Time (min)</b>	<b>Reading</b>	<b>Rh</b>	<b>He (cm)</b>	<b>D (cm)</b>	<b>N'</b>	<b>N</b>
0.5	1.0079	7.9	14.6	0.0731	42.1017	26.7774
1	1.0073	7.3	14	0.0506	38.9041	24.7437
2	1.007	7	13.7	0.0354	37.3053	23.7268
4	1.0061	6.1	12.8	0.0242	32.5089	20.6762
8	1.0056	5.6	12.3	0.0167	29.8443	18.9814
15	1.0052	5.2	11.9	0.0120	27.7125	17.6256
30	1.0041	4.1	10.8	0.0081	21.8502	13.8971
60	1.0034	3.4	10.1	0.0055	18.1197	11.5244
120	1.0023	2.3	9	0.0037	12.2574	7.7959

## Sedimentation analysis (hydrometer method) of coastal alluvium

<b>Time (min)</b>	<b>Reading</b>	<b>Rh</b>	<b>He (cm)</b>	<b>D (cm)</b>	<b>N'</b>	<b>N</b>
0.5	1.0056	5.6	12.3	0.0671	29.8443	0.1316
1	1.0053	5.3	12	0.0468	28.2455	0.1246
2	1.005	5	11.7	0.0327	26.6467	0.1175
4	1.0048	4.8	11.5	0.0229	25.5808	0.1128
8	1.0045	4.5	11.2	0.0160	23.9820	0.1058
15	1.004	4	10.7	0.0114	21.3173	0.0940
30	1.0035	3.5	10.2	0.0078	18.6526	0.0823
60	1.003	3	9.7	0.0054	15.9880	0.0705
120	1.0022	2.2	8.9	0.0036	11.7245	0.0517



**Appendix II: Weekly observation readings**Observation of growth parameters on March 20<sup>th</sup>

<b>Treatment</b>		<b>Plant height (cm)</b>	<b>Number of leaves</b>	<b>Stem girth (cm)</b>
T1	R1	18.86	10	1.0
	R2	17.92	16	0.5
	R3	18.64	11	0.9
	R4	16.90	8	1.2
	R5	18.48	10	0.8
	R6	18.75	13	0.7
T2	R1	14.77	6	0.6
	R2	13.72	9	0.4
	R3	15.96	8	0.5
	R4	16.52	7	0.8
	R5	15.87	11	0.6
	R6	15.48	9	0.4
T3	R1	17.98	9	0.8
	R2	15.41	17	0.6
	R3	17.63	8	0.7
	R4	16.77	6	1.0
	R5	18.21	8	0.7
	R6	18.44	11	0.5

Observation of growth parameters on April 5<sup>th</sup>

<b>Treatment</b>		<b>Plant height (cm)</b>	<b>Number of leaves</b>	<b>Stem girth (cm)</b>
T1	R1	28.86	20	1.5
	R2	17.92	26	1.0
	R3	18.64	17	1.1
	R4	26.90	14	1.2
	R5	28.48	20	0.9
	R6	30.75	23	0.7
T2	R1	20.77	10	0.9
	R2	13.72	19	0.8
	R3	16.96	11	1.0
	R4	21.52	17	0.8
	R5	21.87	16	0.7
	R6	25.48	19	0.5
T3	R1	27.98	19	0.8
	R2	15.41	22	0.9
	R3	17.63	12	0.7
	R4	26.77	18	1.1
	R5	28.39	17	0.7
	R6	28.44	21	1.5

Observation of growth parameters on April 30<sup>th</sup>

<b>Treatment</b>		<b>Plant height (cm)</b>	<b>Number of leaves</b>	<b>Stem girth (cm)</b>
T1	R1	39.86	40	2.5
	R2	27.92	46	2.0
	R3	28.64	37	1.9
	R4	26.90	34	1.1
	R5	28.48	30	1.9
	R6	30.75	33	1.7
T2	R1	20.77	30	1.9
	R2	23.72	39	1.8
	R3	16.96	31	1.1
	R4	31.52	27	0.8
	R5	27.87	26	1.0
	R6	35.48	29	0.9
T3	R1	37.98	37	1.8
	R2	25.41	34	2.1
	R3	17.63	42	0.9
	R4	26.77	28	1.0
	R5	18.39	24	1.2
	R6	38.44	30	1.1

Observation of growth parameters on June 25<sup>th</sup>

<b>Treatment</b>		<b>Plant height (cm)</b>	<b>Number of leaves</b>	<b>Stem girth (cm)</b>
T1	R1	49.86	80	4.5
	R2	37.92	76	3.0
	R3	38.64	77	2.9
	R4	36.90	64	3.1
	R5	28.48	70	3.9
	R6	31.75	73	2.7
T2	R1	30.77	70	2.9
	R2	33.72	69	2.8
	R3	36.96	61	2.1
	R4	41.52	57	1.8
	R5	37.87	66	1.7
	R6	35.48	59	2.9
T3	R1	47.98	77	3.8
	R2	35.41	74	2.2
	R3	37.63	72	2.9
	R4	39.77	68	3.0
	R5	38.39	64	3.2
	R6	28.44	70	2.1

### Appendix III: Method of statistical analysis of growth parameters

Analysis of variance table (Plant height (cm))

Source of variation	DF	Sum of Squares	Mean Squares	F - Calculated	Pr(>F)
Replication	53	1262	23.8	1.16	0.257
Treatment	2	4229	2114.3	102.97	<2e-16***
Residuals	106	2177	20.5		

Significant codes: 0 '\*\*\*' 0.001 '\*\*' 0.01 '\*' 0.05

Analysis of variance table (Number of leaves)

Source of variation	DF	Sum of Squares	Mean Squares	F - Calculated	Pr(>F)
Replication	53	3938	74.3	1.308	0.122
Treatment	2	6263	3131.7	55.117	<2e-16***
Residuals	106	6023	56.8		

Significant codes: 0 '\*\*\*' 0.001 '\*\*' 0.01 '\*' 0.05

Analysis of variance table (Stem girth (cm))

Source of variation	DF	Sum of Squares	Mean Squares	F - Calculated	Pr(>F)
Replication	53	15.35	0.290	1.045	0.416
Treatment	2	15.46	7.731	27.897	1.85e-10***
Residuals	106	29.38	0.277		

Significant codes: 0 '\*\*\*' 0.001 '\*\*' 0.01 '\*' 0.05

#### Appendix IV: Method of statistical analysis of yield parameters

Analysis of variance table (Number of fruits)

Source of variation	DF	Sum of Squares	Mean Squares	F - Calculated	Pr(>F)
Replication	53	7205	135.9	2.278	0.000165****
Treatment	2	2346	1172.9	19.653	5.5e-08****
Residuals	106	6326	59.7		

Significant codes: 0 '\*\*\*\*' 0.001 '\*\*' 0.01 '\*' 0.05

Analysis of variance table (Fruit length (cm))

Source of variation	DF	Sum of Squares	Mean Squares	F - Calculated	Pr(>F)
Replication	53	50.80	0.96	7.502	0.385
Treatment	2	65.79	32.9	257.463	<2e-16****
Residuals	106	13.54	0.13		

Significant codes: 0 '\*\*\*\*' 0.001 '\*\*' 0.01 '\*' 0.05

Analysis of variance table (Fruit weight (kg))

Source of variation	DF	Sum of Squares	Mean Squares	F - Calculated	Pr(>F)
Replication	53	0.03425	0.00065	0.493	0.997
Treatment	2	0.11649	0.05825	44.414	77e-15****
Residuals	106	0.13901	0.00131		

Significant codes: 0 '\*\*\*\*' 0.001 '\*\*' 0.01 '\*' 0.05

## ABSTRACT

Lack of sufficient water to grow enough crops for meeting the food demand of the increasing population is the major threat to Indian agriculture. The surface irrigation techniques cause seepage losses, erosion and water logging problems, deep percolation, salinization and runoff. To get satisfactory growth, application of right quantity of water at right time and at right place is very important and this can be accomplished only through micro irrigation techniques. Through automated drip fertigation, we can easily attain the agriculture intensification. The present study was focused on the development of GSM based automated drip fertigation system. In this study, calibration of capacitance type soil moisture sensors were carried out in laboratory for different soil types viz. laterite soil, black soil and costal alluvium soil. Field study was carried out with an Ujwala (KAU) variety of chilli crop under three treatments such as 100 percent irrigation and 100 percent fertigation with automation (T1), 100 percent irrigation and 100 percent fertigation without automation (T2) and 100 percent irrigation and 70 percent fertigation with automation (T3). The automated drip fertigation system consists of four capacitor type sensors, electronic fertilizer injection pump and fertilizer mixing device. Total yield and crop growth parameters showed better performance under 100 percent irrigation and 100 percent fertigation with automation (T1). Combination of 100 percent irrigation and 70 percent fertigation with automation (T3) also gave the good result which was on par with T1. Therefore, it could be concluded that with 30 percent less fertilizer, better performance of crop was obtained with automated drip fertigation system. It could also be shown that the right quantity of water at right time at right place is giving better performance of crop. The developed automated drip fertigation system is cost effective, portable, can perform better in field.