

**COMPUTER AIDED ANALYSIS OF 'SIT AND STAND' TYPE
COCONUT CLIMBERS FOR MECHANICAL STABILITY**

By

**POOJA V
(2016-18-001)**



**DEPARTMENT OF FARM MACHINERY AND POWER ENGINEERING
KELAPPAJI COLLEGE OF AGRICULTURAL ENGINEERING AND
TECHNOLOGY, TAVANUR – 679 573**

KERALA, INDIA

2018

**COMPUTER AIDED ANALYSIS OF 'SIT AND STAND' TYPE
COCONUT CLIMBERS FOR MECHANICAL STABILITY**

By

POOJA V

(2016-18-001)

THESIS

Submitted in partial fulfilment of the requirement for the degree

Master of Technology

In

Agricultural Engineering

(Farm Power Machinery and Energy)

Faculty of Agricultural Engineering and Technology

Kerala Agricultural University



DEPARTMENT OF FARM MACHINERY AND POWER ENGINEERING

KELAPPAJI COLLEGE OF AGRICULTURAL ENGINEERING AND

TECHNOLOGY, TAVANUR – 679 573

KERALA, INDIA

2018

DECLARATION

I, hereby declare that this thesis entitled “**COMPUTER AIDED ANALYSIS OF ‘SIT AND STAND’ TYPE COCONUT CLIMBERS FOR MECHANICAL STABILITY**” is a bonafide record of research work done by me during the course of research and the thesis has not previously formed the basis for the award to me of any degree, diploma, associateship, fellowship or other similar title, of any other University or Society.

Place: Tavanur

POOJA V

Date:

(2016-18-001)

CERTIFICATE

Certified that this thesis entitled “**COMPUTER AIDED ANALYSIS OF ‘SIT AND STAND’ TYPE COCONUT CLIMBERS FOR MECHANICAL STABILITY**” is a bonafide record of research work done independently by **Ms. Pooja V (2016-18-001)** under my guidance and supervision and that it has not previously formed the basis for the award of any degree, diploma, fellowship or associateship to her.

Place: Tavanur

Date:

Dr. Jayan, P.R

(Major Advisor, Advisory
Committee)

Professor and Head
Department of Farm Machinery and
Power Engineering
K. C. A. E. T., Tavanur

CERTIFICATE

We, the undersigned members of the advisory committee of **Ms. POOJA V (2016-18-001)** a candidate for the degree of Master of Technology in Agricultural Engineering with major in Farm Power Machinery and Energy, agree that the thesis entitled “**COMPUTER AIDED ANALYSIS OF ‘SIT AND STAND’ TYPE COCONUT CLIMBERS FOR MECHANICAL STABILITY**” may be submitted by **Ms. POOJA V** in partial fulfillment of the requirement for the degree.

Dr. JAYAN P.R
(Chairman)
Professor and HOD
Dept. of FMPE
KCAET, Tavanur

Members

Dr. Suresh Kumar P.K
(Member)
Professor,
Dept. of Agrl. Engg.
CoH, Vellanikkara

Er. Shivaji K.P
(Member)
Assistant Professor,
Dept. of FMPE
KCAET, Tavanur

Dr. Sasikala D
(Member)
Professor and HOD,
Dept. of IDE
KCAET, Tavanur

(EXTERNAL EXAMINER)

ACKNOWLEDGEMENT

I hereby wish to acknowledge my gratitude to all the researchers and practitioners who have contributed towards my understanding and thoughts. I sincerely thank all of them.

*I avail this opportunity to express my deep sense of gratitude and heartfelt indebtedness to my major advisor **Dr. Jayan P.R.**, Professor and Head, Department of Farm Machinery and Power Engineering, K.C.A.E.T, Tavanur, for his proper guidance, benevolent criticisms and encouragement during the course of research work.*

*With extreme pleasure I express my whole hearted gratitude to **Dr. Sathian K. K.**, Dean i/c, Professor and Head of the Department of Soil and Water Conservation Engineering for the infrastructure and facilities provided for my research study in his institution.*

*I offer my special thanks to **Dr. Shaji James P.**, Professor, Department of Farm Machinery and Power Engineering, K.C.A.E.T, Tavanur, for his support that he offered while carrying out the research work.*

*I wish to thank **Dr. M. S. Hajilal**, former Dean i/c, K C A E T, Tavanur for his support that he offered while carrying out the research work.*

*I offer my special thanks to, **Er. Shivaji K.P.**, Professor, Department of Farm Machinery and Power Engineering, and member of advisory committee for his constant support and guidance during my research work. I greatly indebted to **Dr. Suresh kumar P.K.**, Professor, Department of Agricultural Engineering, College of Horticulture, Vellanikkara for his support that he offered while carrying out the research work.*

*I remain thankful to **Dr. Sasikala D.**, Professor, Department of Irrigation and Drainage Engineering, K.C.A.E.T, Tavanur, a member of advisory committee for her kind co-operation and scholarly advice.*

*I express my profound gratitude to **Dr. Rajendrakumar P.K.**, Professor and Head, Department of Mechanical Engineering and **Dr. Sajith**, Professor, NIT, Calicut, for kind co-operation and scholarly advice. I greatly indebted to **Swaminathan P.**, NPD Head of Bull Agro Implements, Coimbatore, for his support and valuable suggestions.*

*Words are not enough to express my gratitude onwards **Harveer, Karthik, manoj, Shreerag**, their whole hearted co-operation, assistance, and suggestions during my project work. I would like to thank **Shiny, Sumesh**, Teaching Staffs of MES College, Kuttipuram.*

*I am in short of appropriate words to express my gratitude and love to my affectionate parents **Veeresh K., Kamala R.**, and my sister **Tejashwini** brother **Chinnu Manju** and my friend **Manohar** for their support, encouragement and prayers, ceaseless love and dedicated efforts.*

*My completion of this project could not have been accomplished without the support of my friends especially, **Pooja M.R., Ramya R., Chethan, Venkat reddy, shreedara, Shaheemath suhara, Athira Prasad, Aswathy M. S., Rasmi Janardhanan, Shahama K. Venkat sai, Uday Bhanu, Nethihagahari. Akhila.***

*My special thanks to my seniors **Veena T.**, Assistance Professor, UAS, Raichur, and **Dr. Nagesh Kumar** for their suggestions and support. My completion of this project could not have been accomplished without the support of my seniors **Jyothi Narayan, Basavaraj Patil, Pravalika, Supritha, Pooja, Anupama, Sankalpa, Ashitha G. N. and Anjali C Sunny** and my juniors **Akhila Shiny and Arya K. T.***

*I am also grateful to UG friends **Niveditha Sajjan, Shilpa Betageri, Megha Helvar, Jyothi R., Nagarathna, Jyothi S., Kousar, Preethi, Ashwini, Neeraja.***

*I express my thanks to all the **members of Library, K.C.A.E.T., Tavanur** for their ever willing help and co-operation. My heartfelt thanks to **Kerala Agricultural University** in providing the favourable circumstances for the study.*

I am thankful to each and every one who directly or indirectly helped me in doing this research.

Above all, I bow to the lotus feet of God Almighty for the grace and blessings bestowed on me.

Pooja V

TABLE OF CONTENTS

Chapter No.	Title	Page No.
	LIST OF TABLES	ii
	LIST OF FIGURES	iii
	LIST OF PLATES	iv
	SYMBOLS AND ABBREVIATIONS	vii
I	INTRODUCTION	1
II	REVIEW OF LITERATURE	3
III	MATERIALS AND METHODS	23
IV	RESULTS AND DISCUSSION	43
V	SUMMARY AND CONCLUSIONS	107
VI	REFERENCES	112
	ABSTRACT	

LIST OF TABLES

Table No.	Title	Page No.
3.1	Material properties of the coconut climbers	34
4.1	Static analysis of the top frame of KAU model	48
4.2	Factor of safety of top frame of KAU model	49
4.3	Static analysis of the bottom frame of KAU model	55
4.4	Factor of safety of bottom frame of KAU model	55
4.5	Fatigue analysis of top frame of KAU model	60
4.6	Fatigue analysis of bottom frame of KAU model	64
4.7	Static analysis of the top frame of Farmer's model	70
4.8	Factor of safety of top frame of Farmer's model	71
4.9	Static analysis of the bottom frame of Farmer's model	77
4.10	Factor of safety of bottom frame of Farmer's model	77
4.11	Fatigue analysis of top frame of Farmer's model	82
4.12	Fatigue analysis of bottom frame of Farmer's model	86
4.13	Tests to be conducted on mechanical coconut climber	91
4.14	Minimum performance standard (MPS)	95

LIST OF FIGURES

Figure No.	Title	Page No.
3.1	Top frame of KAU model	25
3.2	Bottom frame of KAU model	25
3.3	Top frame of Farmer's model	27
3.4	Bottom frame of Farmer's model	27
4.1	F.O.S of the top frame of KAU model (1.5 mm)	50
4.2	F.O.S of the bottom frame of KAU model (1.5 mm)	56
4.3	F.O.S of the top frame of Farmer's model (1.5 mm)	72
4.4	F.O.S of the bottom frame of Farmer's model (1.5 mm)	78

LIST OF PLATES

Plate No.	Title	Page No.
3.1	KAU model	24
3.2	Farmer's model	26
3.3	3D geometries of the climbers	29
3.4	Meshed models of the climbers	32
3.5	Force applied on climbers	35
3.6	Boundary conditions applied on climbers	36
4.1	Equivalent (Von-Mises) stress of the top frame of KAU model at loads of (a) 400 N, (b) 500 N, (c) 600 N, (d) 700 N, (e) 800 N, (f) 900 N and (g) 1000N	45
4.2	Equivalent elastic strain of the top frame of KAU model at loads of (a) 400 N, (b) 500 N, (c) 600 N, (d) 700 N, (e) 800 N, (f) 900 N and (g) 1000N	46
4.3	Total deformation of the top frame of KAU model at loads of (a) 400 N, (b) 500 N, (c) 600 N, (d) 700 N, (e) 800 N, (f) 900 N and (g) 1000N	47
4.4	Equivalent (Von-Mises) stress of the bottom frame of KAU model at loads of (a) 400 N, (b) 500 N, (c) 600 N, (d) 700 N, (e) 800 N, (f) 900 N and (g) 1000N	52
4.5	Equivalent elastic strain of the bottom frame of KAU model at loads of (a) 400 N, (b) 500 N, (c) 600 N, (d) 700 N, (e) 800 N, (f) 900 N and (g) 1000N	53
4.6	Total deformation of the bottom frame of KAU coconut palm climber at loads of a) 400 N, (b) 500 N, (c) 600 N, (d) 700 N. (e) 800 N, (f) 900 N and (g) 1000N	54
4.7	Fatigue life of the top frame of KAU model at loads of (a) 400 N, (b) 500 N, (c) 600 N, (d) 700 N, (e) 800 N, (f) 900 N and (g) 1000N	58
4.8	Factor of safety of the top frame of KAU model at loads of (a) 400 N, (b) 500 N, (c) 600 N, (d) 700 N, (e) 800 N, (f) 900 N and (g) 1000N	59

4.9	Fatigue life of the bottom frame of KAU model at loads of (a) 400 N, (b) 500 N, (c) 600 N, (d) 700 N, (e) 800 N, (f) 900 N and (g) 1000N	62
4.10	Factor of safety of the bottom frame of KAU model at loads of (a) 400 N, (b) 500 N, (c) 600 N, (d) 700 N, (e) 800 N, (f) 900 N and (g) 1000N	63
4.11	Equivalent (Von-Mises) stress of the top frame of Farmer's model at loads of (a) 400 N, (b) 500 N, (c) 600 N, (d) 700 N, (e) 800 N, (f) 900 N and (g) 1000N	67
4.12	Equivalent elastic strain of the top frame of Farmer's model at loads of (a) 400 N, (b) 500 N, (c) 600 N, (d) 700 N, (e) 800 N, (f) 900 N and (g) 1000N	68
4.13	Total deformation of the top frame of Farmer's model at loads of (a) 400 N, (b) 500 N, (c) 600 N, (d) 700 N, (e) 800 N, (f) 900 N and (g) 1000N	69
4.14	Equivalent (Von-Mises) stress of the bottom frame of Farmer's model at loads of (a) 400 N, (b) 500 N, (c) 600 N, (d) 700 N, (e) 800 N, (f) 900 N \ and (g) 1000N	74
4.15	Equivalent elastic strain of the bottom frame of Farmer's model at loads of (a) 400 N, (b) 500 N, (c) 600 N, (d) 700 N, (e) 800 N, (f) 900 N and (g) 1000N	75
4.16	Total deformation of the bottom frame of Farmer's model at loads of (a) 400 N, (b) 500 N, (c) 600 N, (d) 700 N, (e) 800 N, (f) 900 N and (g) 1000N	76
4.17	Fatigue life of the top frame of Farmer's model at loads of (a) 400 N, (b) 500 N, (c) 600 N, (d) 700 N, (e) 800 N, (f) 900 N and (g) 1000N	80
4.18	Factor of safety of the top frame of Farmer's model at loads of (a) 400 N, (b) 500 N, (c) 600 N, (d) 700 N, (e) 800 N, (f) 900 N and (g) 1000N	81
4.19	Fatigue life of the bottom frame of Farmer's model at loads of (a) 400 N, (b) 500 N, (c) 600 N, (d) 700 N, (e) 800 N, (f) 900 N and (g) 1000N	84
4.20	Factor of safety of the bottom frame of Farmer's at loads of (a) 400 N, (b) 500 N, (c) 600 N, (d) 700 N, (e) 800 N, (f) 900 N and (g) 1000N	85

LIST OF SYMBOLS AND ABBREVIATIONS

%	: Per cent
&	: And
/	: Per
°	: Degree
° C	: Degree Celsius
3D	: Three Dimensional
Ah	: Ampere hour
ANSYS	: Analysis System
ARS	: Agricultural Research Station
ARTS	: Artificial Rubber Tapping Machine
BPDS	: Body Part Discomfort Score
CAD	: Computer Aided Design
CAM	: Computer Aided Manufacturing
CATIA	: Computer Aided Three-dimensional Interactive Application
cm	: Centi metre
CPCRI	: Central Plantation Crop Research Institute
DC	: Direct current
DCA	: Double Cut Alternative
DES	: Department of Economic Survey
DOF	: Degree of Freedom
DRC	: Dry rubber content
<i>et al.</i>	: And others
<i>etc.</i>	: Etcetera
F.O.S	: Factor of Safety
FAO	: Food and Agriculture Organisation of the United Nations
FEA	: Finite Element Analysis
FEM	: Finite Element Method
FMTC	: Farm Machinery Testing Centre
ft	: Feet
g	: Gram
h	: Hour
ha	: Hectare
Hz	: Hertz
IGES	: Initial Graphics Exchange Specification
IS	: Indian Standards
ISO	: International Organization for Standardization
$\text{J kg}^{-1} \text{ } ^\circ \text{C}^{-1}$: Joules per kilogram per degree Celsius
KAU	: Kerala Agricultural University
KCAET	: Kelappaji College of Agricultural Engineering and Technology

kg	: Kilogram
kg m ⁻³ ° C ⁻¹	: Kilogram per meter cube degree Celsius
km ²	: Square kilometre
kN	: kilo Newton
l	: Litre
m	: Metre
min	: Minute
ml	: Milli litre
mm	: Milli metre
MPa	: Megapascal
MPS	: Minimum Performance Standards
N	: Newton
n.d	: no date
nm	: nano metre
Nmm ⁻²	: Newton per milli meter square
No.	: Number
O.E.C.D	: Organisation for Economic Co-operation and Development
ODR	: Overall Discomfort Rating
Ohm m	: ohm meter
Pa	: Pascal
ROPS	: Rollover Protection Structure
RPM	: Revolutions Per Minute
Rs.	: Rupees
s	: Second
STEP	: Standard for the Exchange of Product
TMSPCC	: Tractor Mounted and Self Propelled Coconut Climber
TNAU	: Tamil Nadu Agricultural University
U.K	: United Kingdom
USA	: United States of America
W	: Watt
W m ⁻¹ ° C ⁻¹	: Watt per meter per degree Celsius
Yr	: Year (s)

CHAPTER I

INTRODUCTION

The coconut palm (*Cocos nucifera*) is one of the most useful palms in the world. Every part of the palm is useful for human for some purpose or the other. Therefore, the coconut palm is also called as ‘Kalpavriksha’ meaning the tree of heaven. Major coconut growing states in India are Kerala, Tamilnadu, Karnataka and Andhra Pradesh. Among them Kerala is the leading state in area under cultivation of coconut. The net area under cultivation in Kerala during the year 2016-2017 was 7.70 lakh ha, production and productivity was 7448.65 Million nuts and 9664 nuts per ha (Anon., 2018). From coir industry to coconut shell artefacts; coconuts bring much economic gains to the State. Kerala is actually named after the coconut tree with “Kera” meaning coconut tree and “Alam” meaning land thus meaning “Land of Coconut Trees”.

The farming sector of Kerala state is experiencing problems like shortage of labour in peak season, lack of trained labour, high cost of available labour and high cost of production. Mechanization is considered as a remedy to the growing labour scarcity and uneconomic nature of farming. Though there is an increased initial cost in operationalizing the machinery, effective mechanization contributes towards increase in profitability by achieving timeliness in operation and increasing quality of work in the longer run. In the case of coconut cultivation, harvesting of the nuts and plant protection works are the major problems. Majority of coconuts are harvested by climbing the palm and cutting bunches down by knife. This process may seem to be simple but it is quite dangerous and time consuming. Normally skilled workers climb the palm to harvest the coconuts. Since coconut palms are very tall, any fall from the top of the palm can result in severe injury, even death. The climbers employed for climbing coconut palm suffer from musculoskeletal disorders which disable individuals at rates near or above those of traumatic, respiratory and dermatological injuries. Due to the strenuous nature of the work and

risk involved in the professional coconut climbing devices the farmers are finding difficulty to harvest the nuts.

Mechanization is the available option and a few models of climbing devices have been designed and tested. The available models of the coconut climbers include 'Chemberi', TNAU', 'KCAET (KAU)', 'Kera Suraksha (ARS)' and 'Chachos Maramkeri (Farmer's model)'. These different models are basically of either 'stand' type or 'sit and stand' type. Most of the models safety and efficiency aspects are being questioned and needs to be comparatively evaluated and modified. Almost all the available models of coconut climbers were ergonomically tested and results were reported. But no specific testing on the strength and stability were conducted and reported. The safety of the operator is important in climbing up and down the coconut palm. The available coconut palm climbers are made up of different materials and its strength and stability vary one another. There is a need of identifying the load bearing capacity of the climbers to ensure the safety of the climbing person.

When working with a coconut palm climber its construction is subjected to forces acted by the climbing person. Therefore, it is very important for the designers and agricultural machinery manufacturers to predict deformation and structural stress distributions on coconut palm climbers. Also, test codes are necessary to test any agricultural machines or equipment to issue test reports by any testing agencies in India. No specific test codes are available to test these climbers, irrespective of the models. It is a necessary tool to fix the minimum performance standards for conducting tests and to issue test reports to the manufacturers. Considering these facts, the present research work on '**Computer aided analysis of 'sit and stand' type coconut climbers for mechanical stability**' was taken up with the following specific objectives:

- To analyse the strength and stability of 'sit and stand' type coconut climbers
- To suggest optimized designs for stability of coconut climbers
- To propose the test codes for the coconut climbers

CHAPTER II

REVIEW OF LITERATURE

A brief review of work done relevant to various aspects of the present investigation was reported. Important reviews of different mechanical coconut palm climbing devices, ergonomic evaluation studies, mechanical analysis and modelling of different farm machineries using different software's, testing of farm machines etc., are presented. The reviews are categorized under the following sections.

- Palm climbing devices
- Ergonomic evaluation
- Software modelling and analysis
- Testing of farm machines

2.1 PALM CLIMBING DEVICES

Appachan, (2002) established a device to climb arecanut / coconut palms. The climber consists of metal wire ropes for clamping. By lifting the leg the user has to climb the tree. The device was simple and easy to use and it was used to climb up or down the coconut, arecanut and other similar palms. This climber was very useful for collecting the nuts and spraying pesticides. It reduces the drudgery of climber and it allows the climber to climb faster using less energy.

Joseph, (2006) developed a coconut climbing device which consists of left and right frames. Both the frames had palm gripping rubber pads and flexible encircling iron rope mounted around the palm. Each frame member had an adjustable lock for changing rope length according to the girth of the palm. An elastic strap helps the climber hold his feet inside a strap. The two frames were fixed on the palm side by side allowing the operator to lift the frames conveniently using the sliding member.

The coconut tree climbing device was developed by Jawaharlal in 2010. It consists of two similar assemblies. In this device steel rope / wires were used as grippers, adjustable to the diameter of the tree. The adjustment is made by applying the force of the user towards gravity. In this climber, there is no support for the body while climbing. It caused fatigue to the climbers or users.

In order to overcome the usability, ergonomic and safety aspects of the problems Edachari *et al.* (2011) designed a coconut tree climbing device which consisted of steel wire ropes looped around and locked for gripping of the palm. Then by the simultaneous movement of hand and foot, the user can climb up the palm. This device has a weight of 7 kg and the user can climb up to 40 m in 2-3 min. A flat foot rest and safety belts were provided. The safety belts can be adjustable as per the body posture of the climber.

Hugar *et al.* (2013) reported the design and fabrication of coconut tree climber which consists of steel wire ropes for gripping the unit to the tree. The steel wire ropes of both left and right assemblies have to be looped with the tree and have to be locked to the arrangement provided at the foot rest. As the user lift the assembly by foot the steel rope will get loosened and when he pushes back with foot it will get tightened. By this process the user can climb up the tree easily. The authors stated that the structure is able to carry a load of 100 kg. It was flexible to change the height of the equipment up to 10 cm according to the requirement of the user and it can be dismantled easily by removing the locking screw which will help in easy transport of equipment from place to place.

The areca tree climbing device was designed, developed and tested by Basavaraja *et al.* (2015). It was fabricated to climb the areca tree by applying force on two pedals alternatively. The device has two units' left hand and right hand units. Each unit consisted of a T-gripper assembly which locks the areca tree, a box-beam assembly which acts as a supporting member; pedal assembly which creates the up and downward operation of the climbing unit. Initially, the climbing unit was fitted at the base of the tree after force applied on the pedal of right hand climbing unit;

it creates the grip through the steel wire rope that was connected from T-gripper to the pedal. Then the left hand climbing unit was pulled up by using the handle that was attached to the T-gripper assembly. By this the areca tree can be climbed to a maximum height of 12 m by repeating the operation, the reverse operation was followed to descend the areca tree. About 15-20 trees can be harvested or sprayed per hour/day by using the climber.

CPCRI, Kasaragod developed an arecanut and coconut palm climbing equipment which consisted of a couples of U-shaped metal frames with rubber bushes and a foot rest. Vulcanized rubber was used to laminate the U-shaped frames in order to get a good grip with the arecanut and coconut tree trunk (Mathew and Krishnan, 2015).

A sitting type coconut palm climbing device was designed and developed by Jaikumaran *et al.* (2016). It was made of mild steel and has a weight of 9.35 kg. Its ergonomic evaluation and field performance were conducted. The total time taken to climb a 12 m height by the operator using developed climbing device was 3.16 minutes. The angle of inclination of the upper and lower metal wire rope and seat with horizontal was found to be below the safe value. The strength of wire rope used was tested for breakage and found fit. The bearing capacity of the materials and climbing device as a whole was found to be 165 kg without any failure. This device could easily be operated by any unskilled person and safety of the operator was assured during climbing.

2.2 ERNONOMICAL EVALUATION

The application of ergonomics can help in increasing the efficiency and productivity of the worker without jeopardizing their health and safety. Some of the reviews related to safety and efficiency aspects of palm climbing devices evaluated through ergonomic studies are given below.

Brian *et al.* (1998) concluded on his study of ergonomic evaluation of hand-hoes for hillside weeding and soil preparation in Honduras that the application of ergonomics, in conjunction with other disciplines, to small-farmer mechanization problems can give valuable insight into the differences between options and on their adoptability. Ergonomics is a vital element in the search for improved implement design for farmers working in marginal conditions.

Shiru and Rai (2012) revealed that operators of cassava grating machines were in various sizes and ages. The anthropometric data collected were tested statistically and the statistical results could be used for modification of existing machines for better performance, designing of new machines and sitting facilities during operation.

Thyagarajan *et al.* (2012) stated that in order to improve the relation between physical demands of the tools and worker ergonomic evaluation of farm tools was necessary who performs the work.

Kolhe *et al.* (2014) assessed the drudgery and physiological cost involved in the traditional method of tree climbing operation. For recording the heart rates the digital polar heart rate meter sensor was used. The technical assessments included the use of ODR, BPDS biomechanical models. Testing of feasibility, ease of operation; workers jeopardize safety health and efficiency of ergonomical evaluation of TMSPPC was carried out. Naieni *et al.* (2014) highlighted that ergonomists are capable of providing a safer work environment for the agricultural workers in both developing and developed countries. In addition, the results showed that it needs global cooperation of international organizations to enhance the occupational health intervention in agriculture.

2.3 SOFTWARE MODELLING AND ANALYSIS

Nowadays different mechanical analysis softwares are available to evaluate the structural behaviour of the components by adopting Finite Element Method

(FEM) analysis technology. The reviews related to structural analysis of farm machines using different FEM softwares are given below.

Jafari *et al.* (2006) performed static stress analysis of front axle of JD 955 combine using finite element method. The ANSYS version 9.0 commercial finite element package was used and considered static loads that applied on the front axle of combine. The front axle was modelled with SOLID 82 two dimensional elements, and SOLID 95 hexahedral three dimensional elements. The factor of safety was got very less and it will still reduce under cyclic loading. The results shows that the front axle of JD 955 combine was not stronger. The front axle of JD 955 combine was need to optimize the existing design to install on modified combine.

Mirehei *et al.* (2008) analysed fatigue life of connecting rod of universal tractor (U650) and its lifespan was estimated through the ANSYS software. The research conducted to know the fatigue behaviour of connecting rod under cyclic loadings to save money and time in proper manufacturing. The longevity of a connecting rod can be estimate with fully reverse loading and also can find the critical points where crack growth starts. The allowable number of load cycles using fully reverse loading was estimated 10^8 these results are useful in bring modifications in manufacturing process of connecting rod.

Kashid and Mane (2010) conducted a static and dynamic load study on existing trolley axle for redesign based on finite element analysis for reducing the weight, cost and maintains. Results of modified combine under loading of modal, static and transient analysis showed that the proposed model is suitable to install on trolley. Based on the manufacturing cost the design of axle was optimized. These results of failure analysis on the axle of trolley delivered a technical foundation to prevent future damage to the location axle.

Mollazade *et al.* (2010) conducted fatigue analysis of three shapes of subsoiler viz., C shape, L shape and sloping shape to select the best one among

them with maximum working life. Initial forces and conditions were exerted on the models after modelling of subsoilers. Models were analysed with ANSYS software. According to results lower bending moments are bearable by C shape subsoiler, hence C shape had better design and good factor of safety.

Shaari *et al.* (2010) analysed four finite element models. 3D model of connected rod was established in solidworks software. By using TET 4 and TET10 element Finite Element Model was created and compressive and tensile loads were considered. First load applied at the crank end and then restrained at the piston pin end. Secondly, load applied at the piston pin end and then restrained at the crank end. At both tension and compression the axial load was 26.7 kN. The highest von-Mises stresses was predicted at TET10 mesh of 301 MPa at a mesh size of 4 mm. Using topology optimization technique the connecting rod optimization was carried out.

Shinde and Kajale (2011) conducted a study based on finite element method of rotary tillage tool using computer aided analysis and design optimization. Structural simulation was carried out by using CAD software. The solid models of rotary tillage tool different parts were geometrically constructed. For 35 hp and 45 hp tractor boundary conditions and actual field performance rating parameters were set in the software. The information of estimated forces performing on soil tool interface were taken as loading condition input for software. The work carried out to know the effect of change in dimensions of the proposed working resulted in identifying sufficient tolerance in changing the dimensions of side gear box and rotavator frame sections to raise the weight of blade for a reliable strength and to remove excess weight in a solid section.

Tarighi *et al.* (2011) conducted design analysis of front axle housing of MT250D Mitsubishi tractor. Modelling of an housing was done by using Solidworks 10.0. In order to use finite element method for static and dynamic analysis, Cosmos Works Software (Version 2010) was used. Finite element analysis results showed that the maximum stress of 238.84MPa was applied on the upper

housing. According to Von- Mises theory, the value of maximum applied stress and allowable stress, the safety factor of 1.05 was obtained which was less than the required value. The first four natural frequencies of housing were found out as 678.54, 720.29, 908.78 and 1877 Hz, respectively. The obtained factor of safety was very low and obviously this value decreased under dynamic loading conditions of field operation. The present study clearly indicated that the front axle housing of MT250D Mitsubishi tractor was not strong enough to be mounted on a tractor. There was a need to optimize the existing design of the front axle housing.

Yilmaz *et al.* (2011) conducted study on the analysis of stresses on the transport chassis of turbo atomiser by finite element method. By using solidworks 3D parametric design software the chassis was modelled. For static loading condition stress analysis was performed with three forces. Meshed structure of the chassis had a total 9924 elements and 17471 nodes. Results showed that 1584.9 MPa stress was observed on the chassis for a forces of 40000 N. On the contact point of the tractor with machine the maximum displacement of 133.045 was obtained. At a force of 10000 N, safety factor was found > 1 but safety factor less than one was found for both 20000 and 40000 N. The study concluded that the chassis should be manufactured by higher yield stress material for forces of 20000 and 40000 N.

Bansal and Kumar (2012) conducted study on trolley axle for redesign at static load conditions. By using ANSYS 12.0 software CAD model was prepared. After analysis 11.5 per cent reduction of weight of axle was done to improve cross section that is 40 x 80 mm. optimization of the axle was carried out based on manufacturing cost. In ANSYS 12.0 3D models of the existing axle and proposed axle geometry was generated and mesh was generated. Then load points were defined and results of stress, strain and deformation were generated automatically in solution phase.

Bansal, R (2013) performed connecting rod structural analysis. In CATIA V5R18 connecting rod three dimensional model was made and saved in IGES

format. Afterwards in ANSYS 13.0 model was imported and connecting rod material properties were assigned. The results shows that at the centre of big end and small end bearings with inner fibre surface maximum deformation was obtained.

Bharti *et al.* (2013) carried out FEA of I-section connecting rod. FEA was the most appreciable technique for analysing the complex machine component subjected to various forces and stresses. A parametric model of connecting rod was modelled using PRO-E 4.0 software and ANSYS 13.0 was used for the FEA. By analysing the steel connecting rod stress was investigated and maximum stress was found out. The weight optimization was done from the results of the analysis.

Hubalovsky (2013) conducted study on static analysis of Frame of Elevator Cab to know the Mechanical Properties. The simulation model of device was created with static mechanical properties. The example of process of creation of mathematical model was revealed on calculation of deviation of the frame of elevator cab. Based on bending theory of the beam the mathematical model was established. The validation of the model was done by finite element method in solidworks software.

Manasa and Reddy (2013) conducted study on static analysis of trolley axle of tractor. By CATIA-V5 the axle solid model was developed and by using ANSYS work bench the analysis was done. The analysis was made for circular section by replacing rectangular cross section. Von-misses stress, equivalent elastic strain, maximum shear stress and total deformation were found in static analysis. As per the results the weight of the circular axle was reduced to 20 percent as compared to rectangular section axle.

Ssomad *et al.* (2013) conducted a study on development of Dioscorea hispida tuber harvesting hand tool. The Computer Aided Design (CAD) environment system was selected for modelling and simulation. The estimated force acting on the hand tool from field experiments was used for simulation of model. By using

solid works simulation program the minimum or maximum displacement and stress results obtained by simulating different material of hand tool by uploading the material characteristic. In order to select the strongest material for the fabrication the information obtained from the simulation analysis was used. Three materials viz., aluminium alloy, plain carbon steel and cast carbon steel which were commonly available in market were chosen. The simulation analysis conducted on hand tool harvester enabled the designer to select strongest material for the construction stage. It helped in selecting the lighter and stronger material for designing and fabrication.

Bhaskar *et al.* (2014) carried out the geometric modelling of the various components of the chassis in part mode as 3D models using Pro/ENGINEER 2001 software. The section properties, viz., cross-sectional area details of the 3D modelled parts were estimated using the modelling software. The above properties had been used as input while performing the finite element analysis using ANSYS 7.1 software. The finite element model of the chassis was created using ANSYS 7.1 package. Static analysis was done for vehicle on a plain road and bump conditions. The model was subjected to static analysis for all the conditions specified. The stress and deflection plots were analysed. Maximum deflection of chassis was found to be 0.2mm and maximum stress was found to be 16.6MPa. The design stress for the alloy steel material of the chassis was made at 500 MPa. The factor of safety was estimated as 30.12.

Dey *et al.* (2014) studied front axle beam transient, static and modal analysis. In Pro-E WildFire 5.0 software the geometry of axle was created which was imported to ANSYS 14.5. To assess the strength and capability of the product a fine congruence finite element model was generated using the software to survive against all vibrations and forces. Using tetrahedral elements SOLID45 and SOLID92 the current model was meshed available in ANSYS. The 38998 elements and 69009 nodes were contained by model and correct boundary conditions were defined. 0.28897 mm maximum deformation, 319.46 MPa maximum Von Mises stress,

1.8789×10^{-3} maximum strain and 136 MPa maximum shear stress were obtained from the analysis.

Gavali and Kulkarni (2014) conducted study on Finite Element Method development of rotary weeder blades. In CATIA the CAD Model prepared and in Hyperworks it was imported. Using 3D meshing the model was divided into elements. Triangular 2D and 3D elements were created using tetra-type volume meshing. Models of blade were applied by materials, properties and loads. The results revealed that the lowest displacement and stresses of analysis observed in L shaped geometry blade configuration. The blade geometry perform well in fields than others.

Rajashekar *et al.* (2014) conducted study on, simulation, modelling analysis, testing and fabrication of low cost 3 row weeder. By using CATIA software the structure and mechanical parts of weeder were designed and its 3D modelling, interference checking, assembly, kinematics simulation, and 2D engineering drawing conversion were done. Further in (.stp) format 3D cad model was saved and in ANSYS work bench environment it is imported. The multibody dynamics simulation and Finite element analysis were done in ANSYS for safe design. As per the results design and development period and cost of design reduced by using simulation based design technology.

Da silva *et al.* (2014) conducted a study on static simulation of coffee harvester by using finite element method to get the results of displacements and stresses. Coffee harvester main parts were analysed they were main frame, front and rear end, body right and left sides, coffee reservoir, main beam, fuel tank and wheels. 2 different design concepts viz. rear wheels coffee harvester machine structure with aligned and misaligned and results were equated. It was detected that rear wheels aligned model showed higher maximum displacement than rear wheels misaligned design model. In the rear wheels aligned lower stress was found, in most structural components it was detected that average stresses for the aligned wheels design were higher. The results shows that rear wheels misaligned was the best

design concept hence rear wheels misaligned coffee harvester and confirmed that no fail during operation.

Yegul *et al.* (2014) investigated total deformation and equivalent stress of two different types of harrows and three different types of tines. The models were generated in the solidworks software and the analysis part carried out in ANSYS workbench. The finite element analysis was set up in 3D, static and linear material property assumption. In the ANSYS workbench the stainless steel material property for all the models were assigned and the boundary conditions were applied. According to the results of the analysis the maximum equivalent stress and maximum total deformation were found 34.374 MPa and 99982 mm respectively. The results motivated that all the models can be used in tillage operations.

Chennuri *et al.* (2015) conducted a study to assess the stresses and deflections in the ROPS of different cross-sections under different types of load conditions and compared the results to find out the most suitable type of cross-section. The ROPS was modelled by SolidWorks 2013 and analysed using ANSYS 14.0. Alloy steel was used as ROPS material. Three types of loadings were investigated viz., rear loading, side loading, and vertical loading. Four types of cross-sections examined viz., square, circular, hollow square and hollow circular. This particular test was carried with accordance to SAE J2194 standard.

Dadhich *et al.* (2015) conducted a study on fatigue analysis of a centrifugal fan. The centrifugal fan modelling was done in Catia V5R20 software and meshing was done in ANSYS 12.0. Meshing consists tetrahedral elements and having 129842 elements and 226376 nodes. The structural analysis carried out in ANSYS 12.0. The structural analysis was included the fatigue testing of the fan. In this study the contours of deformation, equivalent stress, fatigue life, fatigue damage and factor of safety were plotted by using ANSYS software. The fatigue testing was carried out at 705 RPM. Gerber mean stress theory model was taken for fatigue analysis. High cycle fatigue analysis with 10^6 cycle was done. Constant amplitude fully reversed load was applied. The results of fatigue analysis indicated that the

contours of the fan will not run safely for it's designed of 10^6 cycles on the operating conditions.

Makange *et al.* (2015) conducted study on Finite Element Method (FEM) analysis of nine tine cultivator. Cultivator is a one of the secondary tillage implement used by most of the farmers. The analysis was conducted to find out failure in the shovel of the cultivator due to different loading condition at different speed in medium black soil. Locally manufactured cultivators get failed after one session of use at different points. By using CREO-parametric software tine CAD model was developed. Stress were determined by FEM analysis by using ANSYS software. The draft force exerted on the single tine was found out by field experiments taken as loading condition. After creating the mesh structure of the tine, total nodes of 1294 and total elements of 569 were obtained. The result of analysis concluded that the total deformation the maximum and minimum principal stress are respectively as 0.076953 mm, 5.1726 and 0.20944 MPa. Maximum stress was less than the yield point, which showed that deformation does not cause failure.

Malon *et al.* (2015) studied rodenticide bait implement testing using FEA, considering a range of loads generated on most commonly used furrow openers in agricultural implements. By analysing the effects of forward speed and application depth the prototype was tested in the field on the mechanical behaviour of the implement structure. In the design phase the FEM was used and a prototype was manufactured. By using strain gauges the structural strains on the prototype chassis under working conditions were tested to validate the design phase. By analysing the information obtained from the strain gauges the prototype was validated successfully. At the most critical load, a safety coefficient of 1.9 was obtained which was indicated by Von Mises stresses. The linearity in effects of the application depth on the strains was such that the strain increased with depth. In contrast, regardless of variation in the forward speed the strains remained roughly constant.

Manivelprabhu *et al.* (2015) conducted a study on design modification and structural analysis of rotavator blade by using HyperWorks 12.0. The structural analysis was carried out to check the stress distribution and displacement in the modified new blades. Both the existing and new blade were modelled and analysed using FEM. The three dimensional model of new and existing blades were generated using CATIA R20. The solid models were imported to Hyperworks to carry out the structural analysis. The tetra mesh was generated by using Hypermesh 12.0. The maximum displacement of existing blade was 1.7mm and for the new rotavator blade displacement was 1.372mm. The Von Mises stress of existing blade was $2.692 \times 10^2 \text{ N/mm}^2$ and new blade the stress value was $2.483 \times 10^2 \text{ Nmm}^{-2}$.

Rahul *et al.* (2015) conducted a study on design a coconut tree climbing device for the use of farmers and residents. Due to the constant cylindrical structure and single stem it was very difficult to climb on coconut tree manually. Using Solid Works 14.0 the design of the prototype was done and by ANSYS 14.5 static load analysis was carried out. Suitable material was chosen and fabrication of the prototype was successfully done using static load analysis and trial and error method. The analysis showed that a maximum stress of $1.4815 \times 10 \text{ Pa}$ at the region where the links were attached to the actuator was obtained and was safe. Suitable changes were made to the prototype by testing the prototype under real life conditions. The final prototype thus obtained was found to be successful and fully operational.

Syedabadi (2015) studied the Finite Element Analysis of Lift Arm of a MF-285 tractor three-point hitch. The finite element method was used to estimate the stress distribution and factor of safety of lift arm in SolidWorks software. The FEA results showed that the maximum values of the Von Mises equivalent stress for both examined load cases were respectively as 79 and 367 Mpa for lifting a usual plow of 500 kg and maximum hydraulic lifting capacity of 2230 kg. The lift arm was safe enough for lifting of a usual plow but it failed when the three-point hitch works with maximum hydraulic lifting capacity. It was recommended to revise the design

and construction process of the lift arm or limit the lifting capacity to 1430 kg weight.

Sharma and Bhargava (2015) conducted a study on stress, strain, deformation and fatigue analysis of two different kinds of Chisel Plow for an agriculture use. One is Old Chisel Plow and another is New Generation Chisel Plow. Design optimization of tillage tools was achieved by application of CAD/CAM which was based on the simulation method and Finite Element Method. The various components of the tillage tools were simulated with the help of actual field performance rating parameters which were prepared by solid models along with actual boundary conditions. The planned work outcomes of sufficient tolerance in varying the working parameters of Chisel Plow sections for ejecting the extra weight in a solid section and also to increase the weight of plow for a consistent strength.

Armin *et al.* (2016) conducted a study on finite element (FE) investigation of soil–blade interaction of curved-shape blades. Studied modeling and behavior of a blade with different rake angles and different curvatures that moves through a block of soil. In the FE general 3D model both soil and blade were represented by the hexahedral elements SOLID45 from the ANSYS library of elements, which had 8 nodes and 3 degree of freedoms (DOF) at each node. The soil-blade connection is modelled by the contact elements CONTACT173 and TARGET170 placed along the separation surface. The proposed model verified as simulation results from FEA had good correlation with analytical soil mechanics findings for straight blades.

Balwani and Gulhane (2016) studied FEM analysis of two furrows reversible plough. A proper modelling was done by Creo 3.0 software. Then by using ANSYS 11.0 software FEM analysis was done to determine the different types of stresses and deformation developed. It was been found out that whenever there was a sudden impact on the plough the shaft bend and thus for efficient working the shaft was redesigned to withstand the different forces along with static and dynamic load.

Burande and Kazi (2016) carried out simulations of alloy wheel for specific design through realistic loading conditions. Skoda Octiva passenger car alloy wheel was used for simulation. In this study, stress distribution of alloy wheel was evaluated by using finite element analysis. S-N curve was generated for aluminium alloy material. The radial fatigue test was carried on specimen according to industrial standards. The wheel was checked for fatigue life cycle and improvement in the material. An attempt has been made by conducting study to suggest a suitable safety for reliable fatigue life prediction. The results of equivalent stress, factor of safety and fatigue life of both grades aluminium alloy showed that 7075- T6 grade was the best suitable material for alloy wheel.

Celik *et al.* (2016) conducted a study on design and structural optimisation of a tractor mounted telescopic boom crane. Every single component of the crane was modelled using the SolidWorks 3D parametric solid modelling design software. FEA was set up considering static loading, bonded contact, and linear and isotropic material model assumptions. The analysis was conducted using SolidWorks simulation commercial finite element code. Meshing operations were carried out using the meshing functions of the FE code. In the meshed structure, 10 nodes second-order parabolic solid element type was used, and a total of 585,904 nodes and a total of 331,344 elements were obtained. The FE model had a total of 1,740,303 degree of freedom. The simulation output extracted the maximum displacement of 20.544 mm at the loading point of the boom in the direction of vertical loading. The simulation outputs indicated no significant failure on the crane components and it was concluded that the crane design was durable enough under the defined maximum loading conditions.

Galat *et al.* (2016) studied failure and analysis of agriculture nine tyne cultivator in different soil conditions. For analyse tyne mechanism using FEM, firstly a proper CAD model has been developed using Pro/E cad software. Then by using ANSYS software FEM analysis was done to determine the stresses. Tyne had a number of stresses but concluded that shear stress was maximum as compared to

other stress. The better solution to minimize the shear stress was to improve life and efficiency of tyne.

Ghumadwar and Bankar (2016) conducted a study on design of the crop cutting machine using KERO drawing software. The force analysis was made on the roller cutter blade by using ANSYS 14.0 software. The static and dynamic analysis on the rolling cutting blade was done. The force generated for the static analysis Von Misses stress was 1.2466×10^7 Pa and the deformation of the blade was 2.7041×10^{-4} m. it was formulated that the design of cutting blade was safe.

Jakasania *et al.* (2016) conducted parabolic type subsoiler finite element analysis using ANSYS and Creo software. By SOLID 45 3D elements the model was meshed. In parabolic type subsoiler, the 9475 nodes and 4565 elements are the size of finite models. In the shank of holes boundary conditions were provided. Because it was facility to attach shank to the frame of machine. In all degree of freedom all of these conditions were constrained so the moments of shanks get restrict in any directions. The maximum draft force of about 6994 N was applied on the share. Total deformation, equivalent stress, principal stress, shear stress and factor of safety were the parameters selected for static analysis of the subsoiler.

Ren *et al.* (2016) analysed SX360 Dump Trucks frame bending strength and deformation. Parametric finite element model of SX360 dump trucks frame was built in ABAQUS software. The frame was made up of Q235 steel material having density 7.85×10^{-6} kg mm⁻³. After assigning the material property for the 3 dimensional model, divided the model into 19591 cells and 41440 nodes. The load and boundary conditions applied were, about 5000N force in the negative direction of the Y-axis and the frame contact was considered as rigid. At contact points of the frame bottom surface with supporting parts the maximum operating stress was found by static analysis.

Sachin and Rakesh (2016) conducted a study on fatigue life analysis of disc wheel. Solidworks software was used for the analysis. The static analysis carried

out in the ANSYS. Meshing was done in the Hyper Mesh software. The fatigue life estimation was carried out in NCODE software where the results of static structural analysis and transient structure analysis in rst files generated by ANSYS was an input. The S-N approach was carried out to validate the life estimated by NCODE. The life was calculated from the line with the NCODE software. By S-N curve the fatigue life calculated with respect to stress vs number of cycles. The results showed that the fatigue crack initiation regions on the wheel rim were subjected to stress concentration. Considering these results minimum fatigue life was found out as 2.334×10^6 cycles for current design.

Shafi *et al.* (2016) conducted a study on dynamic and fatigue analysis on tillage equipment. 3D modelling of tillage equipment consisted of several parts. All the parts of tillage equipment were modelled in NX-CAD software. The body was imported from Unigraphics to ANSYS 11.0 in the form of “Parasolid” format to do the further analysis. First the dynamic analysis was carried out and the modelling of modified tillage equipment was done. Fatigue analysis was done on the modified tillage assembly to determine the life of the tillage assembly for operating loads. To determine the life of the tillage equipment assembly Goodman’s diagram was plotted. To plot the Goodman’s diagram, the minimum principal stress and maximum principal stress values were determined; along with parameters. Ultimate strength and endurance limit of the material were also determined. The results concluded that the tillage equipment assembly had infinite life and the total life of component (in cycles) was 9860584.44 cycles.

Abdulkarim *et al.* (2017) conducted a study on analysis of low cost mini combine harvester chassis and hitch. Solidworks Finite Element Analysis (FEA) software was employed in carrying out both static and fatigue analysis of a low-cost mini combine harvester chassis and hitch design. The results were compared and contrasted with appreciable improvements on available existing data. The stresses, displacements and strains on the chassis were significantly low with factors of safety of 2.48 and 2.80 for the chassis and hitch assembly.

Bishwal and Thomas (2017) conducted a study on design and stress analysis of cultivator tillage design. The model was created by creo parametric 2.0 design software, the analysis was carried out using FEA ansys 16.2. The exact geometry dimensions of cultivator tillage was taken and all boundary conditions were applied while analysing. The results showed that the 8 mm diameter hole in the cultivator tyne was the best for configured cultivator design.

Chen *et al.* (2017) conducted static structural simulations of non-rotor UAVs for static and fatigue analysis. The relative analysis of titanium alloy and aluminium alloy structures of non-rotor UAVs were carried out. PTC Creo was used to build geometric model. Then the model was imported into ANSYS for structural static and fatigue analyses. With load bearing being the vehicle's objective, fatigue intensity verification, structural factor of safety calculations, and finite element analyses were carried out to obtain the total deformation and equivalent stresses. These parameters were used to analyse fatigue lifetimes, safety factors and fatigue lifetimes.

Jahanbakhshi *et al.* (2017) conducted the stress analysis of crossbar of moldboard plough pulled by Massey Ferguson 285 and 299 Tractors. The 3D model was drawn in Solidworks Software and transferred it to ANSYS Software. The constraints, boundary conditions and loads were applied on the model. Then the static analyses were done for the model. The results of static analysis showed that the maximum static stresses based on Von Mises criteria occurred at the junction between the left and right pins with crossbar. The stress values based on Massey Ferguson 285 Tractor were 126 and 83.7 MPa, respectively, and based on Massey Ferguson 299 Tractor were 136 and 90.6 MPa, respectively. The obtained safety factors for the left and right pins were respectively as 1.57 and 2.36. These results showed a higher probability of failure at the left pin junction.

Jakasania *et al.* (2017) conducted a study on the static analysis of the inclined type subsoiler. By using creo software the inclined type subsoiler solid model was created. Static structural analysis was carried out by using ANSYS software. As per

the local manufacture catalogue the dimensions of the inclined type subsoiler was taken. Maximum draft force was exerted on the inclined type subsoiler while operating in the field which was taken as loading condition. The results of simulation at the end of the share showed that the maximum deformation was observed as 2.74mm. A maximum equivalent (von Mises) stress of 280.71Mpa was observed at the clamp. A maximum principle stress of 283.30 Mpa and maximum shear stress of 46.24 Mpa were found in subsoiler. A factor of safety of 1.25 was found and it was observed that factor of safety was very low so to optimise the required design.

Tripathi and Crasta (2017) evaluated the fatigue behaviour of connecting rod made of austempered ductile Iron. The parametric model of connecting rod was modeled using CATIA V5 R20 which was then imported to ANSYS 15.0, a Finite Element Analysis tool. Due to cyclic loading and presence of stress concentrations at the critical areas, fatigue become the primary cause of failure of connecting rods. Stress life theory was used to carry out the fatigue analysis. The focus of fatigue in ANSYS is to provide useful information to the design engineer when fatigue failure may be a concern.

Sadiq *et al.* (n.d) studied structural analysis and performance evaluation of multipurpose agricultural equipment, which performs major agricultural operations like goods carrying, pesticide spraying, laddering, inter cultivating and digging operations of sandy loam deep soils, to increase the efficiency and reduce the production and handling cost. The analysis was first followed by a solid works model followed by meshing using hyper mesh software and analysis by ansys software. It was found that the stresses produced was 150Mpa and deformation was 20 mm under 800 kg load. It was proved safe when compared to allowable stresses of material.

2.4 TESTING OF FARM MACHINES

Ahaneku *et al.* (n.d) evaluated the performance of three different ranges of Mahindra tractors. The parameters evaluated were travel reduction (wheel slippage), draught force, speed of operation, drawbar power, volume of soil disturbed, fuel consumption, effective field capacity, theoretical field capacity, field efficiency, and average width and depth of cut during ploughing and harrowing operations. The soil physical and dynamic properties were also measured.

Al-Suhaibani *et al.* (2010) states that field machines contribute a major portion of the total cost of crop production. Proper selection and matching of farm machinery is essential in order to reduce the cost of crop production. Performance data for tractors and implements are, therefore, essential for farm machinery operators and manufacturers alike.

Faleye *et al.* (2014) concluded that the results generated from standard testing have to be used to guide concerned agricultural equipment industry in the country, assist in improving the quality of locally produced equipment, the selective importation of equipment, and in farmers' purchase and use of agricultural equipment. Nigerian agricultural productivity can be significantly enhanced with mechanization specifically designed to perform in local agro-ecological conditions. This would require modern testing equipment, efficient organizational structures and research-based knowledge to ensure efficiency and impact in improving agricultural mechanization in the country.

Kumar *et al.* (2017) evaluated the performance of four different sized tractor -implement combination .The parameters evaluated were travel reduction (wheel slippage), draft, speed of operation, drawbar power, volume of soil disturbed, fuel consumption, field efficiency and soil pulverization.

CHAPTER III

MATERIALS AND METHODS

Though many types of coconut palm climbers are available, the farmers are confused in choosing the best among all. The safety of the operator is yet another important factor to be considered in climbing up and down the coconut palm using mechanical climbers. The available coconut palm climbers are made up of different materials and its strength and stability vary one another. There is a need of identifying the load bearing capacity of the climbers to ensure the safety of the climbing person. The strength and stability of two existing models viz. KAU model and Farmer's model were analysed using ANSYS 15.0 software. Hence the study is also envisaged to suggest design modifications of the selected models. In order to study the performance of the climbers standard test codes are necessary. As there is no specified test codes available for manually operated mechanical tree climbers, a draft test code with Minimum Performance Standard (MPS) was also prepared under this study.

3.1 KAU MODEL

KAU model (Plate 3.1) is a modified version of the TNAU coconut palm climber. It consists of top and bottom frames fitted with adjustable 'U' frame members. The top frame is intended for comfort seating of the operator and bottom frame is attached with an actuating mechanism for climbing up and down the palm.



Plate 3.1 KAU model

The top frame has to bear an average weight of the worker of about 60-70 kg without any bending due to cantilever action. Galvanized iron was selected as the material for its fabrication. The bottom frame is for placing the legs of the operator and for actuating the upward and downward motion. While climbing, both frames (top and bottom) are moved upward alternatively by means of combined actions of hand and leg (knee and toe action) together. These actions will just reversed when climbing down. As the bottom frame is only for facilitating these supportive actions, aluminium alloy is selected as the material for its fabrication, which in turn helps to reduce the weight of the unit. The total weight of the climber including top and bottom frame is 9.50 kg. The thickness of the parts are 1.5 mm. Both the frames are made with square pipe of 20 mm × 20 mm cross section. Safety lock pins are provided for attaching the ‘U’ frames with main units which reduce the time for fitting or removing of the climber. Rubber bushes are provided in both frames as gripping material. The lifting of bottom frame with toes was a tough task for the users and induce strain to the legs. Specially designed foot wears were provided on the bottom frame. The palm gripping section of the top frame was made of ‘U’ shape with an inclination to the horizontal. Hence while climbing; the top frame will remain parallel to the horizontal and hence ensure more stability to the climber. ‘U’ frame is also provided to the bottom frame with an inclination to the horizontal

for giving more safety to the operator. Sagging type rexin seat was provided on the upper frame which increased the comfort and safety of the operator.

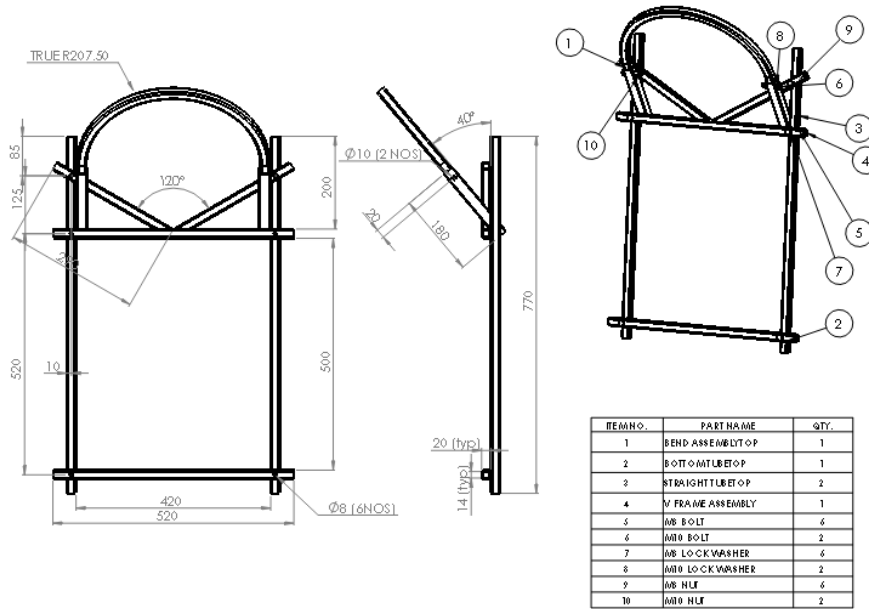

(All dimensions are in mm)

Fig. 3.1 Top frame of KAU model

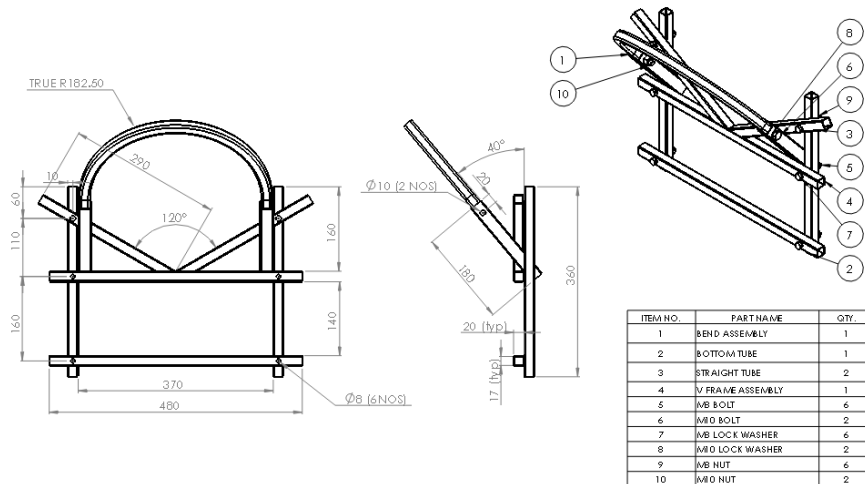

(All dimensions are in mm)

Fig. 3.2 Bottom frame of KAU model

3.2 FARMER'S MODEL

Farmer's model is a climber (Plate 3.2) consists of top and bottom frames fitted with adjustable wire ropes. The top frame is intended for comfort seating of the operator and the bottom frame is to support the foot. When person sit on the top frame the bottom frame become loose and it is taken to up or down by leg, when person stands on the bottom frame the top frame become loose and it can take up or down the palm by hand.

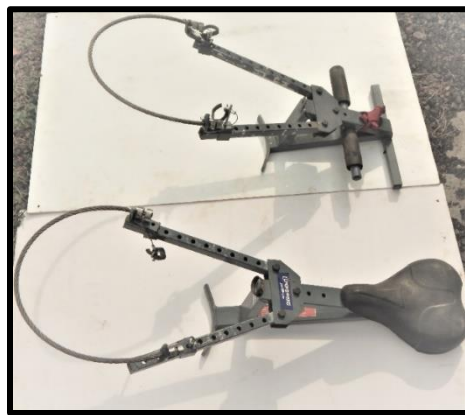
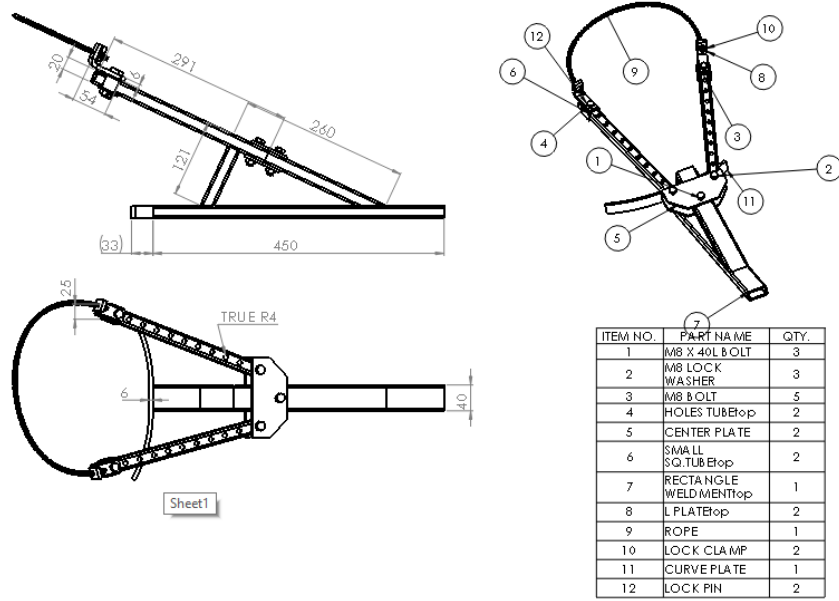

Plate 3.2 Farmer's model

While climbing, both frames move upward alternately by means of combined actions of hand and leg, these actions will be just reversed while climbing down. Both top and bottom frames should carry the weight of about 40 to 100 kg depending upon the weight of the operator. The structural steel is used for its fabrication. Total weight of this climber including top and bottom frames is 4.95 kg. Safety lock pins were provided for attaching wire ropes with the main units which reduces the time for fitting or removing of the climber. Rubber bushes were provided for foot rest and foot holder as cushioning material.



(All dimensions are in mm)

Fig. 3.3 Top frame of Farmer's model

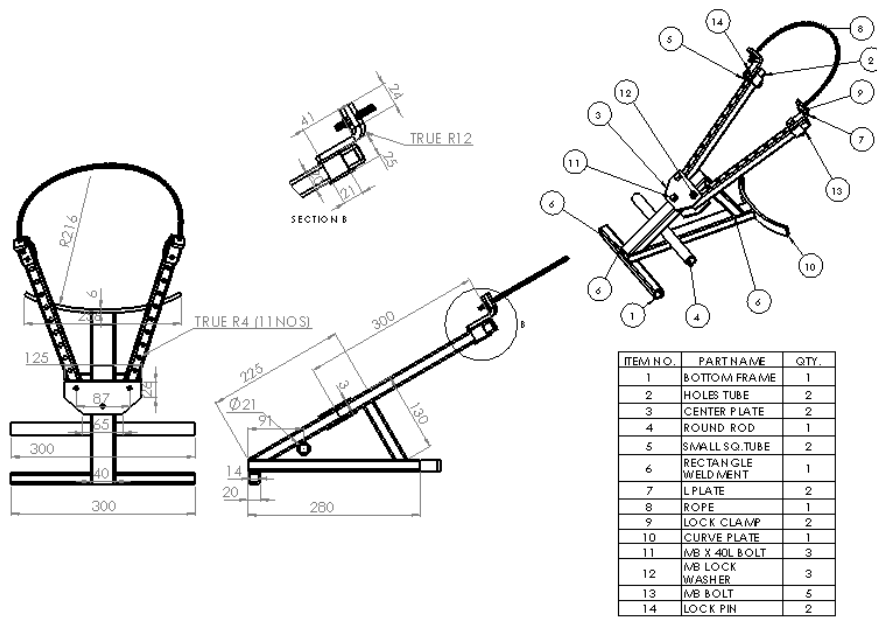

(All dimensions are in mm)

Fig. 3.4 Bottom frame of Farmer's model

3.3 MODELLING

Modelling is the process of developing a mathematical representation of any surface of an object in three dimensions using a specialised software. Three dimensional (3D) modelling software is a class of 3D computer graphics software used to produce 3D models. Some of the 3D modelling Softwares are Solidworks, Auto CAD, Autodesk Inventor, CATIA etc. The 3D modelling of KAU and Farmer's models of climbers were carried out in Solidworks 13.0 software. Solidworks is an easy software which make use of modular parametric designs. In Solidworks, 3D models of each part can be designed and assembled together easily and interference between components can be checked conveniently (Liao *et al*, 2011). Solidworks is the first 3D CAD software developed on windows operating system. Due to its powerful functions it become easy to learn and use the characteristics and widely applied in mechanical designing. Also this Software is suitable for product development as it can shorten the product design cycle, improve design quality and reduce the cost involved. Hence it become one of the main stream software in mechanical design and modelling (Shahu 2017). In order to generate any 3D model it is necessary to get the proper dimensions of each components. The dimensions of various parts of KAU and Farmer's models were taken by direct measurement available in the Farm Machinery Testing Centre (FMTC), KCAET, Tavanur. After measuring all the dimensions of KAU and Farmer's models, the 3D models of the individual parts were created using Solidworks 15.0 software. Then the assembly of each component of the top and bottom frames climbers were created in the same software. These 3D models were then saved in step file format. The file was then imported to the ANSYS 15.0 software for the static and fatigue analysis. The generated 3D models of KAU and Farmer's models are given below.

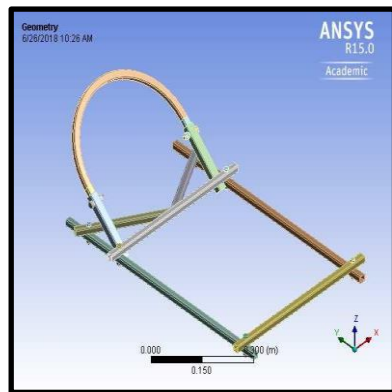

(Top frame)

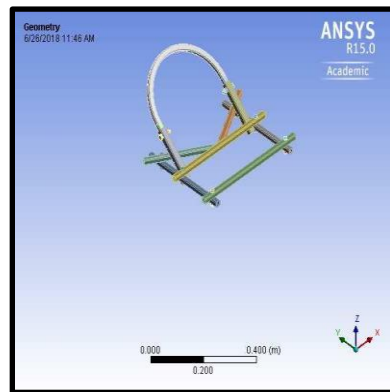

(Bottom frame)

(a) KAU model

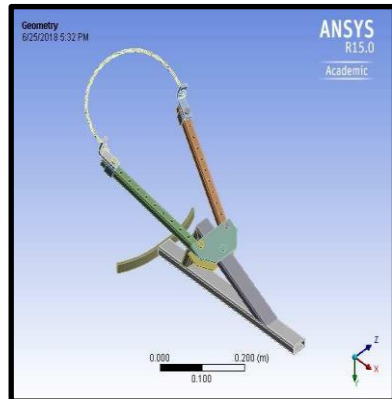

(Top frame)

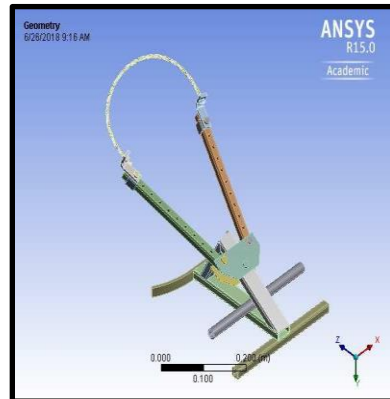

(Bottom frame)

(b) Farmer's model

Plate 3.3 3D geometries of the climbers

3.4 ANALYSIS

Nowadays the numerical methods of structural analysis are getting popular due to its simplicity. The most commonly used numerical approximation method in mechanical structural analysis is the Finite Element Method. The analysis of KAU and Farmer's models were carried out to find the effects of loads on structural and

mechanical failures. The analysis results are helpful in determining whether the structure is fit for use. Structural analysis is thus a key part of the engineering design of structures. In order to analyse the performance of any structures or components, it is necessary to know the informations about the loads, geometry, boundary conditions and material properties.

The finite element method (FEM) is a numerical technique used to perform finite element analysis (FEA) of any given physical phenomenon. It is also a computerized method for predicting how a product reacts to acting forces, vibration, heat, fluid flow, and other physical effects. Finite element analysis shows whether a product will break, wear out, or work the way it was designed. Engineers use it to reduce the number of physical prototypes and experiments and optimize components in their design phase to develop better products, faster. Some of the software packages that implement the finite element method for solving partial differential equations are abaqus, HyperMesh, Autodesk Simulation, ANSYS, CosmosWorks etc. In mechanical analysis of KAU and Farmer's models the ANSYS 15.0 software was used. The analysis was conducted at the computer lab attached to Dept. of Mechanical Engineering, NIT, Kzhikode.

ANSYS is a general purpose software package based on the finite element analysis. The software creates simulated computer models of structures, electronics, or machine components to simulate strength, toughness, elasticity, temperature distribution, electromagnetism, fluid flow, and other attributes. ANSYS is used to determine how a product will function with different specifications, without building test products or conducting crash tests. For example, ANSYS software may simulate how a bridge will hold up after years of traffic. Most ANSYS simulations are performed using the ANSYS Workbench software, which is one of the company's main products. Typically ANSYS users break down larger structures into small components that are each modeled and tested individually. A user may start by defining the dimensions of an object, and then adding weight, pressure, temperature and other physical properties. Finally, the ANSYS software simulates

and analyses movement, fatigue, fractures, fluid flow, temperature distribution, electromagnetic efficiency and other effects over time (Makange *et al.*, 2015).

Also this software enables to simulate tests or working conditions, enables to test in virtual environment before manufacturing prototypes of products. Furthermore, determining and improving weak points, computing life and foreseeing probable problems are possible by 3D simulations in virtual environment. ANSYS can work integrated with other used engineering software on desktop by adding CAD and FEA connection modules. ANSYS can import CAD data and also enables to build a geometry with its preprocessing abilities. Similarly in the same preprocessor, finite element model which is required for computation is generated. After defining loadings and carrying out analyses, results can be viewed as numerical and graphical. ANSYS can carry out advanced engineering analyses quickly, safely and practically by its variety of contact algorithms, time based loading features and nonlinear material models. ANSYS Workbench is a platform which integrate simulation technologies and parametric CAD systems with unique automation and performance.

3.4.1 Procedure

The ANSYS Finite Element Method analysis consists of three steps, they are preprocessing, solution and post processing. These steps were followed in the mechanical analysis of KAU and Farmer's models using ANSYS 15.0 software.

3.4.1.1 Preprocessing

Preprocessing involves meshing, applying boundary conditions and material properties. The meshing is done by taking 3D models of the parts of climbers and then breaking them into thousands of tiny pieces that are of regular shape, say a cube or pyramid, through a process called meshing. Each tiny piece is called an element (hence 'Finite Element' analysis) and the corners of the elements are called nodes. The structure is split into small elements because there is no mathematical

formula to calculate the stress and displacements in a complex shape. But there are formulae to calculate stress and displacements in a cube or pyramid when load is applied to it. So the whole premise of FEA is to take a complex shape and break it down into tiny, regular shaped elements for which stress and strain can be calculated. Then add all those results together to determine the overall stress and strain within the part and the way it deforms due to the applied load. In this study the default meshing was done, the program automatically meshed the models of coconut palm climbers. The meshed models of KAU and Farmer's models generated in the ANSYS 15.0 softwares are presented below.

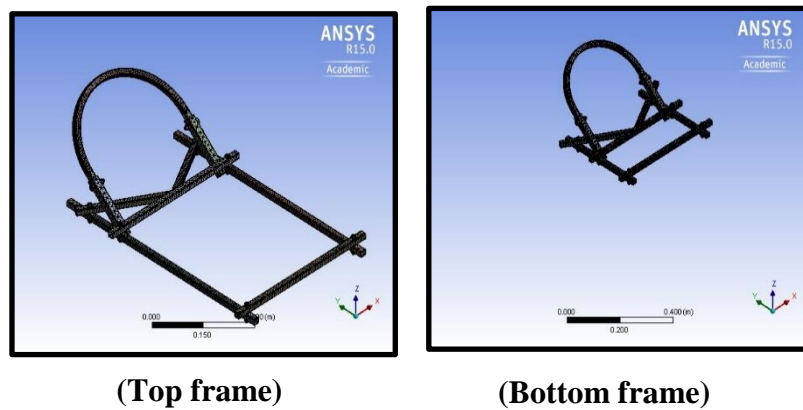

(a) KAU model

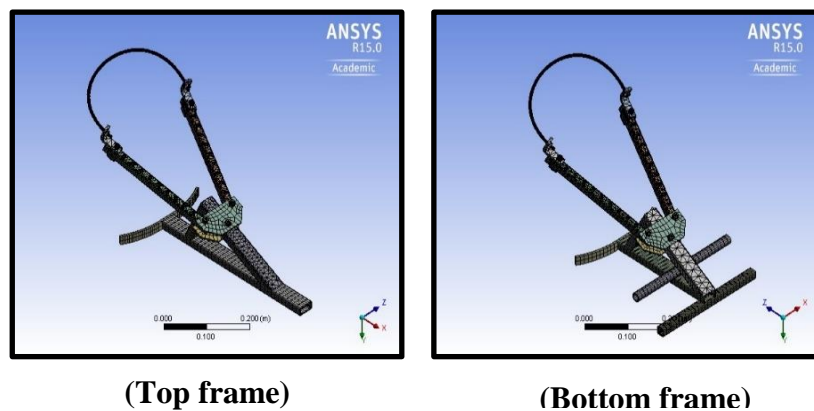

(b) Farmer's model

Plate 3.4 Meshed models of the climbers

Preprocessing software will access a CAD model and automatically mesh it with minimal input from the user. If the structure has more elements, the more accurate the results will be generated but the analysis will take longer to run. Hence it is a matter of finding a balance between accuracy and running time. Often a mesh is refined in areas of high stress or around complex shapes to increase the accuracy without increasing processing time.

Once the model is meshed, material properties needed to be defined and applied to the meshed part. These properties include the Young's modulus (a measure of material stiffness), density, Poisson's ratio and more depending on the complexity of the analysis. These material properties of coconut palm climbers will automatically update by selecting the type of material from ANSYS 15.0 material library. The materials used for the construction of top frame of the KAU model was galvanized iron and for the bottom frame was aluminium alloy. In the material library of ANSYS 15.0 Galvanized iron material is not available, the structural steel was hence taken as material of top frame of KAU model as both having almost similar properties. The materials used for the construction of top and bottom frames of the Farmer's model was of structural steel. The material properties of structural steel and aluminium alloy are given in the Table 3.1.

Table 3.1 Material properties of the coconut climbers

Properties	Structural steel	Aluminium alloy
Density (kg m ⁻³)	7850	2770
Coefficient of Thermal Expansion (°C ⁻¹)	1.2×10^{-5}	2.3×10^{-5}
Specific Heat (J kg ⁻¹ °C ⁻¹)	434	875
Thermal conductivity (W m ⁻¹ °C ⁻¹)	60.5	144
Resistivity (ohm m)	1.7×10^{-7}	2.43×10^{-8}
Compressive Yield Strength (Pa)	2.5×10^8	2.8×10^8
Tensile Yield Strength (Pa)	2.5×10^8	2.8×10^8
Tensile Ultimate Strength (Pa)	4.6×10^8	3.1×10^8
Young's Modulus (Pa)	2×10^{11}	7.1×10^{10}
Bulk Modulus (Pa)	1.6667×10^{11}	6.9608×10^{10}
Shear Modulus (Pa)	7.6923×10^{10}	2.6692×10^{10}
Poisson's Ratio	0.3	0.33

The next step in the preprocessing stage is to define boundary conditions to the model. The boundary conditions include loads and fixed supports. Loads are usually defined as forces acting on a certain point, but can also be torques, pressures, temperatures, or even a velocity or acceleration such as gravity. In this mechanical analysis of coconut palm climbers, the force is the weight of the person climbing the palm and any other accessories carried with him. The analysis was hence carried out for the forces of 400, 500, 600, 700, 800, 900, and 1000 N separately for top and bottom frames of both the selected models. A minimum weight (force) of 400 N and maximum weight (force) of 1000 N for the operators were considered. It is assumed that major forces acting on the sitting point of the climbers in top frames and on the foot rest point in the bottom frames. The force applied on the climbers are shown below.

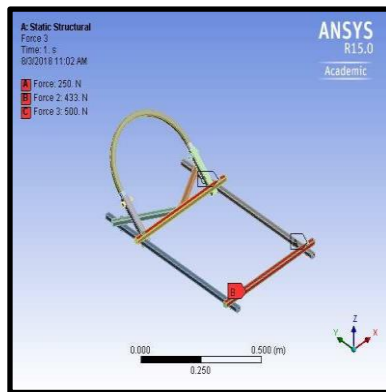

(Top frame)

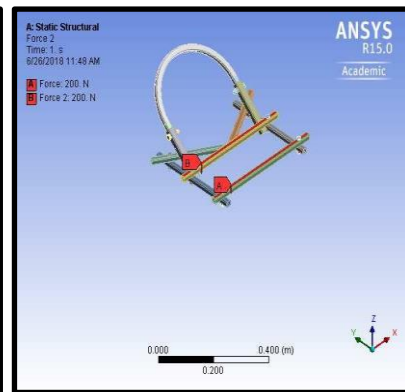

(Bottom frame)

(a) KAU model

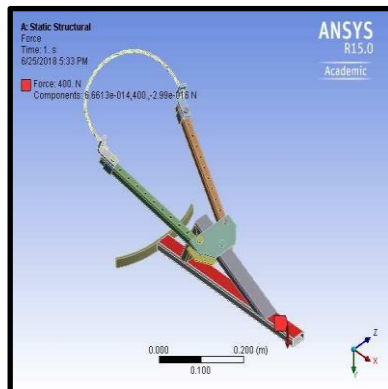

(Top frame)

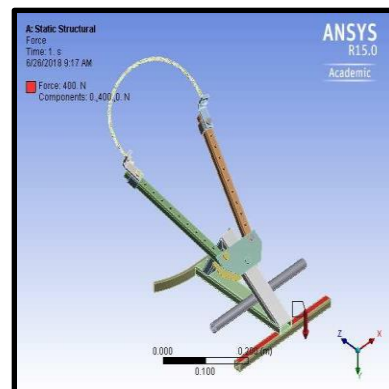

(Bottom frame)

(b) Farmer's model

Plate 3.5 Force applied on climbers

Fixed supports are constraints that define how and where the structure is held or bolted on and are required to stop the structure flying off into space when a force is applied. These are basically directs the software that which nodes are not allowed to move during the analysis. In the KAU model, the inner surface of bent tube and V tube was considered as the fixed support since the faces of these inner surfaces are in contact with the tree trunk. In the Farmer's model, the rope and inner face of

curve plate was considered as the fixed support since it will restrict the climber from falling down the palm. The boundary conditions applied on the selected coconut climbers are shown below.

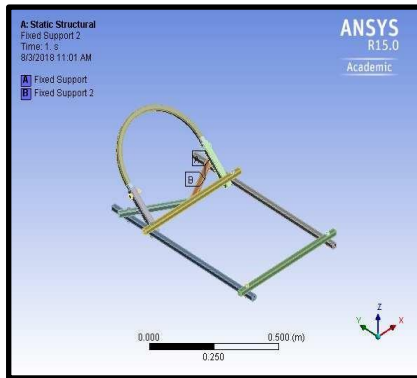

(Top frame)

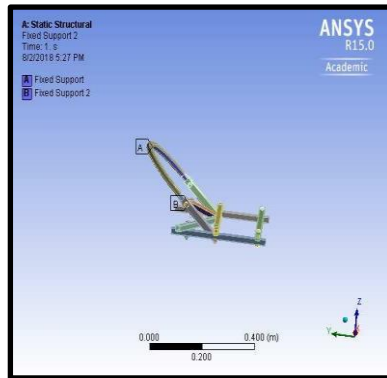

(Bottom frame)

(a) KAU model

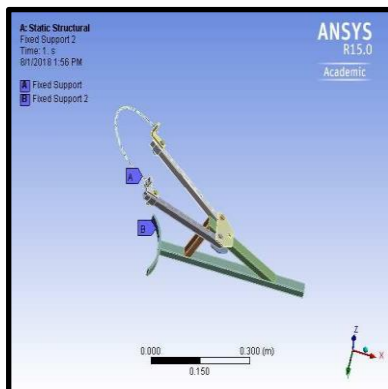

(Top frame)

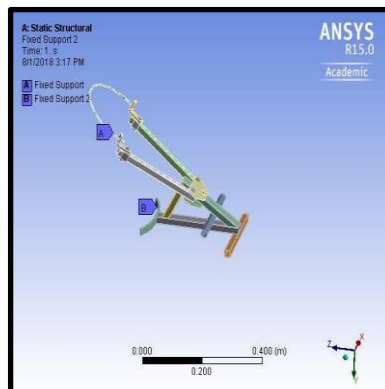

(Bottom frame)

(b) Farmer's model

Plate 3.6 Boundary conditions applied on climbers

Once the models have been meshed, materials are defined, loads and boundary conditions are applied, a preprocessed FEA model ready for analysis.

3.4.1.2 Solution

The next step in the FEM analysis is the computer do all the calculation work. The software that does all the calculation is called the solver. It goes through the meshed models created and solves a bunch of mathematical equations for each of the nodes to figure out results (Makange *et al.*, 2015).

3.4.1.3 Post processing

Post processing is the part of the analysis process that involves reviewing and interpreting the results from the solver. Whilst this may seem a little gimmicky with coloured pictures, technically known as contours and are a very intuitive way of interpreting the results. Also enables to get a pictorial view of the overall state of the part, regardless of technical knowledge anyone can interpret the data. The post processor will also show the deformed shape which helps the analyst to understand how the stresses are developing and what changes can be made to improve the design.

After acquiring these results it is necessary to interpolate the knowledge of engineering principles, stresses and material properties. After analysing the results, decisions regarding the changes has to be made to the part in order to reduce areas of high stress and determine how much material can be removed from areas of low stress. Analysis results will give idea of whether a part will break or not by comparing the stress values from the analysis results to the strength of the material. Every material has a yield and an ultimate strengths. If the stress within a part exceeds the yield strength, then that part will not return to its original shape when the load is removed. If the stress exceeds the ultimate strength, then the part will fracture and break. Ideally, the aim of this analysis is also to find the stresses within the parts of climbers are remain below or above the yield strength of the material.

3.4.2 Static analysis

The static analysis gives the effects of *steady* loading conditions on a structure, while ignoring inertia and damping effects, such as those caused by time varying loads. A static analysis can, however, include steady inertia loads (such as gravity and rotational velocity), and time varying loads that can be approximated as static equivalent loads (such as the static equivalent wind and seismic loads commonly defined in many building codes). Static analysis determines the displacements, stresses, strains, and forces in structures or components caused by loads that do not induce significant inertia and damping effects. Steady loading and response conditions are assumed; that is, the loads and the structure's response are assumed to vary slowly with respect to time.

In this study equivalent (Von-Mises) stress, equivalent elastic strain, and total deformation of both KAU and Farmer's models were found out at different loads viz. 400, 500, 600, 700, 800 N, 900 and 1000 N respectively.

3.4.2.1 Equivalent (von-Mises) stress

The climbers analysed in this study were manufactured by structural steel and aluminium alloy material, these are the ductile materials. Equivalent stress or Von Mises stress is commonly used to present FEA results because the structural safety for many engineering materials showing elasto-plastic properties. The maximum von Mises stress failure criterion is based on the von Mises-Hencky theory, also known as the scalar-energy theory or the maximum distortion energy theory. Von Mises yield criterion states that if the Von Mises stress of a material under load is equal or greater than the yield limit of the same material under simple tension then material will yield. Von Mises stress is a value used to determine if a given material will yield or fracture. It is a criterion for yielding, widely used for ductile materials such as metals. The materials which have the property of fracturing at large plastic deformations are called ductile materials. Von Mises stress is often used in design work because it allows any arbitrary three dimensional stress state to be represented

as a single positive stress value. Von Mises stress is a theoretical value that allows the comparison between the general 3D stresses with the uniaxial stress yield limit (Kurowski, 2012).

Von Mises yield criterion states that if the Von Mises stress of a material under load is equal or greater than the yield limit of the same material under simple tension then material will yield. Von Mises stress is a value used to determine if a given material will yield or fracture. It is a criterion for yielding, widely used for ductile materials such as metals.

In order to check the safety of the climbers, it is necessary to find the factor of safety. In static analysis factor of Safety is the ratio between the yield strength of material and maximum working stress in a part. It is the term describing the load carrying capacity of a system beyond the expected or actual loads. Essentially, the factor of safety is how much stronger the system is than it needs to be for an intended load. When the maximum stress in a part is more than the yield strength of the material then the factor of safety becomes less than 1, this means the structure is not safe and the failures will occur. If the factor of safety is more than 1, the structure is safe at that load (Anon., n.dc). Any additional load will cause the structure to fail. A structure with a FOS of 2 will fail at twice the design load.

$$\frac{\textit{Yield strength}}{\textit{Maximum stress}} = \textit{Factor of safety}$$

3.4.2.2 Equivalent elastic strain

Strain is the change in length divided by the original length of the object. A form of strain in which the distorted body returns to its original shape and size when the deforming force is removed is called elastic strain. When a strain is applied to a material it deforms elastically proportional to the force applied. However, after it has deformed a certain amount, the object can no longer take the strain and will break or fracture. The zone in which it bends under strain is called the elastic region.

In that region the object will bend and then return to its original shape when the force is abated (Anon., n.db).

3.4.2.3 Total deformation

Deformation is the change in shape or form of an object due to the application of a force. As deformation occurs, internal inter molecular forces arise that oppose the applied force. If the applied force is not too great, these forces may be sufficient to completely resist the applied force and allow the object to assume a new equilibrium state and to return to its original state when the load is removed. A larger applied force may lead to a permanent deformation of the object or even to its structural failure. Deformation is proportional to the stress applied within the elastic limits of the material. Total deformation is the vector sum of all directional displacements of the systems. Deformation results from ANSYS workbench as total deformation or directional deformation. Both of them are used to obtain displacements from stresses. The main difference is the directional deformation calculates for the deformations in X, Y, and Z planes for a given structure. In total deformation, it gives a square root of the summation of the square of x-direction, y-direction and z-direction means vector sum of the all directional displacements of the structure (Anon., n.da).

3.4.3 Fatigue analysis

It is well known that many parts may work well initially, but fail in service due to fatigue caused by repeated cyclic loading. In practice, loads significantly below static limits can cause failure if the load is repeated sufficient times. Fatigue analysis implies in characterizing the capability of a material to survive many cycles that experience during its entire life time (Tripathi and Crasta, 2017).

Fatigue life is calculated as the number of stress cycles that an object or material can handle before the failure. There are a number of different factors that can influence fatigue life including the type of material being used, structure, shape

and temperature changes. In practice loads significantly below static limits can cause failure if the load is repeated sufficient times. Characterizing the capability of a material to survive the many cycles a component may experience during its lifetime is the aim of fatigue analysis. The number of cycles indicates the number of times the loads imposed on it.

3.4.4 Factor of safety

In order to check the safety of the climbers, it is necessary to find the factor of safety. In fatigue analysis the factor of safety is the ratio between the fatigue limit of material and maximum working stress in a part. It will indicate, how many number of cycles the part can take safely under expected or actual loads. Essentially, the factor of safety is how much stronger the system is than it needs to be for an intended load. When the maximum stress in a part is more than the fatigue limit of the material then the factor of safety becomes less than 1, this means the structure is not safe and the failures will occur. If the factor of safety is more than 1, the structure is safe at that load. Structure with a F.O.S of exactly 1 will support only the design load and no more. The highest stress that a material can withstand for an infinite number of cycles without breaking is called fatigue limit or also called endurance limit

$$\frac{\textit{Fatigue limit}}{\textit{Maximum stress}} = \textit{Factor of safety}$$

3.5 DRAFT TEST CODE

Test codes are necessary to test any agricultural machines or equipment to issue test reports by any testing agencies. No specific test codes are available to test these climbers, irrespective of the models. In this study an attempt was made to prepare the draft test code for the coconut climbers. The draft test code formulated with view of improvement of mechanical coconut climber in all aspects.

Testing includes a determination of functional performance characteristics of machine, durability, wear testing, external forces acting on implement, stresses developed in different parts of implement due to static or dynamic loading. Testing of farm machines useful to both farmers as well as to the manufactures. Testing encourages improvement in quality and functional stability. Testing of machines helps farmers in proper selection of implement, suitable power source and required adjustments in machines. It helps manufacturers in commercial publicity of product, better design and sales promotion. Comparable data for similar data for similar machines is available to manufacturers, which help them in improving the design of their product.

Different countries have established various organizations and institutions, which test the farm equipment, supplied by the manufacturers and submit the confidential reports. The foremost duties of such organizations are to first develop the standard test codes for different types of farm machines, which forms the basis for testing of the machines. Government of India has established bureau of Indian Standards, which does the job of preparing standard test codes. Other countries in the world have also similar organizations; some of them are Nebraska Testing Centre in UAS, British Standards Institutions London, in U.K, organization for the economic co-operation and development (O.E.C.D.), Paris and International Organization for Standardization (ISO) etc.

Bureau of Indian Standards has published Indian Standards on majority of agricultural machines/components being used in the country. Testing of machine is done as per relevant Indian Standards. Indian Standard has not been formulated for tree climbers. In this study an attempt was made to prepare a draft test code and procedure matching the essential requirements of the coconut palm climbers for testing purposes.

The many parameters regarding coconut palm climbers were considered viz., its field performance, mechanical strength and stability, ergonomical parameters, safety requirements etc.

CHAPTER IV

RESULT AND DISCUSSION

The results of the study on the computer aided mechanical analysis of KAU and Farmer's models of coconut climbers using ANSYS 15.0 software are presented here. The results of static and fatigue analysis of KAU and Farmer's models of the climbers under different loading conditions are compared. Accordingly the optimized design of coconut palm climber is suggested. The draft test code for the testing of coconut palm climbers is also formulated under this study.

4.1 KAU MODEL

4.1.1 Static analysis

The static analysis was carried out separately for top and bottom frames of the KAU model at loads of 400, 500, 600, 700, 800, 900 and 1000 N respectively. The equivalent (Von-Mises) stress, equivalent elastic strain and total deformation were found out in the analysis using ANSYS 15.0 software at each load.

4.1.1.1 Top frame

The top frame was made of galvanized iron. As galvanized iron was not available in the material library of ANSYS 15.0 software the structural steel was selected for the analysis. The material properties of galvanized iron and structural steels were almost similar, hence the selection of material was correct. The boundary conditions were fixed as explained in art 3.4.1.1. The meshed model of top frame have a total 54070 elements and 99600 nodes.

4.1.1.1.1 Equivalent (Von-Mises) stress

The materials used for fabricating the KAU model were structural steel and aluminium alloy. These are of ductile in nature and so Von Mises stress was observed. The Von Mises stresses of the top frame of the KAU model is shown in Plate 4.1 (a) to (g) at various loads of 400,500,600,700,800,900 and 1000 N. A maximum Von Mises stress of 1.944×10^8 Pa was observed at a load of 1000 N. The maximum Von Mises stress was only 7.7766×10^7 Pa when the load was 400 N. The maximum Von Mises stress was observed in rope tube. From the Table 4.1, it is observed that as the load increased from 400 to 1000 N, the Von Mises stress were also increased.

4.1.1.1.2 Equivalent elastic strain

Equivalent elastic strain is the recoverable elastic deformation of a solid if the stress is removed. The equivalent elastic strain of top frame of the KAU model is illustrated in Plate 4.2 (a) to (g) under loads of 400,500,600,700,800,900 and 1000 N. The maximum equivalent elastic strain at 400 N and 1000 N were 4.0179×10^{-4} m/m and 1.0044×10^{-3} m/m respectively. The maximum stain occurred on rope tube and minimum on bent tube. From the Table 4.1, it is observed that as the load increased from 400 to 1000 N, the equivalent elastic strain were also increased.

4.1.1.1.3 Total deformation

Deformation is the change in shape or form of an object due to the application of a force (load). The total deformation of top frame of the KAU model is illustrated in Plate 4.3 (a) to (g) under loads of 400,500,600,700,800,900 and 1000 N. The maximum total deformation at 400 N and 1000 N were 2.1075×10^{-3} m and 5.2681×10^{-3} m respectively. The maximum and minimum deformation occurred on straight tube. From the Table 4.1 it is observed that as the load increased from 400 to 1000 N, the total deformation were also increased.

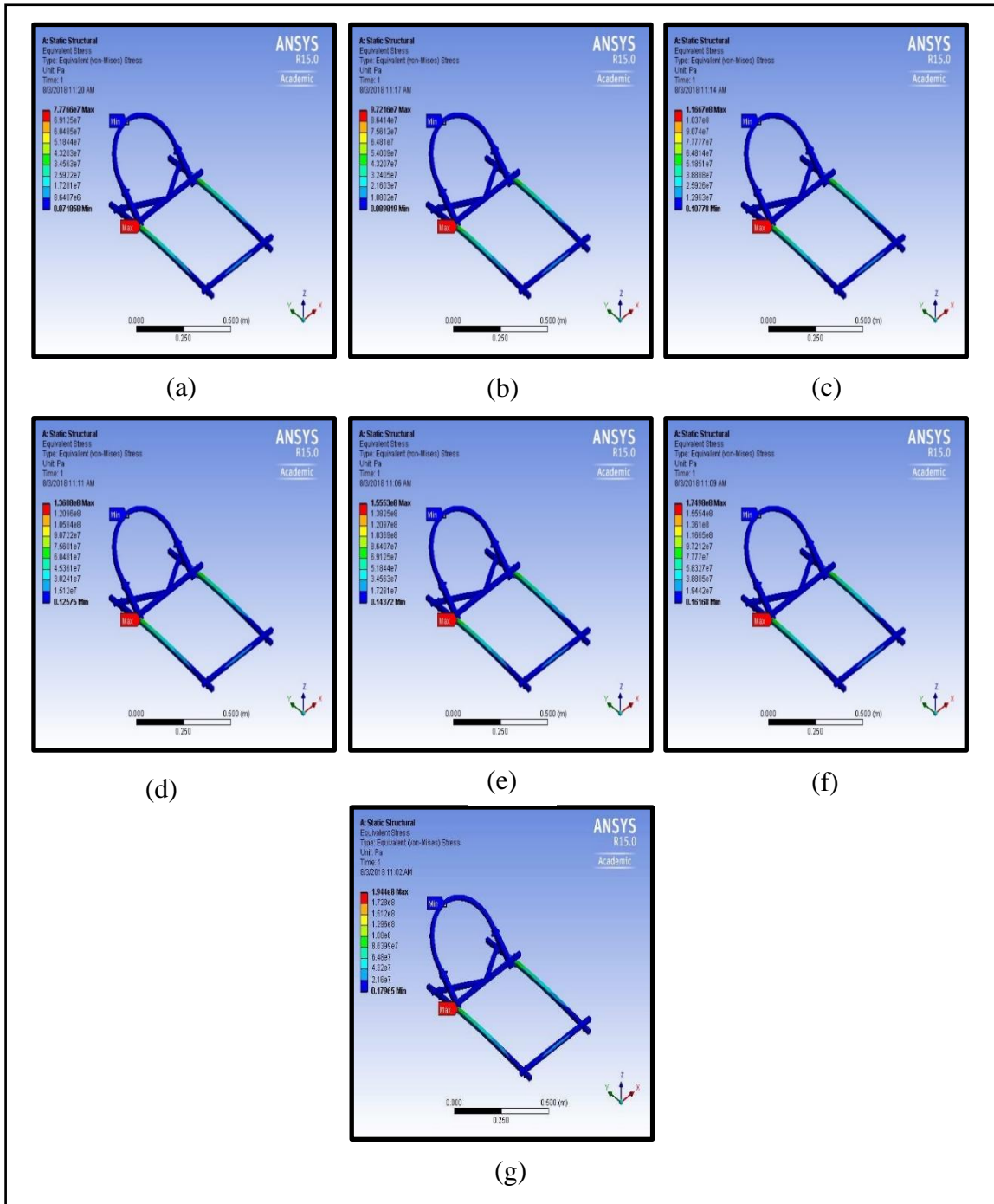

Plate 4.1 Equivalent (Von-Mises) stress of the top frame of KAU model at loads of (a) 400 N, (b) 500 N, (c) 600 N, (d) 700 N, (e) 800 N, (f) 900 N and (g) 1000N

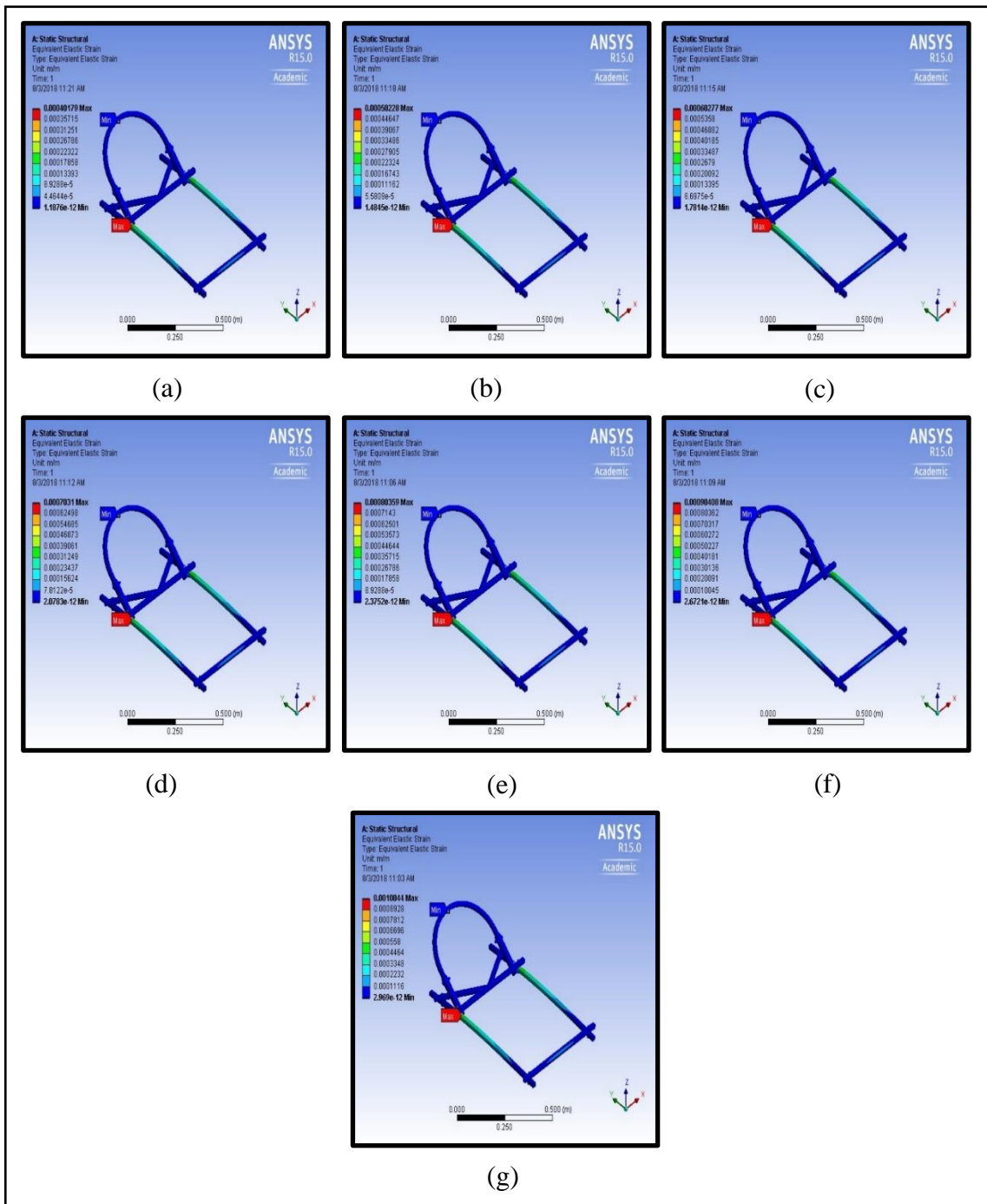

Plate 4.2 Equivalent elastic strain of the top frame of KAU model at loads of (a) 400 N, (b) 500 N, (c) 600 N, (d) 700 N, (e) 800 N, (f) 900 N and (g) 1000N

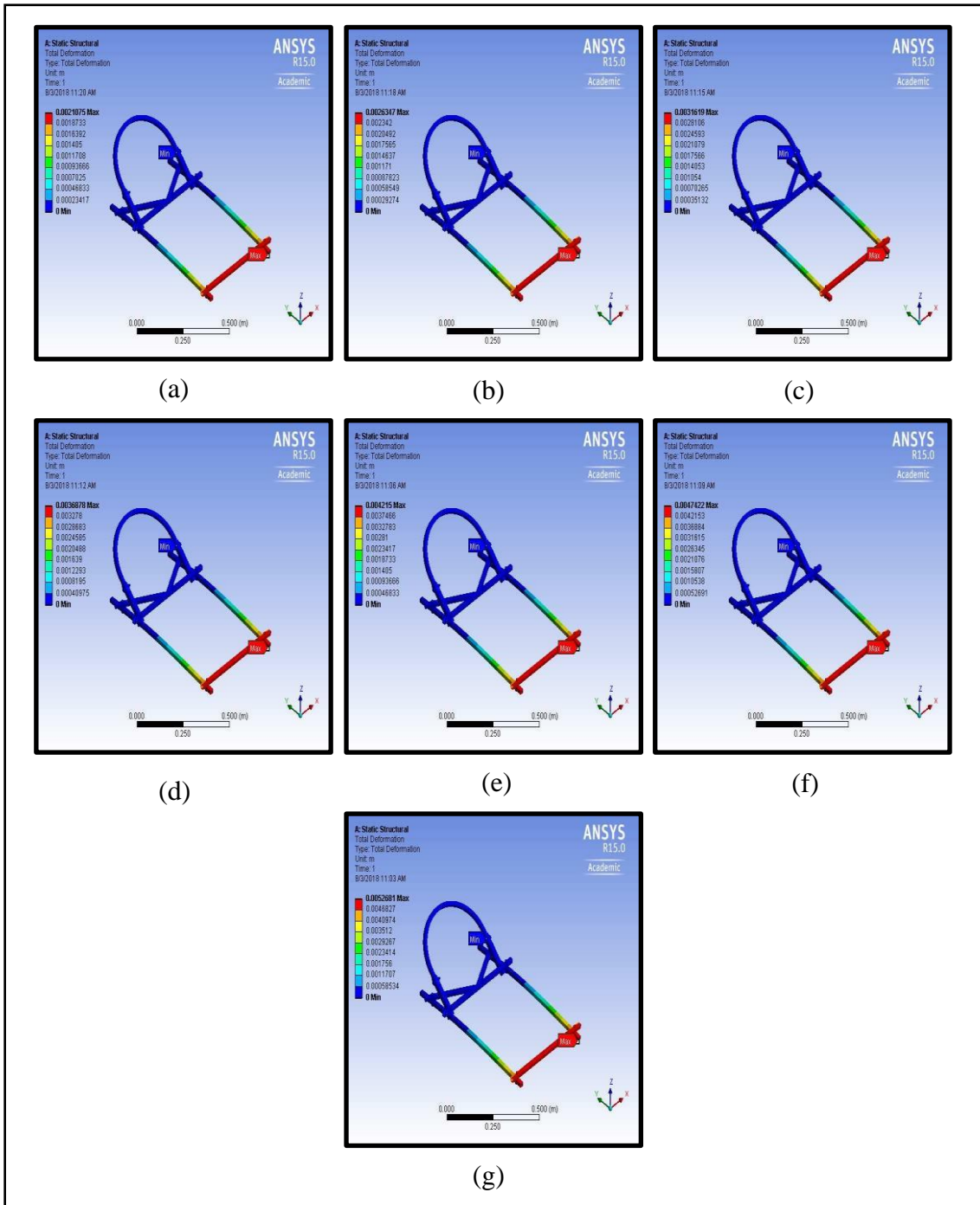

Plate 4.3 Total deformation of the top frame of KAU model at loads of (a) 400 N, (b) 500 N, (c) 600 N, (d) 700 N, (e) 800 N, (f) 900 N and (g) 1000N

Table 4.1 Static analysis of the top frame of KAU model

Load (N)	Equivalent (von-Mises) Stress (Pa) (max.)	Equivalent Elastic Strain (m/m) (max.)	Total deformation (m) (max.)
400	7.7766×10^7	4.0179×10^{-4}	2.1075×10^{-3}
500	9.7216×10^7	5.0228×10^{-4}	2.6347×10^{-3}
600	1.1667×10^8	6.0277×10^{-4}	3.1619×10^{-3}
700	1.3608×10^8	7.031×10^{-4}	3.6878×10^{-3}
800	1.5553×10^8	8.0359×10^{-4}	4.215×10^{-3}
900	1.7498×10^8	9.0408×10^{-4}	4.7422×10^{-3}
1000	1.944×10^8	1.0044×10^{-3}	5.2681×10^{-3}

4.1.1.1.4 Factor of safety

$$\frac{\text{Yield strength}}{\text{Maximum stress}} = \text{Factor of safety}$$

In order to determine the safety of the climber under the loads of 400 N to 1000 N, the equivalent (Von-Mises) stress values obtained from the static analysis were recorded. The yield strength of the material used in the fabrication of KAU model is then recorded from the material library of ANSYS 15.0. The factor of safety of top frame of KAU model at 400 N to 1000 N loads are given in the Table 4.2.

Table 4.2 Factor of safety of top frame of KAU model

Load (N)	Equivalent (Von-Mises) Stress (Pa)	Yield strength of the material (Pa)	Factor of safety
400	7.7766×10^7	2.5×10^8	3.2
500	9.7216×10^7	2.5×10^8	2.6
600	1.1667×10^8	2.5×10^8	2.1
700	1.3608×10^8	2.5×10^8	1.8
800	1.5553×10^8	2.5×10^8	1.6
900	1.7498×10^8	2.5×10^8	1.4
1000	1.944×10^8	2.5×10^8	1.3

The results shown in Table 4.1 and Table 4.2 indicate that, as the load on the climber increased the equivalent (Von-Mises) stress, equivalent elastic strain and total deformation are also increased. The stress at each loads were less than the yield strength of the structural steel material i.e. 250 MPa. Hence the factor of safety will be > 3 at 400 N load, > 2 at 500 and 600 N loads and > 1 at 700, 800, 900 and 1000 N loads. If the factor of safety is more than one then the structure will not fail. The existing top frame of the KAU model is safe to operate up to 1000 N load. As the load get increases the factor of safety decreases (Figure 4.1). The maximum stress, stain observed in rope tube and deformation observed in straight tube. In order to increase the factor of safety it is suggested to increase the cross sectional dimensions, change the material or design of the straight tube and rope tube where the structure will undergo maximum deformation and stress.

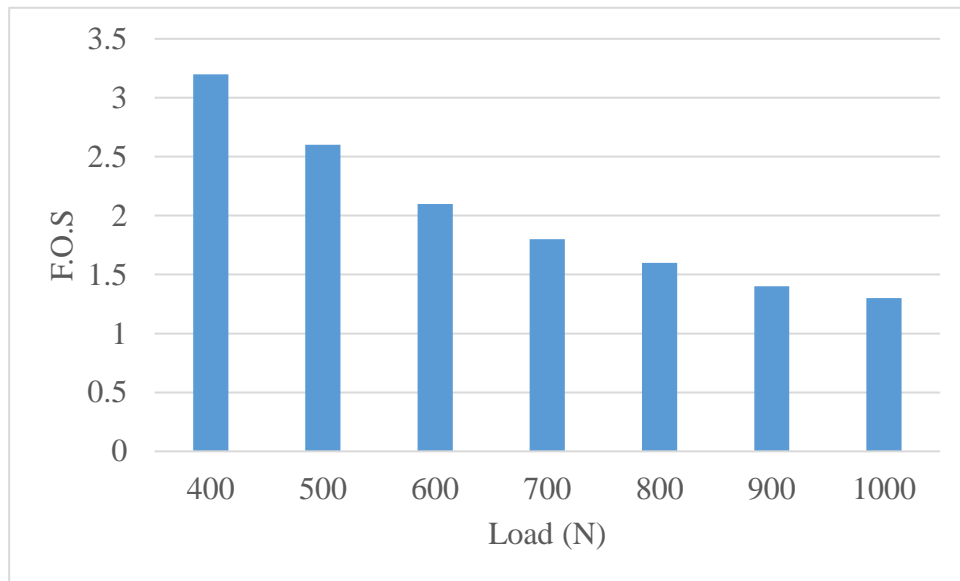

Fig. 4.1 F.O.S of the top frame of KAU model

4.1.1.2 Bottom frame

The bottom frame is made up of aluminium alloy material. All the boundary conditions were applied to the bottom frame as mentioned in the art. 3.4.1.1 and the analysis was carried out for each load. The meshed model of bottom frame have 74048 elements and 169412 nodes.

4.1.1.2.1 Equivalent (Von-Mises) stress

The materials used for fabricating the KAU model were structural steel and aluminium alloy. These are of ductile in nature and so Von Mises stress was observed. The Von Mises stresses of the bottom frame of the KAU model is shown in Plate 4.4 (a) to (g) at various loads of 400,500,600,700,800,900 and 1000 N. A maximum Von Mises stress of 2.0866×10^8 Pa was observed at a load of 1000 N, but the maximum Von Mises stress was only 8.3463×10^7 Pa when the load was 400 N. the maximum Von Mises stress was observed in spring lock washer and minimum in bent tube. From the Table 4.3 it is observed that as the load increased from 400 to 1000 N, the Von Mises were also increased.

4.1.1.2.2 Equivalent elastic strain

Equivalent elastic strain is the recoverable elastic deformation of a solid if the stress is removed. The equivalent elastic strain of bottom frame of the KAU model is illustrated in Plate 4.5 (a) to (g) under loads of 400,500,600,700,800,900 and 1000 N. The maximum equivalent elastic strain at 400 N and 1000 N were 7.7772×10^{-4} m/m and 1.9443×10^{-3} m/m respectively. The maximum strain occurred on bottom tube and minimum on bent tube. From the Table 4.3 it is observed that as the load increased from 400 to 1000 N, the equivalent elastic strain were also increased.

4.1.1.2.3 Total Deformation

Deformation is the change in shape or form of an object due to the application of a force (load). The total deformation of bottom frame of the KAU model is illustrated in Plate 4.6 (a) to (g) under loads of 400,500,600,700,800,900 and 1000 N. The maximum total deformation at 400 N and 1000 N was 5.9789×10^{-4} m and 1.4947×10^{-3} m respectively. The maximum deformation occurred on bottom tube and minimum on V bent. From the Table 4.3 it is observed that as the load increased from 400 to 1000 N, the total deformation were also increased.

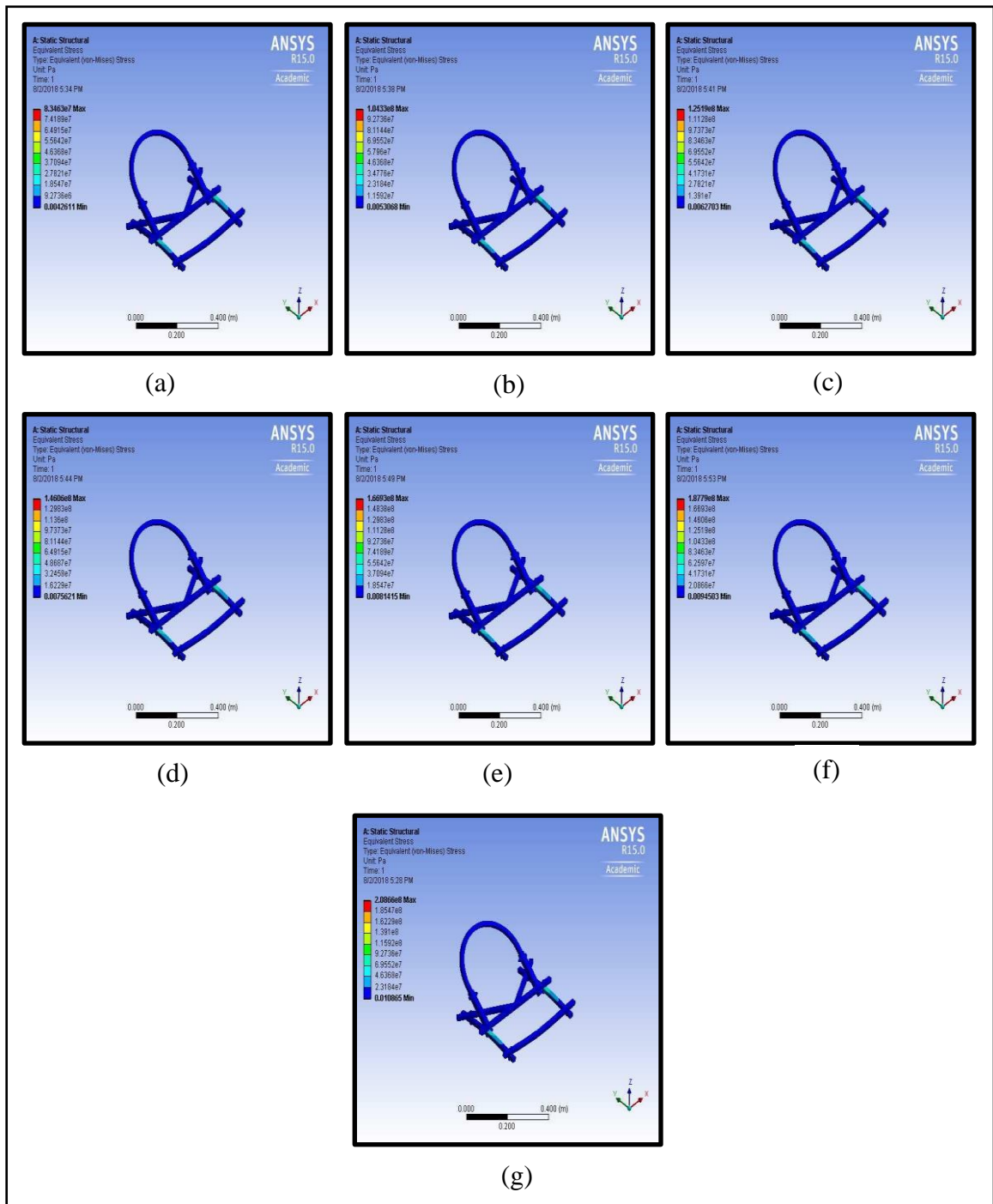

Plate 4.4 Equivalent (Von-Mises) stress of the bottom frame of KAU model at loads of (a) 400 N, (b) 500 N, (c) 600 N, (d) 700 N, (e) 800 N, (f) 900 N and (g) 1000N

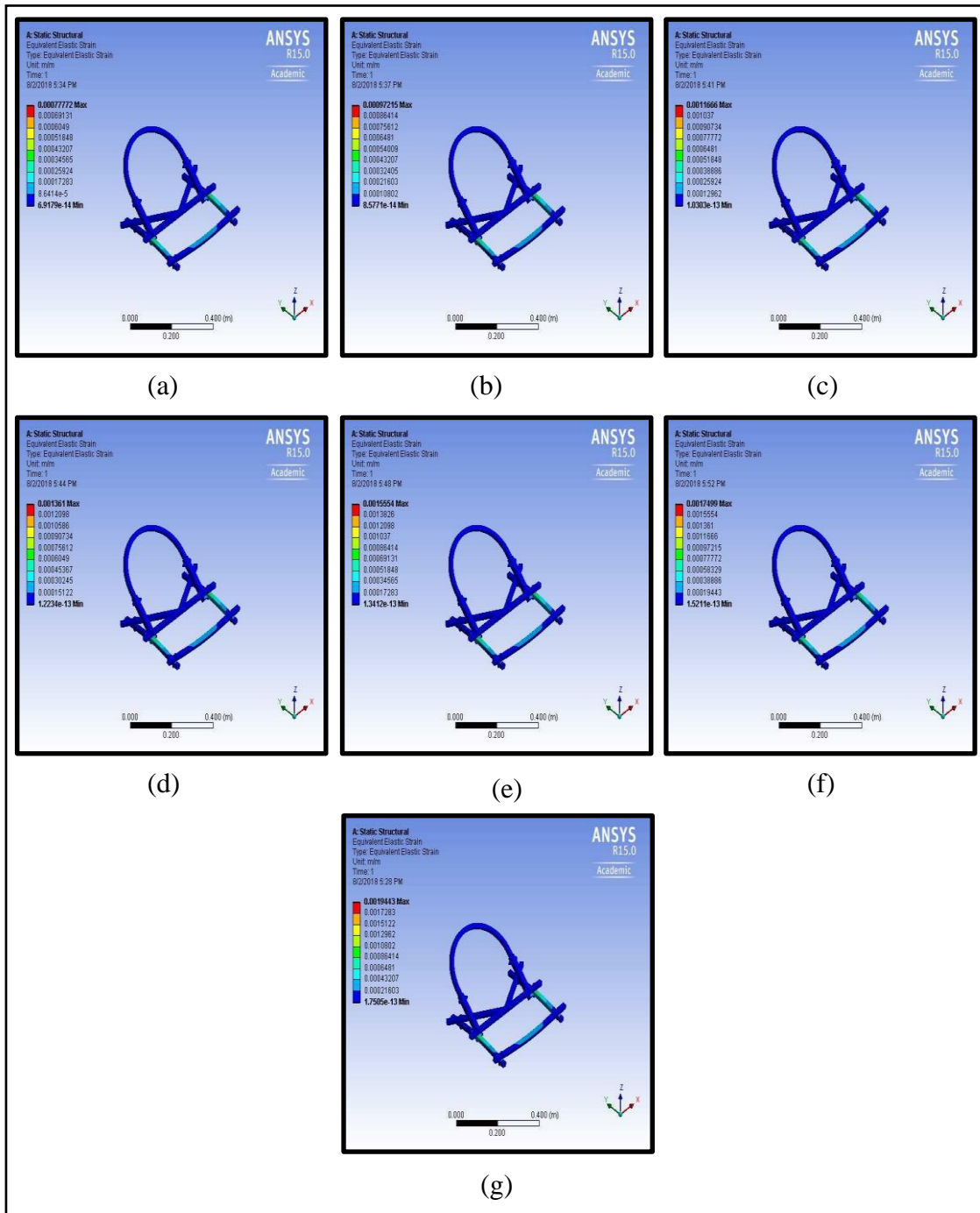

Plate 4.5 Equivalent elastic strain of the bottom frame of KAU model at loads of (a) 400 N, (b) 500 N, (c) 600 N, (d) 700 N, (e) 800 N, (f) 900 N and (g) 1000N

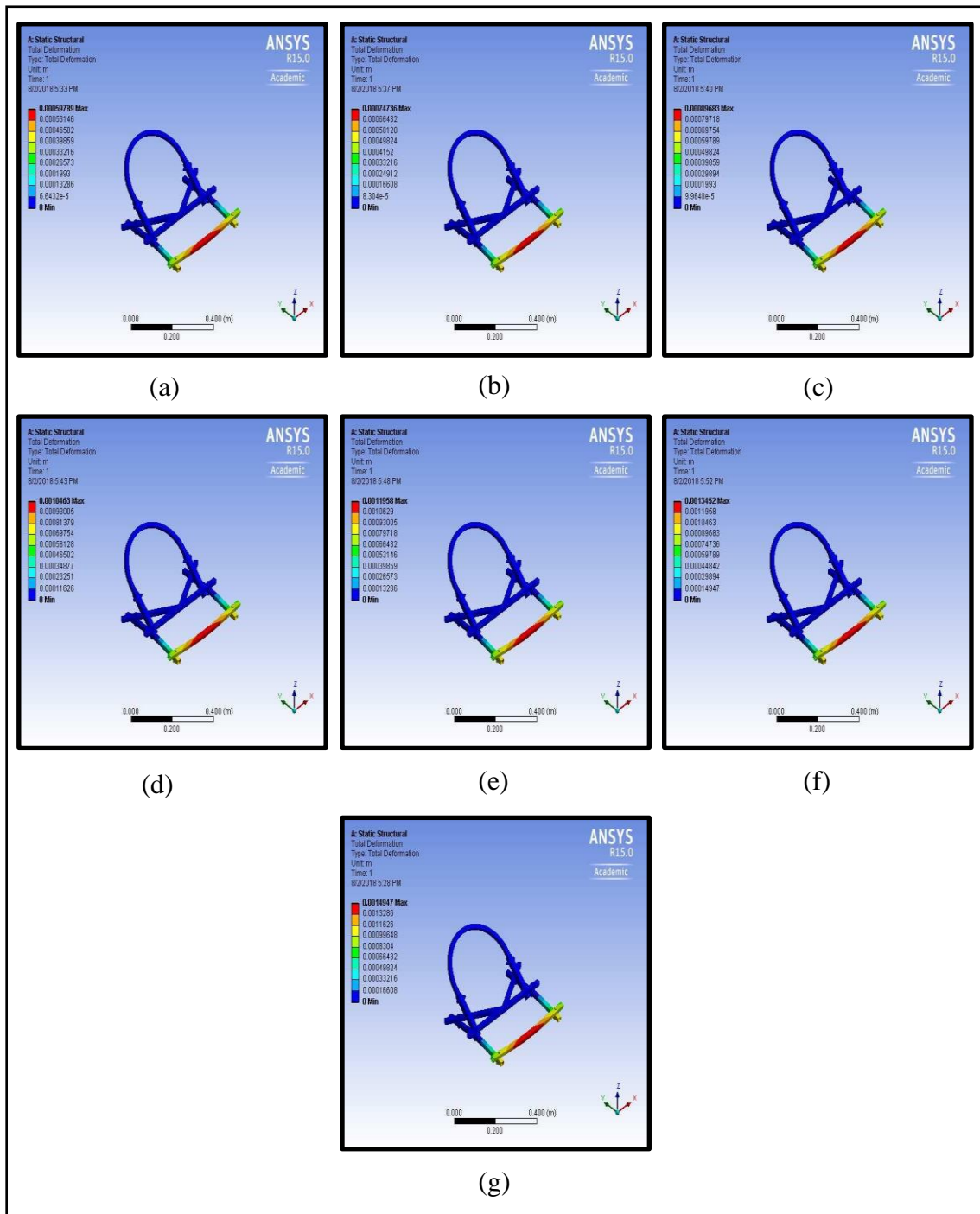

Plate 4.6 Total deformation of the bottom frame of KAU coconut palm climber at loads of a) 400 N, (b) 500 N, (c) 600 N, (d) 700 N, (e) 800 N, (f) 900 N and (g) 1000N

Table 4.3 Static analysis of the bottom frame of KAU model

Load (N)	Equivalent (von-Mises) Stress (Pa) (max.)	Equivalent Elastic Strain (m/m) (max.)	Total deformation (m) (max.)
400	8.3463×10^7	7.7772×10^{-4}	5.9789×10^{-4}
500	1.0433×10^8	9.7215×10^{-4}	7.4736×10^{-4}
600	1.2519×10^8	1.1666×10^{-3}	8.9683×10^{-4}
700	1.4606×10^8	1.361×10^{-3}	1.0463×10^{-3}
800	1.6693×10^8	1.5554×10^{-3}	1.1958×10^{-3}
900	1.8779×10^8	1.7499×10^{-3}	1.3452×10^{-3}
1000	2.0866×10^8	1.9443×10^{-3}	1.4947×10^{-3}

4.1.1.2.4 Factor of safety

The factor of safety of bottom frame of KAU model at 400 N to 1000 N loads are given in the Table 4.4.

Table 4.4 Factor of safety of bottom frame of KAU model

Load (N)	Equivalent (Von- Mises) Stress (Pa)	Yield strength of the material (Pa)	Factor of safety
400	8.3463×10^7	2.8×10^8	3.4
500	1.0433×10^8	2.8×10^8	2.7
600	1.2519×10^8	2.8×10^8	2.2
700	1.4606×10^8	2.8×10^8	1.9
800	1.6693×10^8	2.8×10^8	1.7
900	1.8779×10^8	2.8×10^8	1.5
1000	2.0866×10^8	2.8×10^8	1.4

The results shown in the Table 4.3 and Table 4.4 indicate that up to a load of 1000 N the bottom frame of the KAU model is safe to operate because the factor of safety is >1 . The factor of safety > 1 at 400 N load, > 2 at 500 and 600 N loads and > 1 at 700 to 1000 N loads.

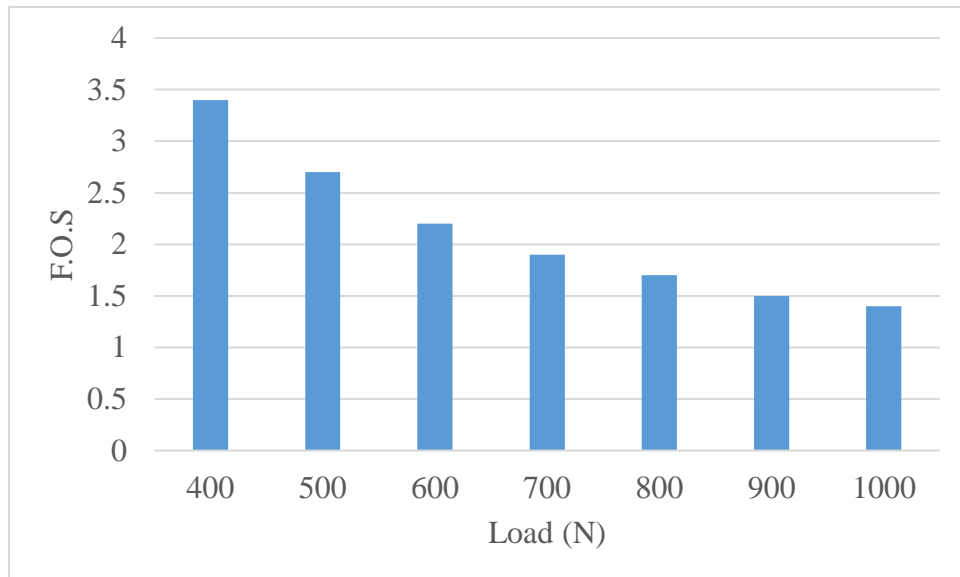

Fig. 4.2 F.O.S of the bottom frame of KAU model

4.1.2 Fatigue analysis

The fatigue analysis was carried out separately for top and bottom frames of the KAU model at loads of 400, 500, 600, 700, 800, 900 and 1000 N. The fatigue life and factor of safety were found out using ANSYS 15.0 software for each load.

4.1.2.1 Top frame

The top frame is made with galvanized iron. Since galvanized iron is not available in the material library of ANSYS 15.0 software the structural steel was selected.

4.2.2.1.1 Fatigue life

Fatigue life is the number of stress cycles that an object or material can handle before failure. The fatigue life of top frame of the KAU model is illustrated in Plate 4.7 (a) to (g) under loads of 400,500,600,700,800,900 and 1000 N. The minimum fatigue life at 400 N and 1000 N was 1×10^6 cycles and 5.0084×10^5 cycles respectively. The minimum fatigue life occurs in nut. From the Table 4.5 it is observed that as the load increased from 400 to 1000 N, the fatigue life decreased.

4.1.2.1.2 Factor of safety (Fatigue)

The factor of safety of top frame of the KAU model is illustrated in Plate 4.8 (a) to (g) under loads of 400,500,600,700,800,900 and 1000 N. The minimum factor of safety at 400 N and 1000 N was 2.2169 and 0.88684 respectively. The minimum factor of safety occurs in rope tube. From the table 4.5 it is observed that as the load increased from 400 to 1000 N, the factor of safety decreased.

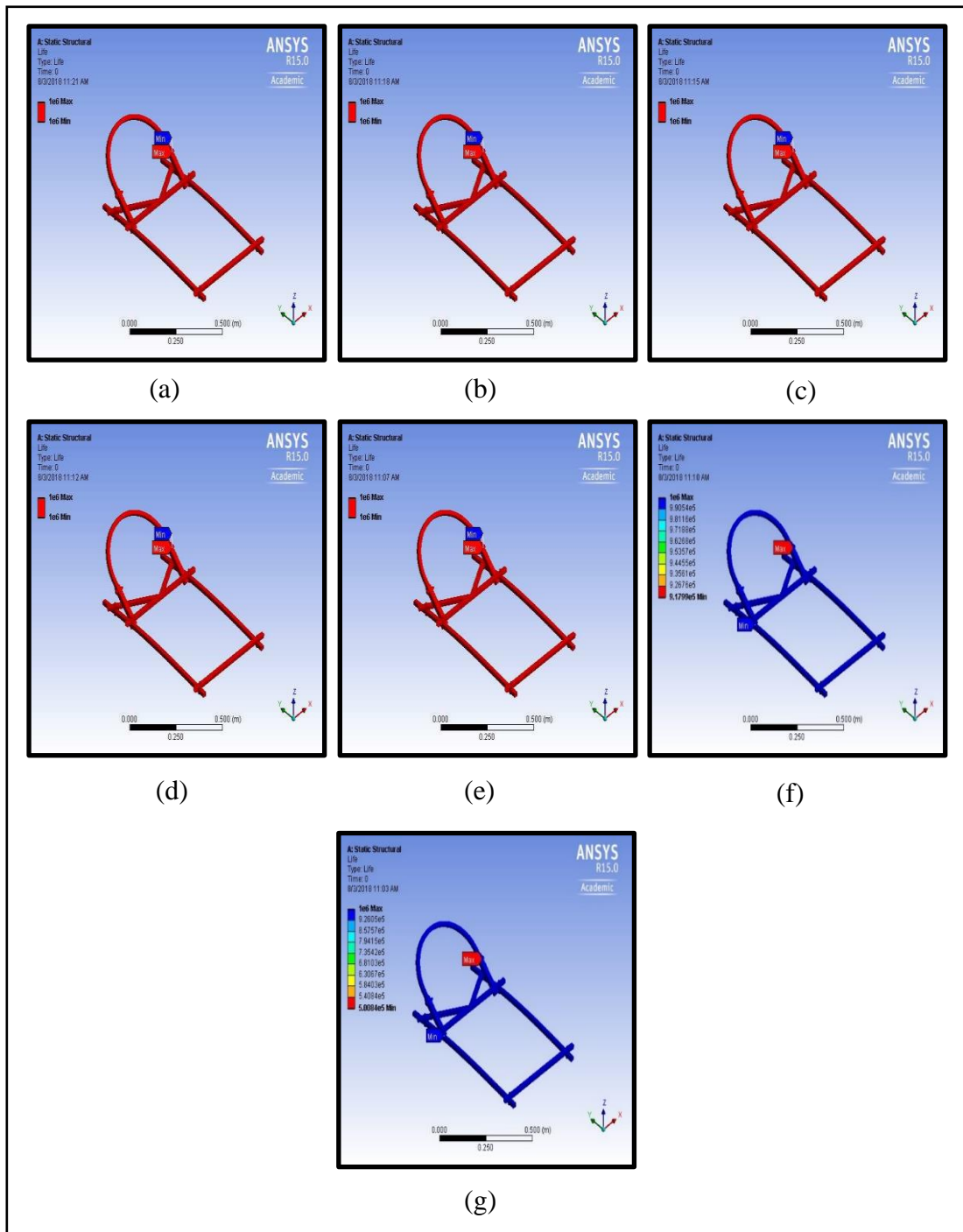

Plate 4.7 Fatigue life of the top frame of KAU model at loads of (a) 400 N, (b) 500 N, (c) 600 N, (d) 700 N, (e) 800 N, (f) 900 N and (g) 1000N

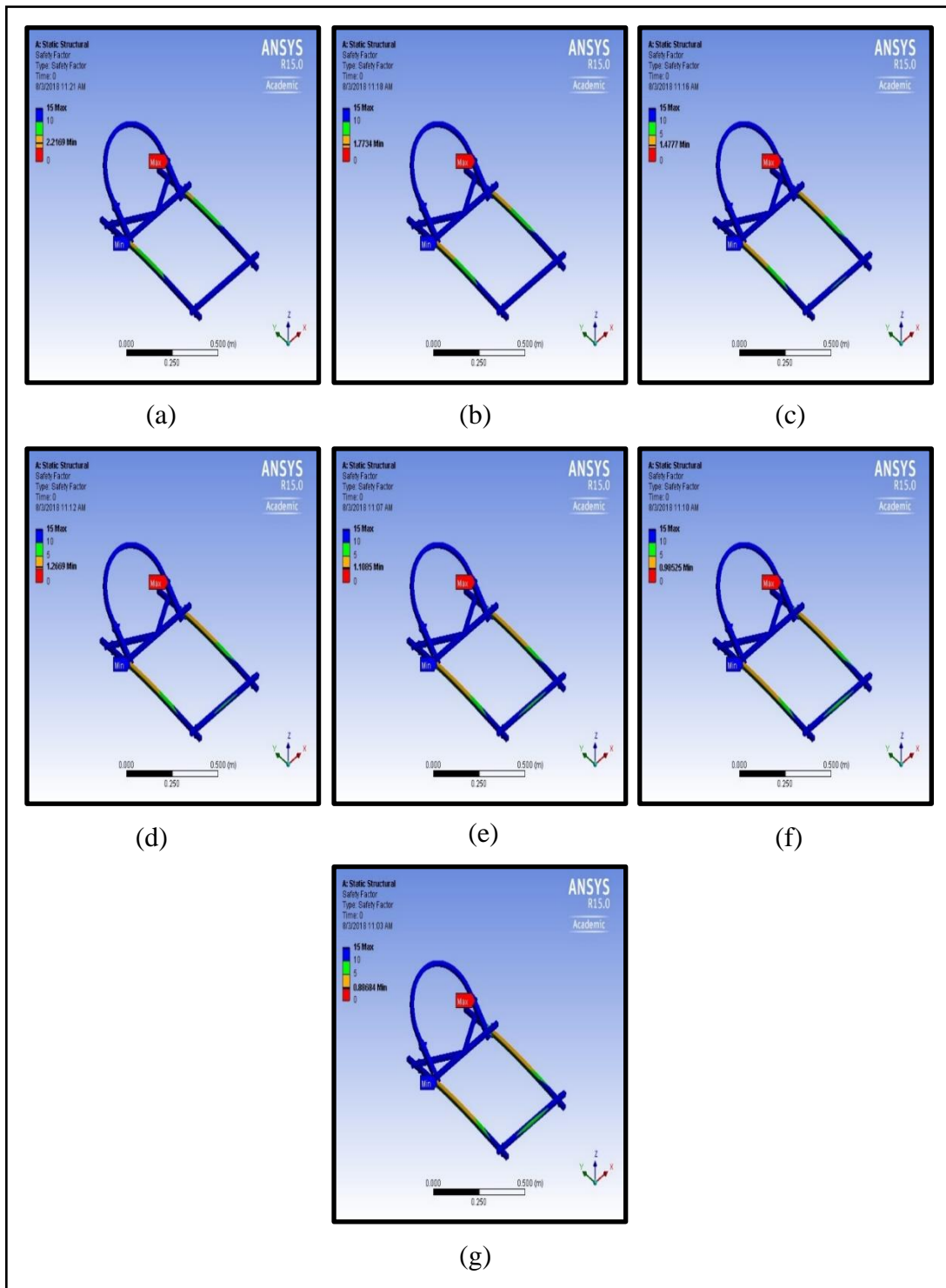

Plate 4.8 Factor of safety of the top frame of KAU model at loads of (a) 400 N, (b) 500 N, (c) 600 N, (d) 700 N, (e) 800 N, (f) 900 N and (g) 1000N

Table 4.5 Fatigue analysis of top frame of KAU model

Load (N)	Fatigue life (cycles)	Factor of safety
400	1×10^6	2.2169
500	1×10^6	1.7734
600	1×10^6	1.4777
700	1×10^6	1.2669
800	1×10^6	1.1085
900	9.1799×10^5	0.98525
1000	5.0084×10^5	0.88684

The results mentioned in the Table 4.5 show that as the load increased from 400 N to 1000 N the number of cycles are reduced. This reveals that the fatigue life is decreasing. Hence it is presumed that without any structural failure of the climber it can bear infinite fatigue life cycles up to 800 N load, 9.1799×10^5 cycles at 900 N load and 5.0084×10^5 cycles at 1000 N load. As the load increased the number of cycles reduced due to increase in stress. The factor of safety was found about 2.2 with respect to fatigue limit of 86.2 MPa at 400 N load. Hence the minimum fatigue life found at spring lock washer it is suggested to change the washers regularly.

4.1.2.2 Bottom frame

The bottom frame is made of aluminium alloy. All the boundary conditions were applied to it as explained in art. 3.4.1.1 and the analysis was carried out for each load.

4.1.2.2.1 Fatigue life

Fatigue life is the number of stress cycles that an object or material can handle before failure. The fatigue life of bottom frame of the KAU model is illustrated in Plate 4.9 (a) to (g) under loads of 400,500,600,700,800,900 and 1000 N. The minimum fatigue life at 400 N and 1000 N were 1×10^6 cycles and 3.3321×10^5 cycles respectively. The minimum fatigue life occurs in spring lock washer. From

the Table 4.6 it is observed that as the load increased from 400 to 1000 N, the fatigue life decreased.

4.1.2.2.2 Factor of safety

The factor of safety of bottom frame of the KAU model is illustrated in plate 4.10 (a) to (g) under loads of 400,500,600,700,800,900 and 1000 N. The minimum factor of safety at 400 N and 1000 N were 2.0656 and 0.82624 respectively. The minimum factor of safety occurs in spring lock washer. From the Table 4.6 it is observed that as the load increased from 400 to 1000 N, the factor of safety decreased.

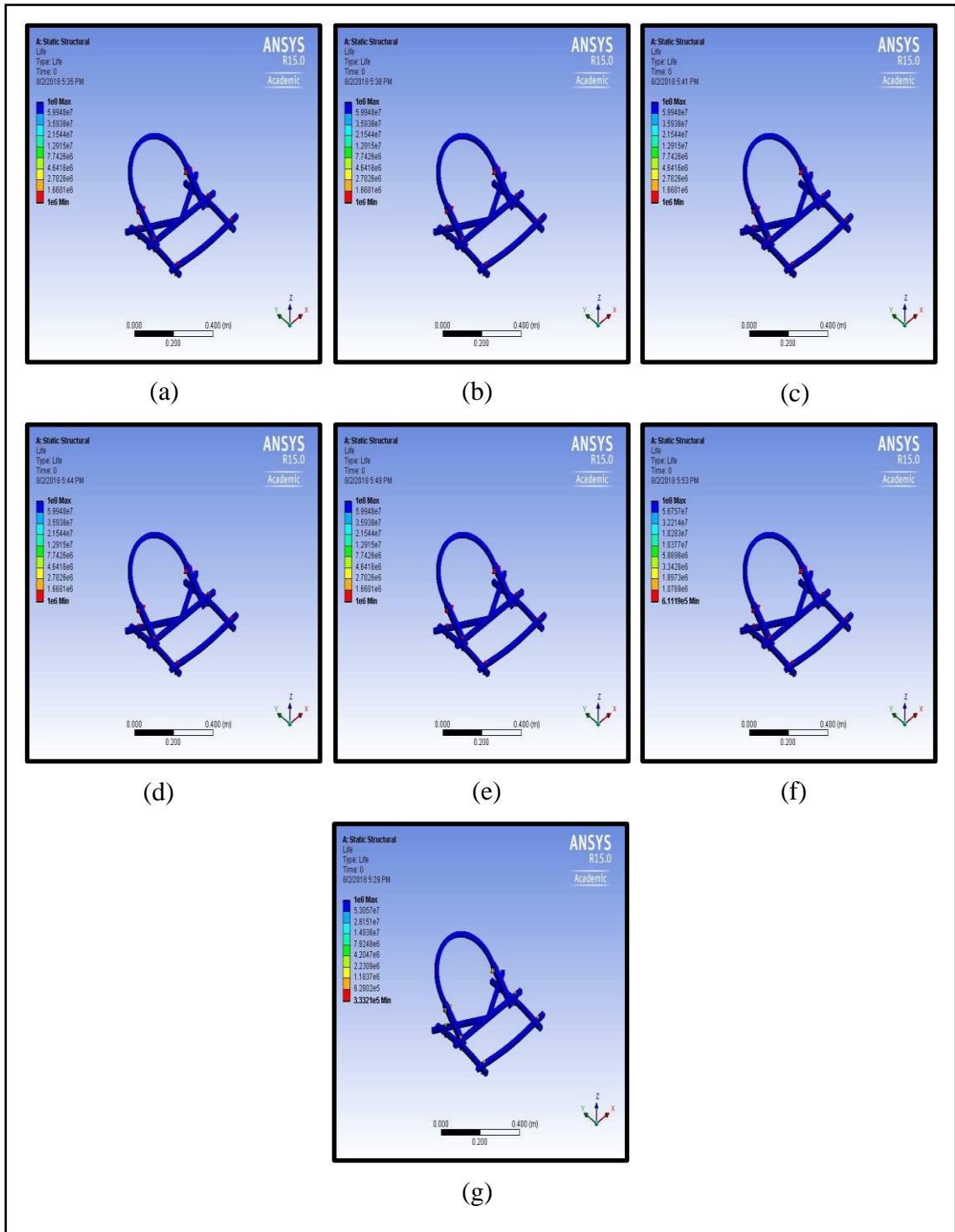

Plate 4.9 Fatigue life of the bottom frame of KAU model at loads of (a) 400 N, (b) 500 N, (c) 600 N, (d) 700 N, (e) 800 N, (f) 900 N and (g) 1000N

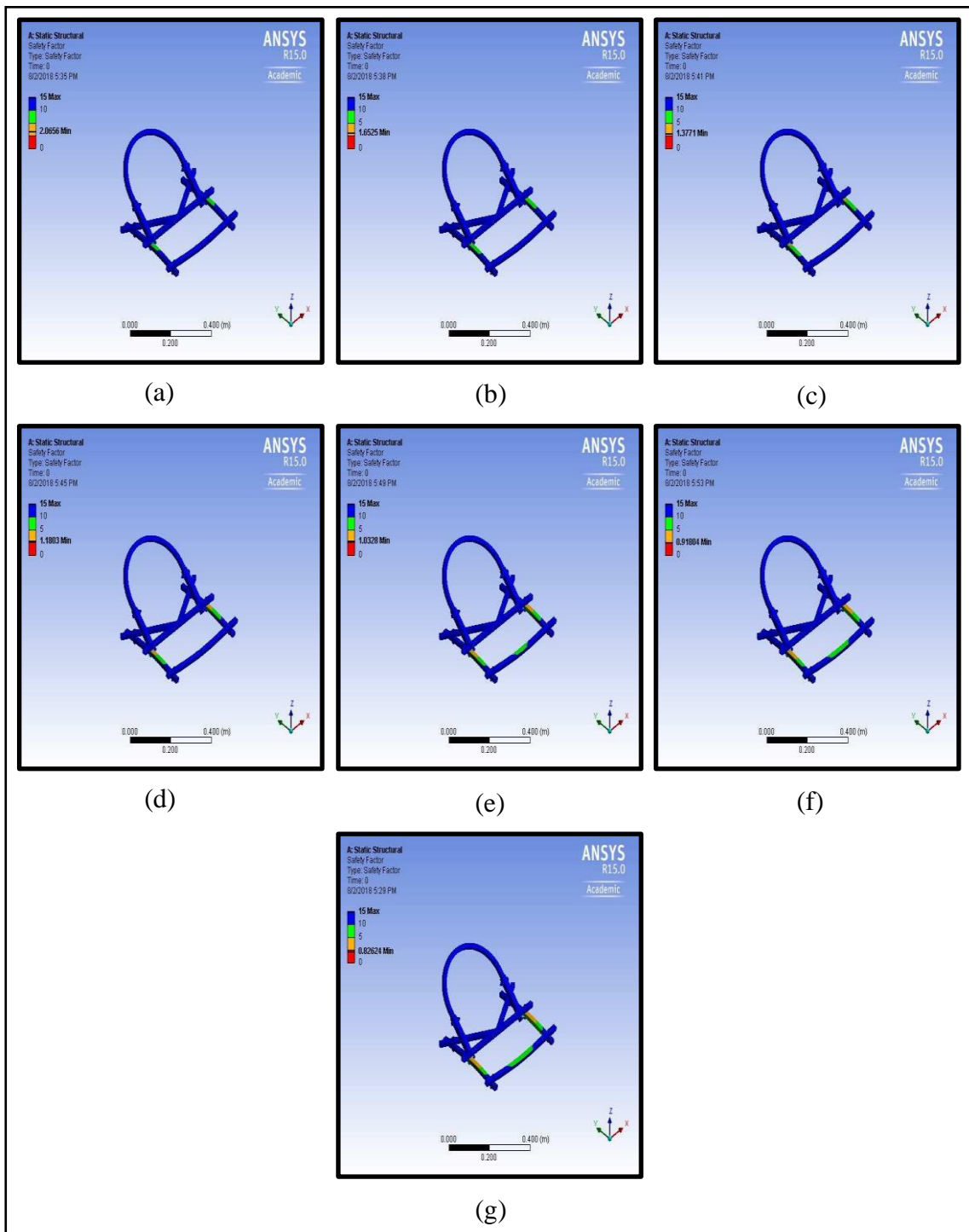

Plate 4.10 Factor of safety of the bottom frame of KAU model at loads of (a) 400 N, (b) 500 N, (c) 600 N, (d) 700 N, (e) 800 N, (f) 900 N and (g) 1000N

Table 4.6 Fatigue analysis of bottom frame of KAU model

Load (N)	Fatigue life (cycles)	Factor of safety
400	1×10^6	2.0656
500	1×10^6	1.6525
600	1×10^6	1.3771
700	1×10^6	1.1803
800	1×10^6	1.0328
900	6.1119×10^5	0.91804
1000	3.3321×10^5	0.82624

The results mentioned in the Table 4.6 show that as the load increased from 400 N to 1000 N the number of cycles are reducing. This indicates that the fatigue life is decreasing. Hence it is presumed that without any failure of the climber the climber can bear infinite fatigue life cycles up to 800 N load, 6.1119×10^5 cycles at 900 N load and 3.3321×10^5 cycles at 1000 N load. The factor of safety was found about 2 with respect to fatigue limit of 86.2 MPa at 400 N load. The minimum fatigue life was observed at spring lock washers, hence it is suggested to change the washers regularly.

4.2 FARMER'S MODEL

4.2.1 Static analysis

The static analysis was carried out separately for top and bottom frames of the Farmer's model at loads of 400, 500, 600, 700, 800, 900 and 1000 N respectively. The equivalent (Von-Mises) stress, equivalent elastic strain and total deformation were found out in the analysis using ANSYS 15.0 software at each load.

4.2.1.1 Top frame

The top frame was made of structural steel. The boundary conditions are fixed as explained in art 3.4.1.1. The meshed model have a total of 50951 elements and 136493 nodes.

4.2.1.1.1 Equivalent (Von-Mises) stress

The material used for fabricating the Farmer's model was structural steel. This is of ductile in nature and so Von Mises stress was observed. The Von Mises stresses of the top frame of the Farmer's model is shown in Plate 4.11 (a) to (g) at various loads of 400,500,600,700,800,900 and 1000 N. A maximum Von Mises stress of 1.5608×10^8 Pa was observed at a load of 1000 N. but the maximum Von Mises stress was only 6.2431×10^7 Pa when the load was 400 N. The maximum Von Mises stress was observed in lock pin and minimum in rope. From the Table 4.7 it is observed that as the load increased from 400 to 1000 N, the Von Mises stress were also increased.

4.2.1.1.2 Equivalent elastic strain

Equivalent elastic strain is the recoverable elastic deformation of a solid if the stress is removed. The equivalent elastic strain of top frame of the Farmer's model is illustrated in plate 4.12 (a) to (g) under loads of 400,500,600,700,800,900 and

1000 N. The maximum equivalent elastic strain at 400 N and 1000 N were 3.138×10^{-4} m/m and 7.845×10^{-4} m/m respectively. The maximum strain occur on lock pin and minimum on rope. From the Table 4.7 it is observed that as the load increased from 400 to 1000 N, the equivalent elastic strain were also increased.

4.2.1.1.3 Total deformation

The total deformation of top frame of the Farmer's model is illustrated in Plate 4.13 (a) to (g) under loads of 400,500,600,700,800,900 and 1000 N. The maximum total deformation at 400 N and 1000 N were 6.8534×10^{-5} m and 1.7133×10^{-4} m respectively. The maximum deformation occur on rectangle plate and minimum on curve plate. From the Table 4.7 it is observed that as the load increased from 400 to 1000 N, the total deformation were also increased.

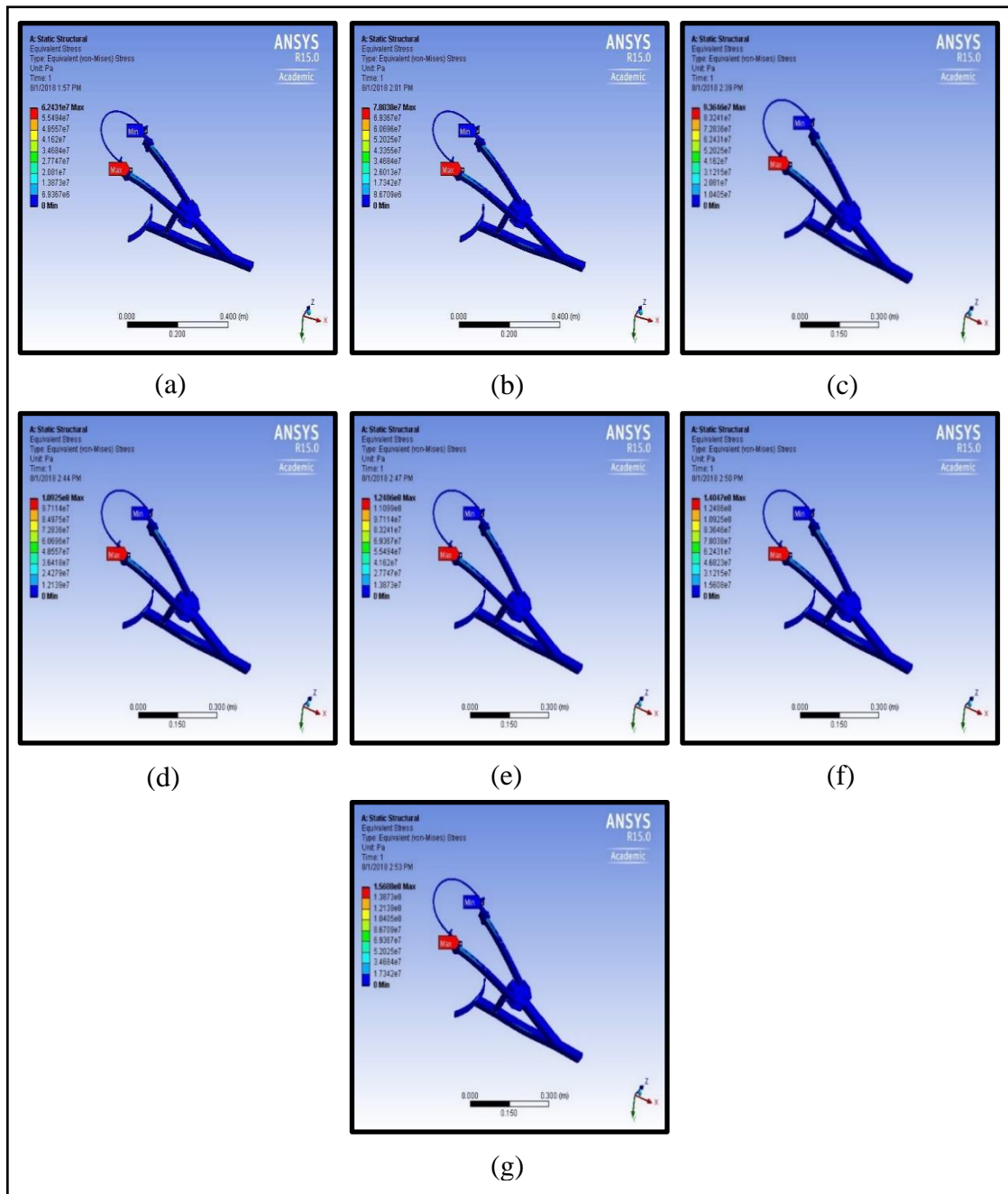

Plate 4.11 Equivalent (Von-Mises) stress of the top frame of Farmer's model at loads of (a) 400 N, (b) 500 N, (c) 600 N, (d) 700 N, (e) 800 N, (f) 900 N and (g) 1000N

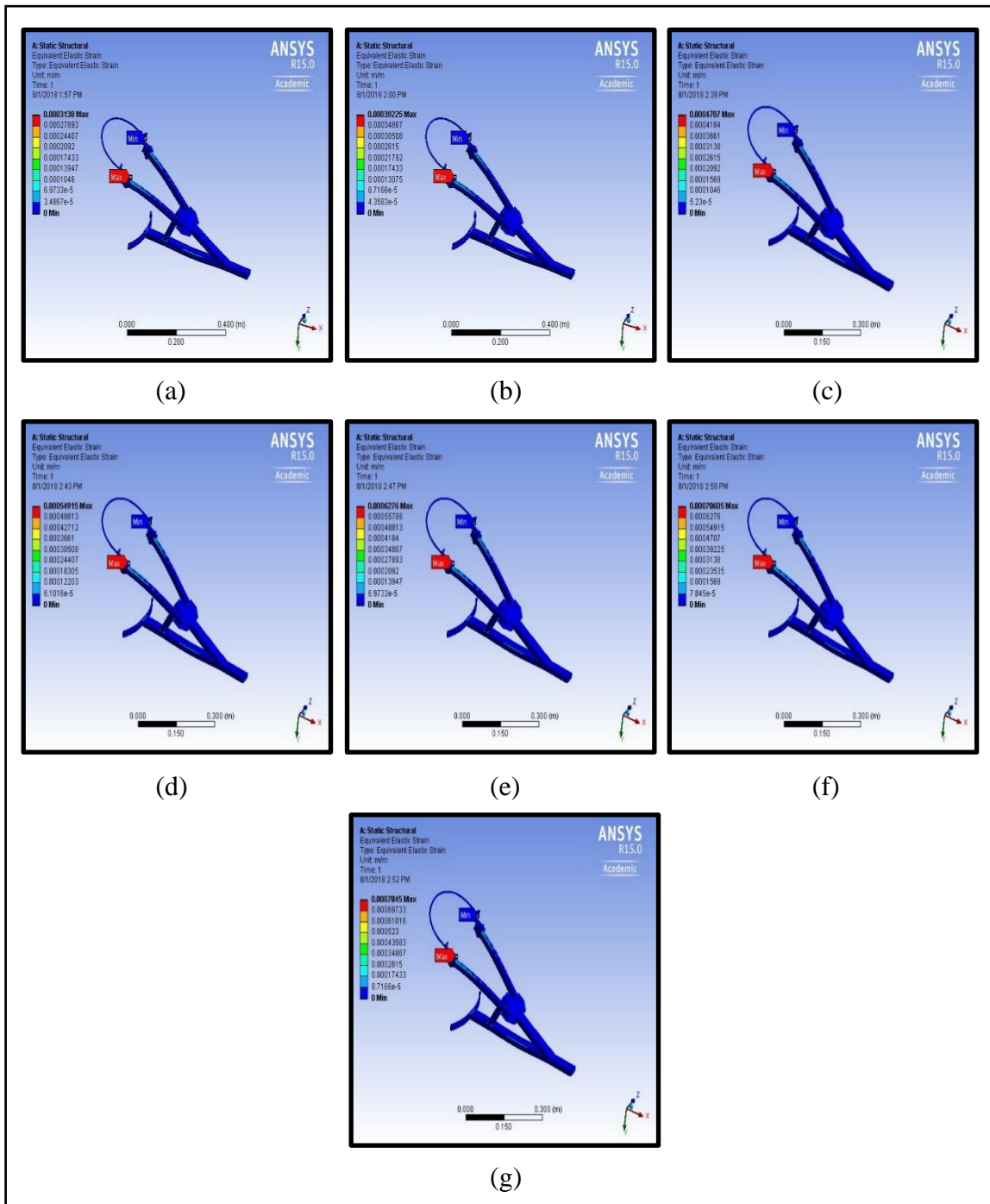

Plate 4.12 Equivalent elastic strain of the top frame of Farmer's model at loads of (a) 400 N, (b) 500 N, (c) 600 N, (d) 700 N, (e) 800 N, (f) 900 N and (g) 1000N

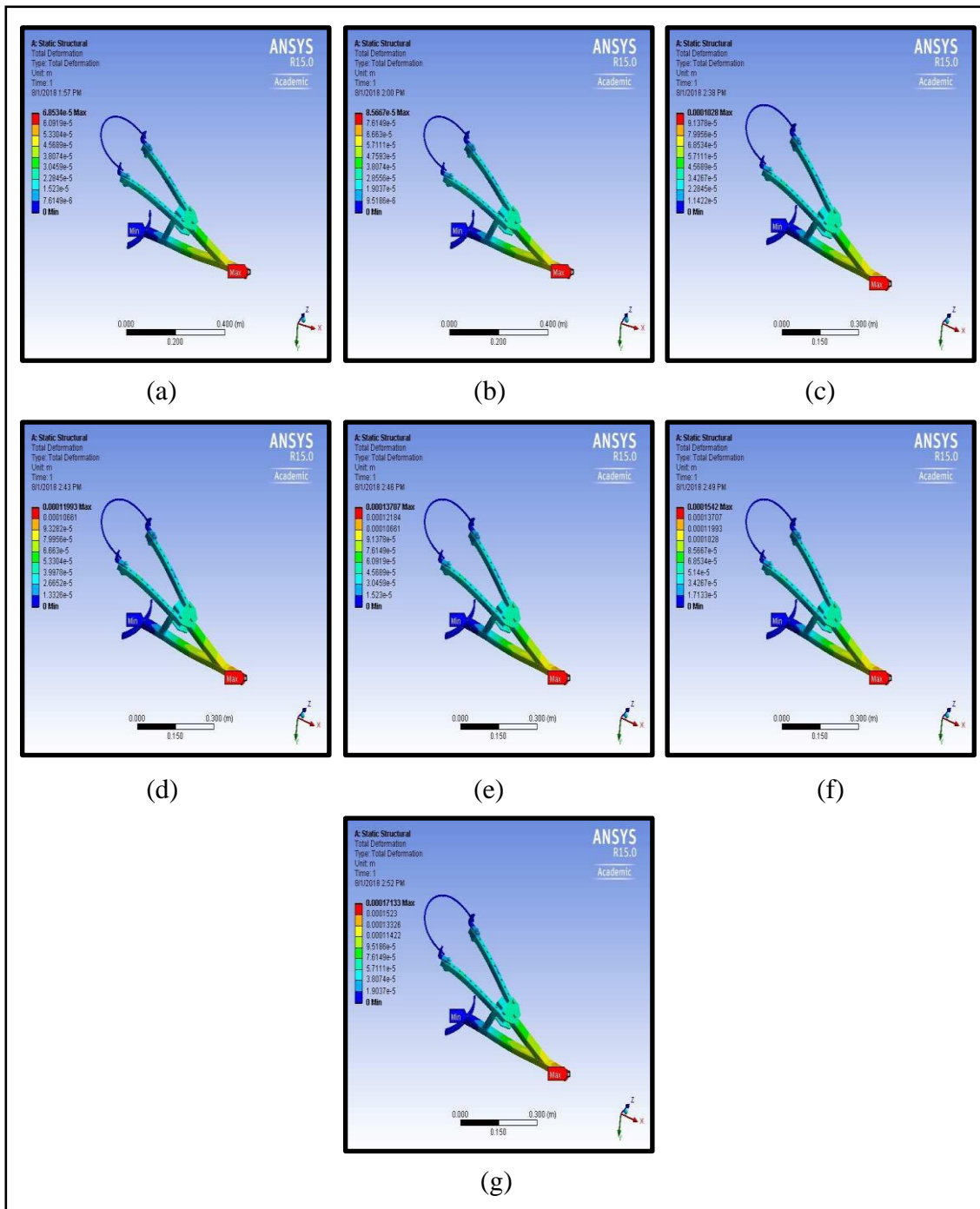

Plate 4.13 Total deformation of the top frame of Farmer’s model at loads of (a) 400 N, (b) 500 N, (c) 600 N, (d) 700 N, (e) 800 N, (f) 900 N and (g) 1000N

Table 4.7 Static analysis of the top frame of Farmer's model

Load (N)	Equivalent (von-Mises) Stress (Pa) (max.)	Equivalent Elastic Strain (m/m) (max.)	Total deformation (m) (max.)
400	6.2431×10^7	3.138×10^{-4}	6.8534×10^{-5}
500	7.8038×10^7	3.9225×10^{-4}	8.5667×10^{-5}
600	9.3646×10^7	4.707×10^{-4}	1.028×10^{-4}
700	1.0925×10^8	5.4915×10^{-4}	1.1993×10^{-4}
800	1.2486×10^8	6.276×10^{-4}	1.3707×10^{-4}
900	1.4047×10^8	7.0605×10^{-4}	1.542×10^{-4}
1000	1.5608×10^8	7.845×10^{-4}	1.7133×10^{-4}

In order to determine the structural safety of the climber under the loads of 400 N to 1000 N, the equivalent (von-Mises) stress values obtained from the static analysis were recorded. The yield strength of the material used in the fabrication of Farmer's model is then taken from the material library of ANSYS 15.0. The factor of safety of top frame of Farmer's model at 400 N to 1000 N loads are given in the Table 4.8.

Table 4.8 Factor of safety of top frame of Farmer's model

Load (N)	Equivalent (Von-Mises) Stress (Pa)	Yield strength of the material (Pa)	Factor of safety
400	6.2431×10^7	2.5×10^8	4
500	7.8038×10^7	2.5×10^8	3.2
600	9.3646×10^7	2.5×10^8	2.7
700	1.0925×10^8	2.5×10^8	2.3
800	1.2486×10^8	2.5×10^8	2
900	1.4047×10^8	2.5×10^8	1.8
1000	1.5608×10^8	2.5×10^8	1.6

The results shown in Table 4.7 and Table 4.8 indicate that, as the load on the climber increased the equivalent (Von-Mises) Stress, equivalent elastic strain and total deformation are also increased. The stress up to 1000 N were less than the yield strength of the structural steel material i.e. 250 MPa. Hence the factor of safety will be > 3 at 400 and 500 N loads, > 2 at 600 and 700 N loads and > 1 at 800 to 1000 N loads. If the factor of safety is more than one then the failure will not take place. The existing top frame of the Farmer's model is not safe to operate under loads of 400 to 1000 N. The maximum stress was observed at lock pin, hence this part have more prone to failure. In order to increase the load bearing capacity provide the double locking system.

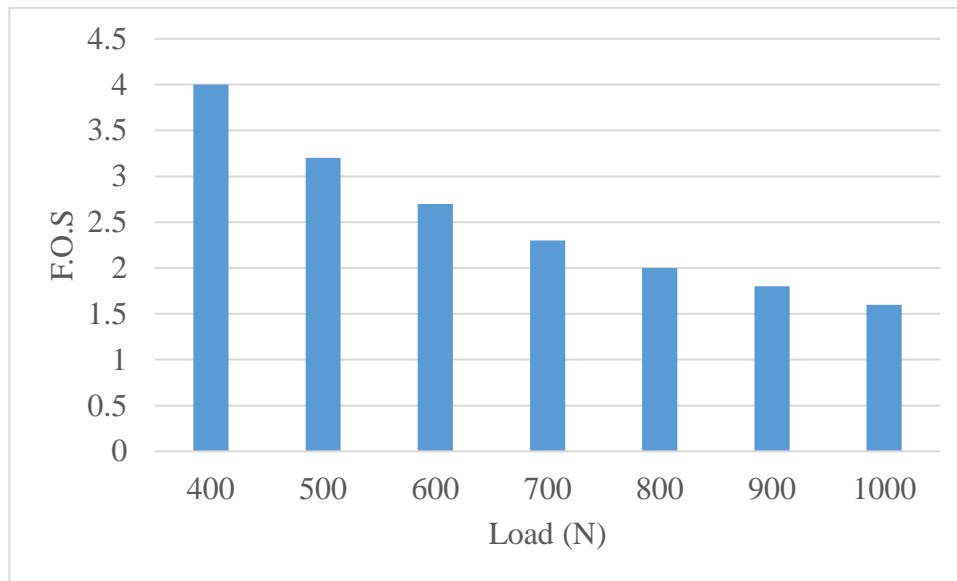

Fig. 4.3 F.O.S of the top frame of Farmer's model (1.5 mm)

4.2.1.2 Bottom frame

The bottom frame is made up of structural steel material. All the boundary conditions were applied to the bottom frame as mentioned in the art. 3.4.1.1 and then analysis was carried out for each load. The meshed model of bottom frame have 52056 elements and 153003 nodes.

4.2.1.2.1 Equivalent (Von-Mises) stress

The material used for fabricating the Farmer's model was structural steel. This is of ductile in nature and so Von Mises stress was observed. The Von Mises stresses of the bottom frame of the Farmer's model is shown in Plate 4.14 (a) to (g) at varies loads of 400,500,600,700,800,900 and 1000 N. A maximum Von Mises stress of 1.9208×10^8 Pa was observed at a load of 1000 N. But the maximum Von Mises stress was only 7.6832×10^7 Pa when the load was 400 N. The maximum Von Mises stress was observed in lock pin and minimum in rope. From the Table 4.9, it is observed that as the load increased from 400 to 1000 N, the Von Mises stress were also increased.

4.2.1.2.2 Equivalent elastic strain

The equivalent elastic strain of bottom frame of the Farmer's model is illustrated in Plate 4.15 (a) to (g) under loads of 400,500,600,700,800,900 and 1000 N. The maximum equivalent elastic strain at 400 N and 1000 N were 3.881×10^{-4} m/m and 9.7025×10^{-4} m/m respectively. The maximum strain occurred on lock pin and minimum on rope. From the Table 4.9, it is observed that as the load increased from 400 to 1000 N, the equivalent elastic strain were also increased.

4.2.1.2.3 Total Deformation

The total deformation of bottom frame of the Farmer's model is illustrated in Plate 4.16 (a) to (g) under loads of 400,500,600,700,800,900 and 1000 N. The maximum total deformation at 400 N and 1000 N were 1.2654×10^{-4} m and 3.1635×10^{-4} m respectively. The maximum deformation occur on bottom frame and minimum on curve plate. From the Table 4.9 it is observed that as the load increased from 400 to 1000 N, the total deformation were also increased.

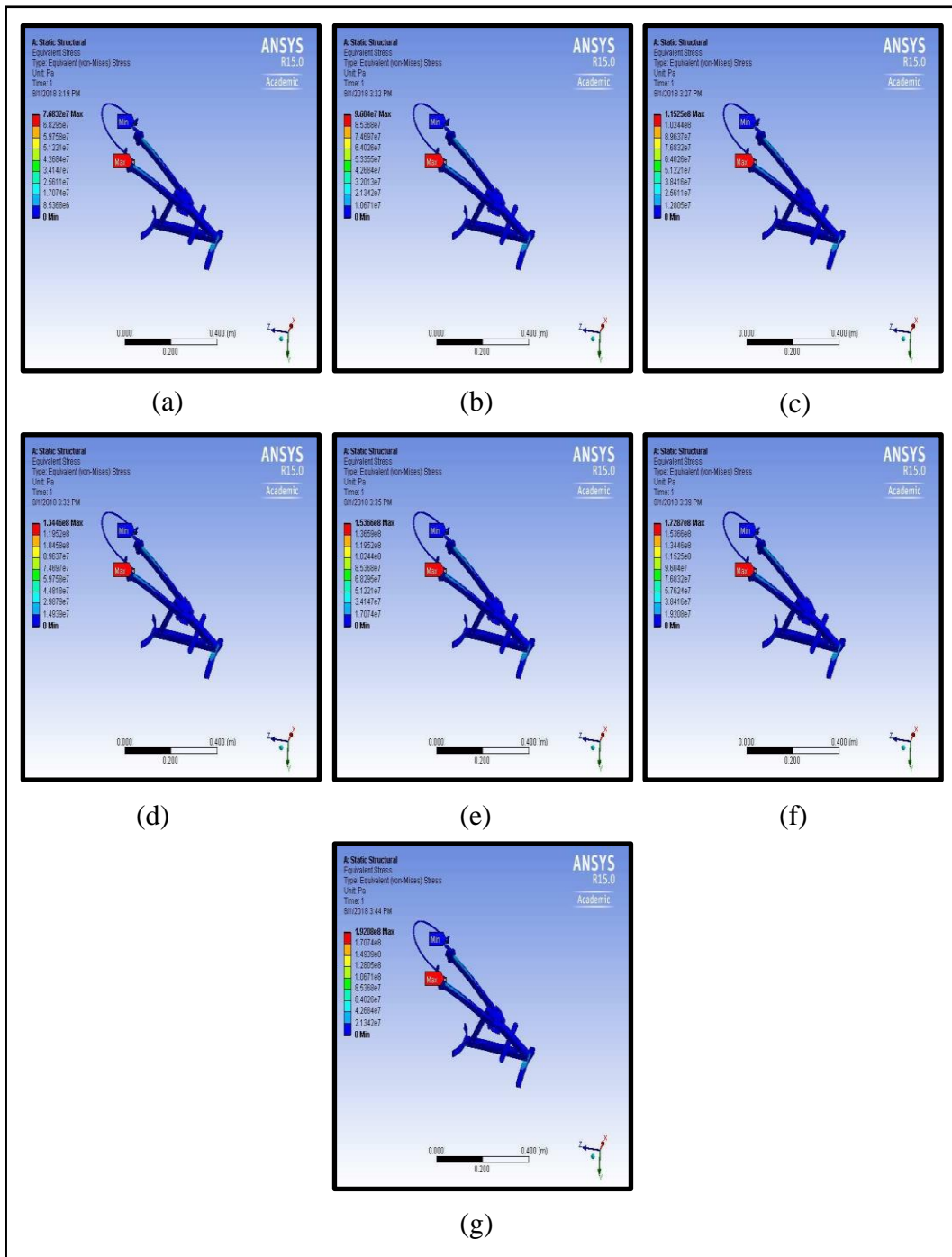

Plate 4.14 Equivalent (Von-Mises) stress of the bottom frame of Farmer's model at loads of (a) 400 N, (b) 500 N, (c) 600 N, (d) 700 N, (e) 800 N, (f) 900 N and (g) 1000N

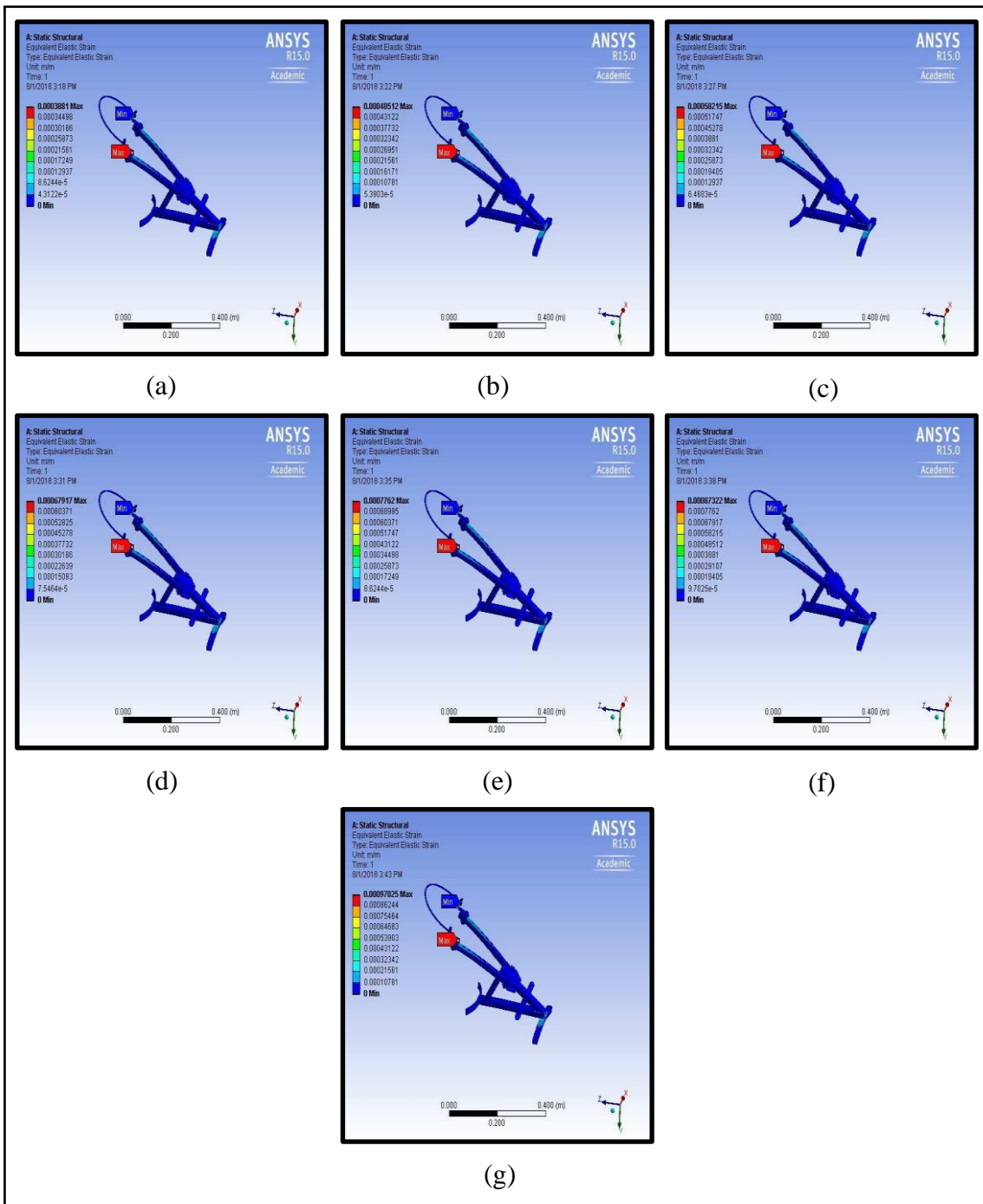

Plate 4.15 Equivalent elastic strain of the bottom frame of Farmer’s model at loads of (a) 400 N, (b) 500 N, (c) 600 N, (d) 700 N, (e) 800 N, (f) 900 N and (g) 1000N

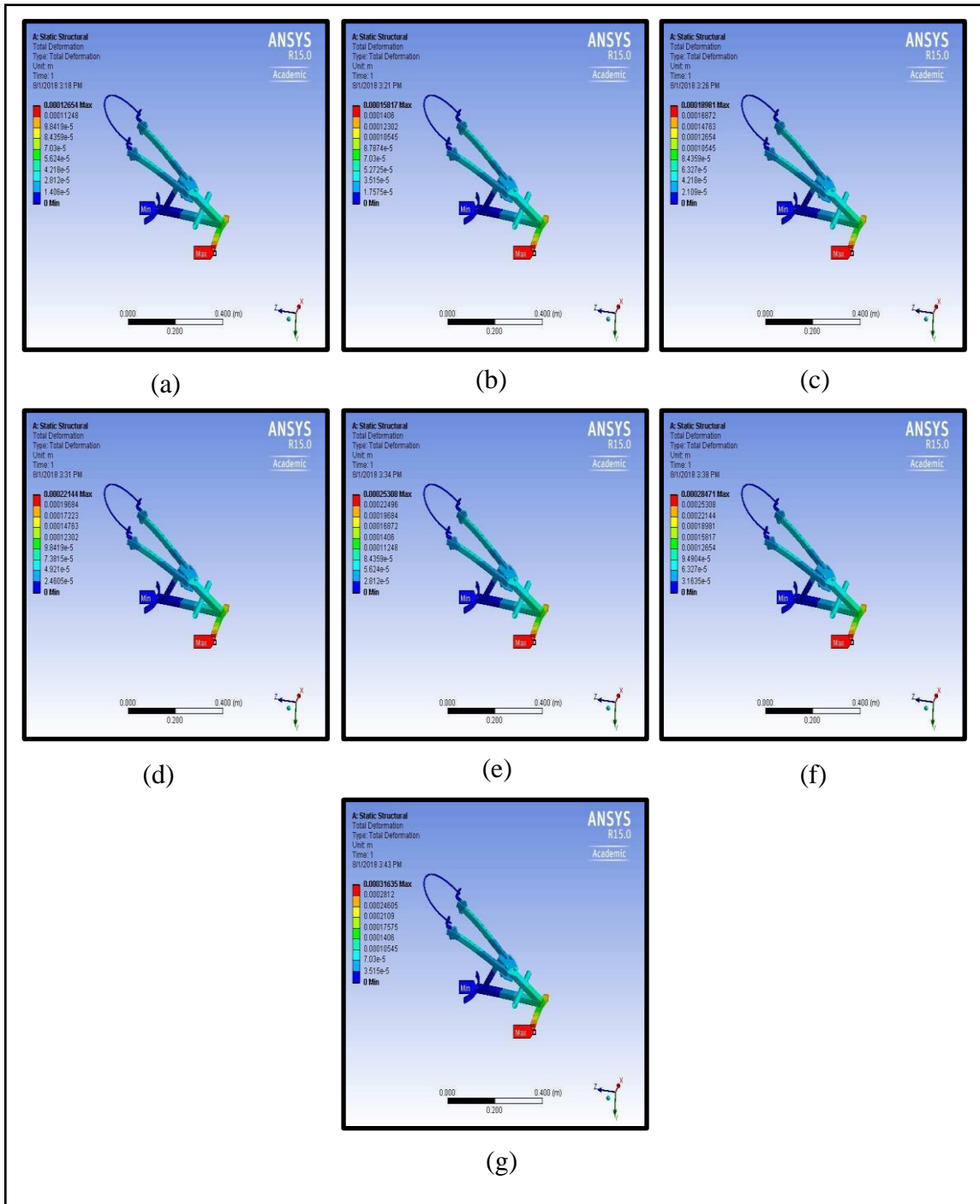

Plate 4.16 Total deformation of the bottom frame of Farmer’s model at loads of (a) 400 N, (b) 500 N, (c) 600 N, (d) 700 N, (e) 800 N, (f) 900 N and (g) 1000N

Table 4.9 Static analysis of the bottom frame of Farmer's model

Load (N)	Equivalent (von-Mises) Stress (Pa) (max.)	Equivalent Elastic Strain (m/m) (max.)	Total deformation (m) (max.)
400	7.6832×10^7	3.881×10^{-4}	1.2654×10^{-4}
500	9.604×10^7	4.8512×10^{-4}	1.5817×10^{-4}
600	1.1525×10^8	5.8215×10^{-4}	1.8981×10^{-4}
700	1.3446×10^8	6.7917×10^{-4}	2.2144×10^{-4}
800	1.5366×10^8	7.762×10^{-4}	2.5308×10^{-4}
900	1.7287×10^8	8.7322×10^{-4}	2.8471×10^{-4}
1000	1.9208×10^8	9.7025×10^{-4}	3.1635×10^{-4}

4.2.1.2.4 Factor of safety

The factor of safety of bottom frame of Farmer's model at 400 N to 1000 N loads are given in the Table 4.10.

Table 4.10 Factor of safety of bottom frame of Farmer's model

Load (N)	Equivalent (Von- Mises) Stress (Pa)	Yield strength of the material (Pa)	Factor of safety
400	7.6832×10^7	2.5×10^8	3.2
500	9.604×10^7	2.5×10^8	2.6
600	1.1525×10^8	2.5×10^8	2.2
700	1.3446×10^8	2.5×10^8	1.8
800	1.5366×10^8	2.5×10^8	1.6
900	1.7287×10^8	2.5×10^8	1.4
1000	1.9208×10^8	2.5×10^8	1.3

The results are given in Table 4.9 and Table 4.10. The results indicate that up to a load of 1000 N the top frame of the Farmer's model is safe to operate because the factor of safety is >1 . The factor of safety will be > 3 at 400 N load, > 2 at 500 and 600 N loads and > 1 at 700 to 1000 N loads. In order to increase the load bearing capacity provide double locking system since the maximum load observed in lock pin.

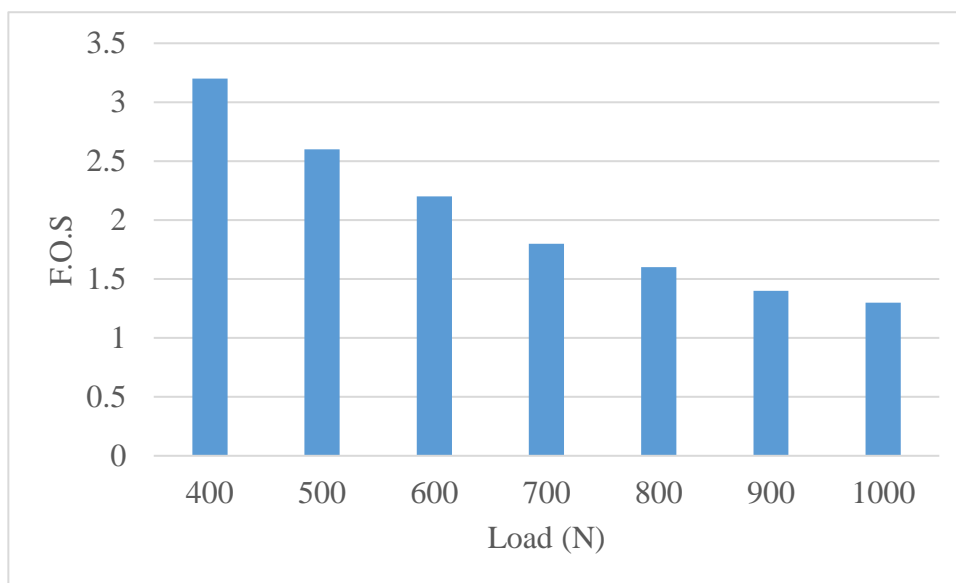

Fig. 4.4 F.O.S of the bottom frame of Farmer's model (1.5 mm)

4.2.2 Fatigue analysis

The fatigue analysis was carried out separately for top and bottom frames of the Farmer's model at loads of 400, 500, 600, 700, 800, 900 and 1000 N. The fatigue life and factor of safety were found out using ANSYS 15.0 software for each load.

4.2.2.1 Top frame

The top frame is made of structural steel. All the boundary conditions were applied to it as explained in art. 3.4.1.1 and the analysis was carried out for each load.

4.2.2.1.1 Fatigue life

Fatigue life is the number of stress cycles that an object or material can handle before failure. The fatigue life of top frame of the Farmer's model is illustrated in Plate 4.17 (a) to (g) under loads of 400,500,600,700,800,900 and 1000 N. The minimum fatigue life at 400 N and 1000 N were 1×10^6 and 1×10^6 cycles respectively. The minimum fatigue life occurs in L plate. From the Table 4.11 it is observed that as the load increased from 400 to 1000 N, the fatigue life decreased.

4.2.2.1.2 Factor of safety (Fatigue)

The factor of safety of top frame of the Farmer's model is illustrated in Plate 4.18 (a) to (g) under loads of 400,500,600,700,800,900 and 1000 N. The minimum factor of safety at 400 N and 1000 N were 2.7615 and 1.1046 respectively. The minimum factor of safety occurs in lock pin. From the Table 4.11 it is observed that as the load increased from 400 to 1000 N, the factor of safety decreased.

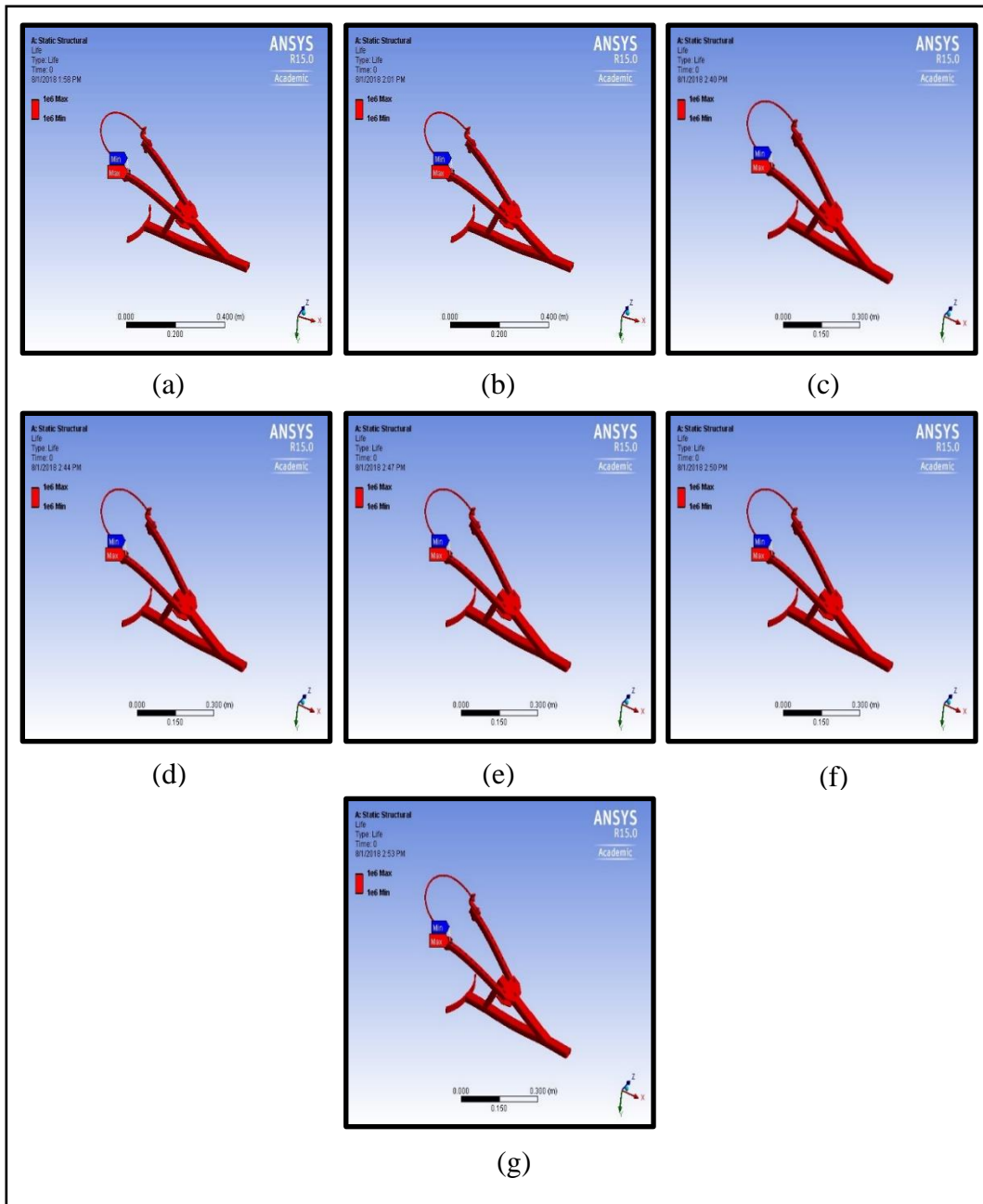

Plate 4.17 Fatigue life of the top frame of Farmer's model at loads of (a) 400 N, (b) 500 N, (c) 600 N, (d) 700 N, (e) 800 N, (f) 900 N and (g) 1000N

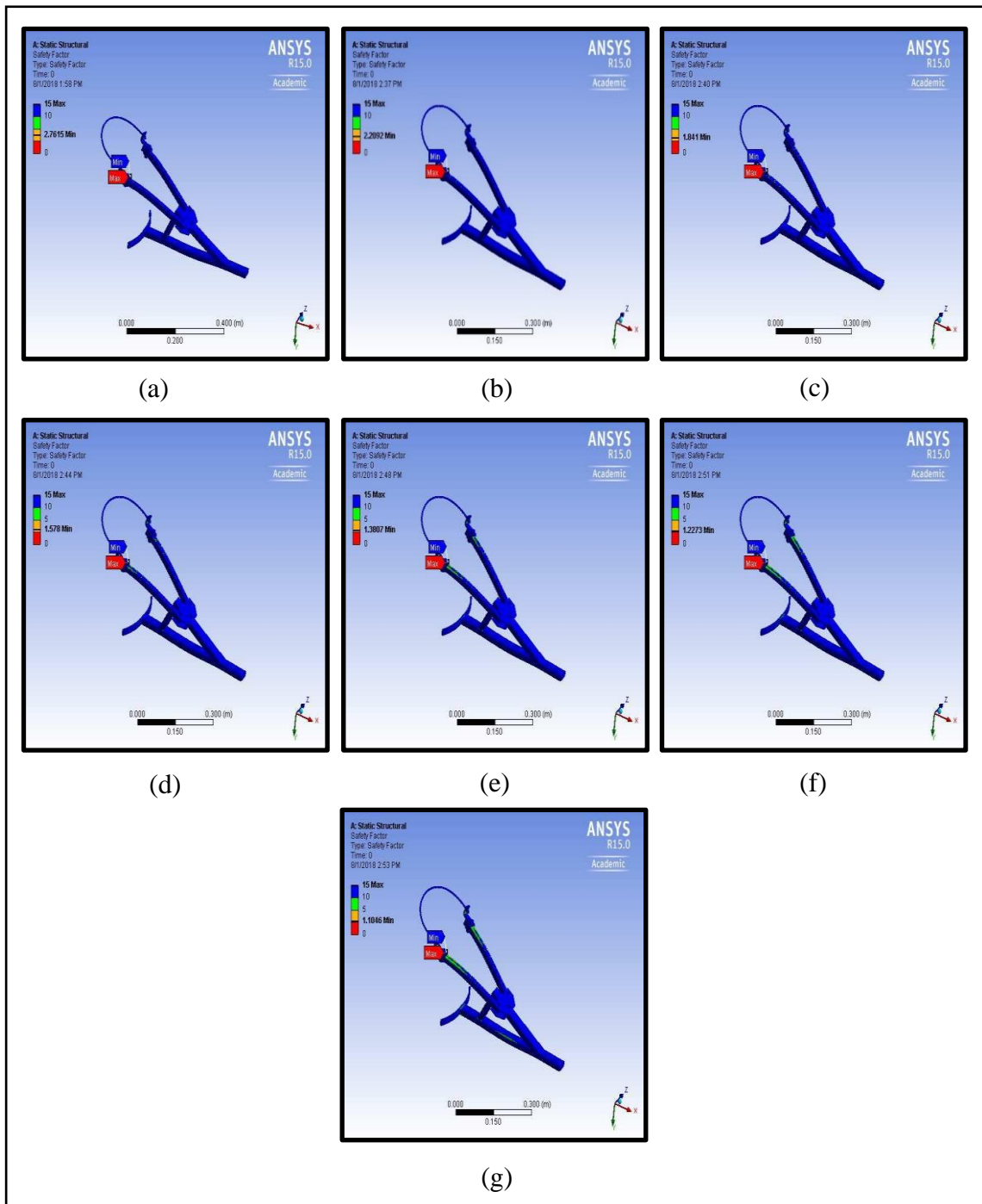

Plate 4.18 Factor of safety of the top frame of Farmer’s model at loads of (a) 400 N, (b) 500 N, (c) 600 N, (d) 700 N, (e) 800 N, (f) 900 N and (g) 1000N

Table 4.11 Fatigue analysis of top frame of Farmer's model

Load (N)	Fatigue life (cycles)	Factor of safety
400	1×10^6	2.7615
500	1×10^6	2.2092
600	1×10^6	1.841
700	1×10^6	1.578
800	1×10^6	1.3807
900	1×10^6	1.2273
1000	1×10^6	1.1046

The results mentioned in the Table 4.11 shows that as the load increased from 400 N to 1000 N the factor of safety was reducing. Hence it is presumed that without any failure of the climber the climber can take infinite life cycles up to 1000 N loads. The factor of safety was found about 2.8 with respect to fatigue limit of 86.2 MPa at 400 N load. In order to increase the fatigue life change the material, design or dimensions of L plate since minimum fatigue life observed in L plate.

4.2.2.2 Bottom frame

The bottom frame is made of structural steel. All the boundary conditions were applied to it as explained in art. 3.4.1.1 and the analysis was carried out for each load.

4.2.2.2.1 Fatigue life

The fatigue life of bottom frame of the Farmer's model is illustrated in Pate 4.19 (a) to (g) under loads of 400,500,600,700,800,900 and 1000 N. The minimum fatigue life at 400 N and 1000 N were 1×10^6 cycles and 15.123×10^5 cycles respectively. The minimum fatigue life occurred in L plate. From the Table 4.12 it is observed that as the load increased from 400 to 1000 N, the fatigue life decreased.

4.2.2.2.2 Factor of safety

The factor of safety of bottom frame of the Farmer's model is illustrated in Plate 4.20 (a) to (g) under loads of 400,500,600,700,800,900 and 1000 N. The minimum factor of safety at 400 N and 1000 N were 2.2439 and 0.89755 respectively. The minimum factor of safety occurred in lock pin. From the Table 4.12 it is observed that as the load increased from 400 to 1000 N, the factor of safety decreased.

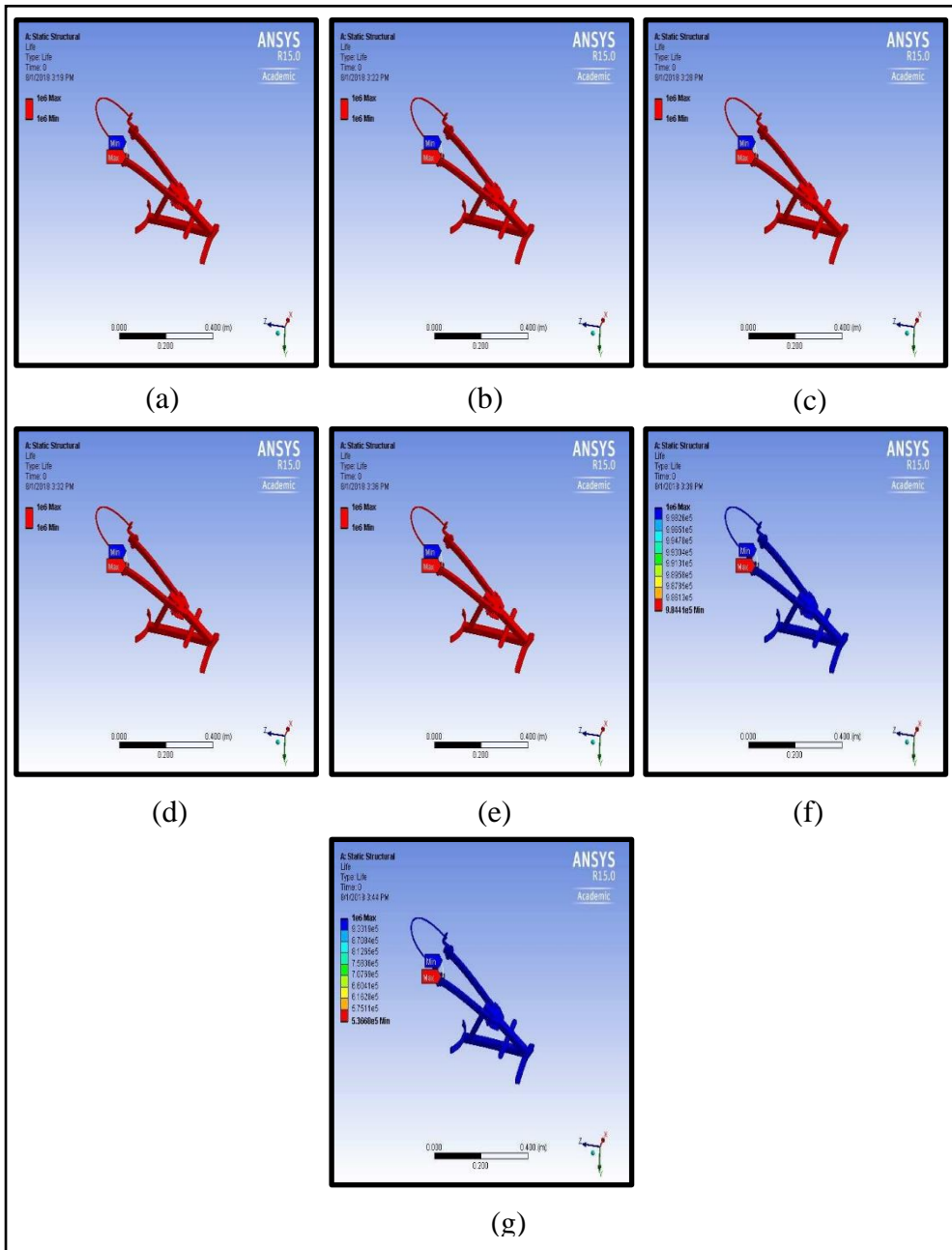

Plate 4.19 Fatigue life of the bottom frame of Farmer’s model at loads of (a) 400 N, (b) 500 N, (c) 600 N, (d) 700 N, (e) 800 N, (f) 900 N and (g) 1000N

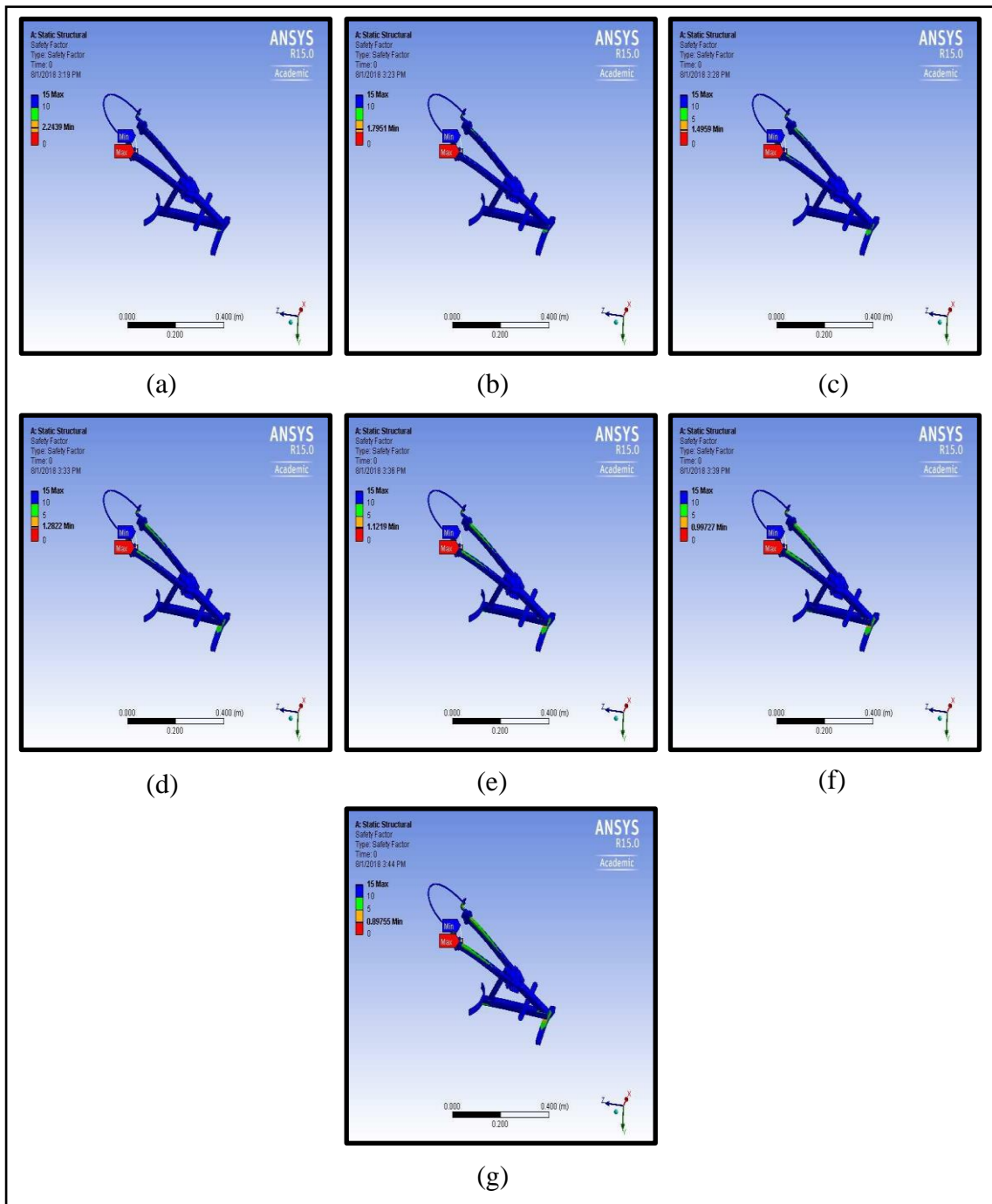

Plate 4.20 Factor of safety of the bottom frame of Farmer's at loads of (a) 400 N, (b) 500 N, (c) 600 N, (d) 700 N, (e) 800 N, (f) 900 N and (g) 1000N

Table 4.12 Fatigue analysis of bottom frame of Farmer's model

Load (N)	Fatigue life (cycles)	Factor of safety
400	1×10^6	2.2439
500	1×10^6	1.7951
600	1×10^6	1.4959
700	1×10^6	1.2822
800	1×10^6	1.1219
900	9.8441×10^5	0.99727
1000	5.3668×10^5	0.89755

The results mentioned in the Table 4.12 show that as the load increased from 400 N to 1000 N the number of cycles are reducing. This indicates that the fatigue life is decreasing. Hence it is presumed that without any failure of the climber the climber can bear infinite fatigue life cycles up to 800 N load, 9.8441×10^5 cycles at 900 N load and 5.3668×10^5 cycles at 1000 N load. As the load increased the number of cycles reduced due to increased stress. The factor of safety was found about 2.2 with respect to fatigue limit of 86.2 MPa at 400 N load. Hence it is suggested to change the dimensions, material and design of the L plate to get more fatigue life.

3.5 DRAFT TEST CODE

The draft test code formulated with view of improvement of mechanical coconut climber in all aspects is given below. Testing includes a determination of functional performance characteristics of machine, durability, wear testing, external forces acting on implement, stresses developed in different parts of implement due to static or dynamic loading.

Draft Indian Standard

MECHANICAL COCONUT CLIMBER- TEST PROCEDURE

The test code and procedure described below are formulated with view for improvement of the design of mechanical coconut climber and better adaptation of mechanical coconut climber, ensuring the good gripping to the trunk, good locking of connecting systems, the strength and stability under different load condition while working and ergonomical safety aspects of the climbing person.

1. SCOPE

This standard covers the following:

1.1 Methods for testing of mechanical coconut climber.

1.2 Assessment of the evaluative requirements applicable for qualifying

minimum performance criteria of the mechanical coconut climber.

1.3 Criteria for determining variants and new model of mechanical coconut climber for the purpose of testing and certification.

2. REFERENCES

The following Indian Standards contain provisions which through reference in this text, constitute provision of this standard. At the time of publication, the editions indicated were valid. All standards are subjected to revision and parties to agreements based on this standard are encouraged to investigate the possibility of applying the most recent editions of the standards indicated:

IS No.	Title
IS	Standard codes on structural steel used in climber
I.S.226:	Structural steel (standard quality)
I.S.808:	Rolled steel beams, channel and angle sections
ASTM 06:	General requirements for delivery of rolled steel plates, sheet piling and bars for structural use
I.S.1367:	Technical supply conditions for threaded fasteners

3. TERMINOLOGY

For the purpose of this standard the following definitions shall apply.

3.1 Confidential test: the test conducted for providing confidential information on the performance of mechanical coconut climber whether ready for commercial production or not, or to provide any special data that may be required by the manufacturer or applicant.

3.2 Commercial test: the tests conducted for establishing performance characteristics of mechanical coconut climber that are ready for commercial production or already in production.

3.2.1 Initial Commercial test: the tests conducted on indigenous or imported prototype of mechanical coconut climber ready for commercial production.

3.2.2 Batch test (conformity of production): the tests conducted on mechanical coconut climber which have already undergone initial commercial test and are

being manufactured/sold commercially in the country. Period of batch test 3 year first and 5 year second and validity of test report will be as per will be subsequently 3 years for first batch and 5 years for second batch.

3.2.3 Repeat test: the tests conducted on mechanical coconut climber, to validate the performance in case of not meeting the evaluative requirements of this standard or to ascertain the re-occurrence of breakdown/defects observed in earlier tests, for the same parameter and on the same sample under the test after rectifying the defects or after replacing the defected part/sub-assembly by new part of the same specifications.

3.2.4 Supplementary test:

(a) Supplementary test is conducted on mechanical coconut climber in case of not meeting the performance requirement after the repeat test. The test is conducted to validate the performance or to ascertain the re-occurrence of the breakdowns or defects observed in repeat test for the same parameter

and on the same sample under test after rectifying the defects or after replacing the defected part by new part of same specifications or revised specifications with improved design, or on fresh sample of same specifications or revised specifications with improved design.

And/or

(b) the tests conducted on mechanical coconut climber for certain parameters or improvements such as suitability for all coconut trees or other modifications desired by the manufacturer after incorporating the improvements which shall be incorporated permanently on mechanical coconut climber model which had already undergone Initial Commercial Test.

3.2.5 Evaluative requirements: requirements under this category are the ones which are mandatory for acceptance of the mechanical coconut climber for the purpose of commercial production or subsidies or financing. The testing agency will assess the performance of the mechanical coconut climber under test and release the report.

3.3 Non Evaluative requirements: requirements under this category are the ones which are not mandatory for acceptance of the mechanical coconut climber for the purpose of commercial production or subsidies or NABARD financing. However, the authorized testing

agency may observe the performance for these requirements and record in the test report.

3.4 Terminology:

Following terminologies related to mechanical coconut climber shall apply

3.4.1 Tree climber: is built to solve the problems man faced with climbing. The climber could take load on and off the tree.

3.4.2 Top frame: it is the unit fitted on the coconut tree, was operated by hand and provided with seating arrangement.

3.4.3 Bottom frame: it is a supporting unit fitted on the tree. Operated by hand and provided with seating arrangement.

3.4.4 Steel wire rope: it will connect the top and bottom frames arms together to hold the tree. It will undergo tension when person sit and stand.

3.4.5 Foot rest: it is the provision for the person to place foot and help in lifting the bottom frame by the foot itself.

3.4.6 Safety belt: to hold the person for his safety against any falling accidents take place while climbing.

3.4.7 Lock and lock pin: the wire rope is loop into the arms by means of lock and lock pin.

3.4.8 Capacity of the climber: it refers to the number of trees climb up and down in unit time.

3.4.9 Setting up climber: it refers to the preliminary attachment of coconut climber to the coconut tree.

3.4.10 Oxygen consumption: oxygen consumption refers to the capacity of the cardiopulmonary system to absorb sufficient oxygen needed to perform and sustain workout sessions.

3.4.11 Heart beats of climber: the number of heartbeats per unit of time, usually per minute while climbing up and down the tree.

3.4.12 Height of tree: it refers to the height of the tree from the bottom to crown of the coconut tree.

3.4.13 Trunk perimeter of tree: it refers to the circumference of the coconut tree trunk or diameter of the trunk.

4. GENERAL GUIDELINES

4.1 Selection: For commercial test the mechanical coconut climber shall be selected at random from the production line or as directed by the testing authority. The mechanical coconut climber shall be complete with all its usual accessories and in condition generally offered for sale. The mechanical coconut climber shall be new and should not give any special treatment or preparation for test. The manufacturer may submit

prototype for confidential test report. The nature of test shall be stated by the manufacturer.

4.2 Specification sheet: The manufacturer or applicant shall supply the specification of the mechanical coconut climber consisting of the items listed in the specimen report given in ANNEX A, as well as any other information required by the testing authority to carry out the tests.

The manufacturer or applicant should also supply technical literature such as operational, maintenance and service manuals, and parts catalogue.

4.3 Running-in: The manufacturer or applicant shall run in the climber before test under his responsibility and in accordance with his usual instructions. The running-in shall be carried out in collaboration with the testing authority or the procedure agreed to with the manufacturer or applicant. After running-in, service and preliminary settings should be done according to the printed literature supplied by the manufacturer/ applicant.

4.3.1 The place and duration of running-in shall be reported.

4.4 Servicing and preliminary setting after running-in

4.4.1 After completion of running-in servicing and preliminary settings should be done according to the printed literature supplied by

the manufacturer / applicant. The following may be carried out wherever applicable:

- a) Tightening the nut and bolts
- b) Checking and adjusting the lock mechanism and base plate friction force
- c) Checking and adjustment of safety attachments if any and
- d) Any other checking or adjustment.

Recommended by the manufacturer after the running-in period and included in the printed literature of the mechanical coconut climber

4.4.2 The manufacturer/applicant may make adjustments as specified by the manufacturer/applicant for agricultural use in the printed

literature/specification sheet. No adjustment shall be made, unless it is recommended in the literature. All the parts replaced shall be reported in the test report.

4.5 Repairs and adjustments during tests: all the repairs and adjustments made during the tests shall be reported together with comments any practical defects or shortcomings.

5. TESTS

Various tests to be conducted on mechanical coconut climber are given in Table 1.13 The implementing authority shall decide about the tests and their frequency to be carried out during initial commercial and batch testing (see 3.2 and 3.2.2)

Table 4.13 Tests to be conducted on mechanical coconut climber

Sl. No.	Tests	Ref. to	Remarks
i)	Checking of specification		
ii)	Performance test & Ergonomic evaluation		
iii)	Strength and stability test		
vi)	Components/assembly inspection		
vii)	Special characteristics		

6. CHECKING OF SPECIFICATIONS

6.1 The information given by the manufacturer or the applicant in the specification sheet (see 4.2) shall be verified by the testing

authority and reported. Details of the components and assemblies which do not conform to the relevant Indian Standards shall also be reported. The adequacy or

otherwise of the literature shall be indicated.

6.2 The checking the dimensions of the mechanical coconut climber, the conditions laid down in the 4.2 shall be followed.

7. PERFORMANCE TEST

7.1 The selection of area to conduct the test of mechanical coconut climber.

7.1.1 Selection of area: The area selected for the test shall be a coconut plantation farm and selecting the tree randomly.

7.1.2 Preparation of mechanical coconut climber for tests.

7.1.2.1 The mechanical coconut climber should be fitted with accessories in accordance with the manufactures or applicants recommendations. The servicing and maintenance shall be carried out in accordance with the schedule prescribed by the manufacturer / applicant in the printed literature.

7.1.2.2 The test shall be conducted in optimum settings as recommended by the manufacturer which is based on tree trunk characteristics and type of person climbing the tree for satisfactory operation. The safety of the operator shall be ensured.

7.1.2.3 During and after the operation, the data or observations shall be recorded.

7.1.2.4 The stoppage, breakdown or defects, ease of operation and difficulties occurred during the operation shall be reported.

7.1.2.5 After completion of field performance test the readings shall be reported with D-1

8. ERGONOMICAL TEST

The readings of heart rate, oxygen consumptions of climbing persons were taken before and after climbing the tree. Anthropometric dimensions are also need to record

The data shall be reported in D-2

9. STATIC ANALYSIS

The static analysis of climbers has to carry out in any FEM software and the equivalent stress (Von-Mises), equivalent elastic strain, total deformation, fatigue life and factor of safety were analysed.

The data shall be recorded in data sheet D-3

10 COMPONENT / ASSEMBLY INSPECTION

10.1 The wire rope and arm looping, locking system, top and bottom links, shoulder plate shall be dismantled after conducting all the tests.

The following measurement or observations shall be made and reported.

10.2 wire-rope: the wire rope shall be removed and inspected for damage or wear.

10.3 lock and lock pin system: the lock and lock pin system shall be dismantled and inspected for damage or wear.

10.4 arms: the damage or breakage of arms shall be inspected and reported.

10.5 top frame: the damage or break of top frame shall be inspected and reported.

10.6 bottom frame: the damage or break of bottom frame shall be inspected.

10.7 shoulder plate: the shear damage of the plate inspected.

10.8 K-frame: the frictional damage to the k-frame shall be inspected.

10.9 U-frame: the frictional or tension damage to the U frame shall be inspected.

10.10 welding's: the failure of welding's shall be inspected

The data shall be reported in D-4

11 LABORATORY STRENGTH TEST

The laboratory strength test has to conduct to know about tension, compressive, bending, shear and fatigue strength of the climbers.

The data shall be recorded in data sheet D-5

12 ACCEPTANCE CRITERIA FOR PERFORMANCE CHARACTERISTICS

12.1 The product may be accepted for performance after confirming compliance to all evaluative requirements. Performance characteristics of mechanical coconut climber along with the tolerances with respect to the declared values and in certain cases minimum / maximum values are given in Table 4.14.

NOTE: In case of a parameter not meeting evaluative requirements of this standard, the 'Repeat Test' as defined above may be conducted. In case the parameter not meeting the evaluative requirement during the Repeat Test, Supplementary Test as defined above may be conducted.

13 ACCEPTANCE CRITERIA IN CASE OF BREAKDOWNS / DEFECTS

13.1 The product may be accepted subject to the following conditions:

- a) There is no 'critical breakdown' during its validation after all tests including repeat or supplementary tests
- b) There are not be major breakdown and
- c) There are not more than one 'minor defects' during the test

NOTE: In case more than one minor defects the 'Repeat Test' as defined above may be conducted.

In case reoccurrence of breakdowns or defects during the repeat test, supplementary test as defined above may be conducted.

13.2 In case of multiple consequential failures resulting from a single defect or breakdown, the primary single defect or breakdown shall only be counted.

13.3 Categorizations of defects in terms of 'critical', 'major' and 'minor' for various sub-assemblies/parts are provided in the **ANNEX-B**.

14 GUIDELINES FOR SUPPLEMENTARY TEST

12.1 In case the fresh sample is required for carrying out supplementary test, the model will have to be ascertained as being the same model as tested earlier (under initial commercial test) by the following checks:

a) Specification in full

14.2 In case of request received for supplementary test for certain parameters of the sample, the Testing Authority may carry out other relevant test(s) also in consultation with the applicant.

If a sample is accepted for supplementary test and during test period or subsequently (before release of test report), it is found not being the same model as tested earlier under ICT, the further test on the sample would be asked to withdraw the sample from test. However, incomplete test report, on tests, already carried out, shall be released under commercial test.

Table 4.14 Minimum performance standard (MPS)

Sl No .	Characteristics		Category (Evaluative / Non-evaluative)	Requirement	Tolerance
1	Strength parameters				
	a	Tensile strength	Evaluative		
	b	Compressive strength	Evaluative		
	c	Shear strength	Evaluative		
	d	Fatigue strength	Evaluative		
	e	Yield strength	Evaluative		
	f	Impact strength	Evaluative		
2	Equipment parameters				
	a	Maximum weight	Evaluative		
	b	Total length	Evaluative		
	c	Total width	Evaluative		
3	Performance parameters				
	a	Time for setting up. (Min)	evaluative		
	b	Time for removing. (Min)	evaluative		
	c	Number of cycles to cover one tree. (cycles)	Evaluative		
4	Field requirements				
	a	Trunk covering ability, under variation in trunk diameter from one tree to another	Evaluative		
	b	Adjustability under variation in inclination of tress from vertical, degrees	Evaluative		
5	Ergonomical parameters				
	a	Heart rates (beats/min)	Men	Evaluative	
			Women	Evaluative	
	b	Oxygen consumption (ml/kg/min)	Men	Evaluative	
			Women	Evaluative	

	c	Anthropometric dimensions			
		Weight	Evaluative		
		Stature	Evaluative		
		Vertical reach	Evaluative		
		Vertical grip reach	Evaluative		
		Elbow height	Evaluative		
		Hip breadth	Evaluative		
		Arm reach from the wall	Evaluative		
		Hand grip length	Evaluative		
		Age	Evaluative		
		Knee height sitting	Evaluative		
		Hand length	Evaluative		
		Palm length	Evaluative		
		Foot length	Evaluative		
		Foot breadth	Evaluative		
6		Static analysis parameters			
	a	Total deformation	Evaluative		
	b	Equivalent elastic strain	Evaluative		
	c	Equivalent stress (Von-Mises)	Evaluative		
	d	Fatigue life	Evaluative		
	e	Factor of safety (fatigue)	Evaluative		

Table 2 - continued

Sl No.	Characteristic		Category (Evaluative/ Non-evaluative)	Requirement	Tolerance
7	Safety Requirements:				
	a	Provision of double locking system	do	yes	--
	b	Provision of safety belt	do	yes	--
	c	Provision of connecting rope	do	yes	--
	d	Covers foot rest with cushioning material	do	yes	--

8	Literature (submission to test agency):				
	a	Operator manual	Evaluative	Provide	
	b	Parts catalogue	Evaluative	Provide	--
	c	Workshop/service manual	Evaluative	Provide	--
9	Labelling of equipment (provision of labelling plate) should be permanent, insert separate chapter				
	a	Name of equipment	Evaluative	Metallic plate shall be welded permanently on the equipment at place where it can be easily identified	
	b	Name & Address of the manufacturer	Evaluative		
	c	Model	Evaluative		
	d	Year of manufacture	Evaluative		
	e	Details of time required	Evaluative		
	f	Capacity of the equipment	Evaluative		

ANNEX - A

SPECIFICATIONS SHEET	
GENERAL	
Name and address of manufacturer	
Name & address of applicant	
Country of origin	
If imported C.I.F. value	
Selling price in India	
Selling price in Country of origin	
Selected by	
Method of selection	
TECHNICAL SPECIFICATION	
Make	
Model	
Type	
Serial number	
Serial number of 1 st prototype	
Year of manufacture	
WIRE ROPE	
Number	
Material of manufacture	
Method of making	
Method of adjusting	
Method of tensioning	
Type	
Length	
Diameter	
BASE PLATE	
Arc	
Length	
Method of mounting	
Surface roughness	
SHOULDER PLATE	
Material	
Dimensions	
No of holes	
Hole diameter	
ARMS	
Material	
Dimensions	
No of holes	
LOCK AND LOCK PIN	
Material	
Dimensions	

Shearing force acted upon it	
U FRAME	
Material	
Dimensions (L×B×D)	
K FRAME	
Material	
Dimensions (L×B×D)	
SEAT	
Material	
Dimensions	
TOP FRAME	
No of parts	
Material of manufacture	
Brief description	
Type of mechanism	
Adjustment	
BOTTOM FRAME	
No of parts	
Material	
Type of mechanism	
Adjustment	
Brief description	
FOOT REST AND FOOT HOLDER	
Material	
Dimensions	
Brief description	
OVERALL DIMENSION	
Length	
Width	
Height	
Total Weight	
Colour	

Overall dimensions

Length (mm):

Width (mm):

Height (mm):

List of other accessories supplied with climber

- 1.
- 2.
- 3.
- 4.

Procedure for arrangement of equipment:

Place:

Signature:

Date:

designation:

Any other specific recommendations:

Place:

Signature:

Date:

Name:

Designation:

**CATEGORIES OF BREAKDOWNS / DEFECTS (Critical
breakdowns, major breakdowns, minor breakdowns)**

Critical breakdowns	
Locking pin	Shearing out
Wire rope	tearing
U frame	breaking
Major breakdowns	
Base plate	Deformation
K frame	Deformation
Clamps	Breakdowns
Arms	Bending
Minor breakdowns	
Side bars	bending

FIELD PERFORMANCE TEST OF MANUAL COCONUT TREE CLIMBER

Test No		Test starting time		Place of test	
Date		Test finishing time		Name, variety & Age of Tree	
Name of Supervisor & staff		Make & model of machine			Max. Dia of Tree
				Bottom/Top	
Name of operator		Type of work			

Sl.No	Dia. Of climbing tree bottom/top	Time taken for climbing the tree (sec)	Time taken for downing/ lowering the tree (sec)	Time taken for installing the climber on the tree (sec)	Time taken for removing the climber from the tree (sec)	Time taken for inter changing the tree (sec)	Height of coconut tree (mts)	Height of plucking coconut bunches from operator (cm)	1.Operator Details	
									-oxygen consumption -heart rate -anthropometric dimensions	
									2. Total duration of Test (h)	
									3. Total stoppage(h)	
1									4. Net run hours(h)	
2									5. No. of coconut tree climb	
3									6. Total Nos. of coconut plucking per hour	
4									7. coconut plucking capacity per hour	

5									8.100 coconut plucking time(h)	
Total									9. Safety & comfort	
Avg										
11. Tree surface condition										
13. Rope slippage during the Test										

Stoppage:

<p>(A)Condition of orchard:-</p> <p>-Type and variety of coconut tree</p> <p>-Age of tree</p> <p>-Height of tree</p> <p>-Topography of field:</p>		<p>(B)Condition of Coconut tree climber:-</p> <p>1.Handling easiness</p> <p>2.Operator climbing comfort</p> <p>3.Suitability of machine</p> <p>4.Defects &breakdowns if any</p>	
--	--	--	--

<p>(C) Ease of operation & adjustments:-</p> <p>(a) Whether the equipment balanced during operation?</p> <p>(b) Any slippage rope during the test</p> <p>(c) Is there any deformation and breakage of parts noticed during the test?</p>		<p>(D) Operator's Details</p> <p>oxygen consumption</p> <p>-heart rate</p> <p>-anthropometric dimensions</p>	
---	--	---	--

Technician

Test Engineer

HEAD, FMTC

DATA SHEET OF ERGONOMIC TEST

Heart rates (beats/min)	Men	
	Women	
Capacity (trees/hr)		
Oxygen consumption (ml/kg/min)	Men	
	Women	
Anthropometric dimensions		

DATA SHEET OF STATIC ANALYSIS

Total deformation (mm)	
Equivalent elastic strain (mm/mm)	
Equivalent stress (Von-Mises) MPa	
Fatigue life (cycles)	
Factor of safety (fatigue)	

COMPONENTS / ASSEMBLY INSPECTION

The top frame and bottom frame shall be dismantled after conducting all the tests. The following measurement or observations shall be made and reported.

Lock pin: lock pin shall be dismantled and inspected for damage or wear

Base plate: Base plate shall be dismantled and inspected for damage or wear

Wire rope: Wire rope shall be dismantled and inspected for damage or wear

Arms: Arms shall be dismantled and inspected for damage or wear

U frame: U frame shall be dismantled and inspected for damage or wear

K frame: K frame shall be dismantled and inspected for damage or wear

Side bars: Side bars shall be dismantled and inspected for damage or wear

Inserting tubes: Inserting tubes shall be dismantled and inspected for damage or wear

Body frame: Body frame shall be dismantled and inspected for damage or wear

DATA SHEET OF COMPONENTS / ASSEMBLY INSPECTION

The top frame and bottom frame shall be dismantled after all the tests for 25 hours at the Institute.	
lock pin	
Base plate	
Wire rope	
Arms	
U frame	
K frame	
Side bars	
Inserting tubes	
Body frame	

DATA SHEET OF LABORATORY STRENGTH TEST

Tensile strength (N)	
Compressive strength (N)	
Shear strength (N)	
Fatigue strength (N)	
Yield strength (N)	
Impact strength (N)	

CHAPTER V

SUMMARY AND CONCLUSIONS

Coconut palms are unbranched evergreen trees cultivated mainly for its nuts. The operations like harvesting of nuts and spraying pesticides need to be carried out at the crown, which requires labours to climb up the tree. Climbing of palm has been identified as laborious, hazardous, tedious and risky job. In order to make this job easy and to help the farmers in this regard, mechanical coconut climbers were developed. The available coconut climbers include TNAU', 'KCAET (KAU)', 'Kera Suraksha (ARS)' 'Chemberi' and 'Chachoos Maramkeri (Farmer's models)'. These different models are basically of either 'stand' type or 'sit and stand' type. Most of the models safety and efficiency aspects are being questioned and needs to be comparatively evaluated and modified. Almost all the available models of coconut climbers were ergonomically tested and results were reported. But no specific testing on the strength and stability were conducted and reported. The safety of the operator is important in climbing up and down the coconut palm. The available coconut palm climbers are made up of different materials and its strength and stability vary one another. There is a need of identifying the load bearing capacity of the climbers to ensure the safety of the climbing person. The strength and stability analysis of different farm machines conducted through Finite Element Analysis (FEA) method were studied as a part of this research work. The strength and stability of selected coconut climber were evaluated under this study. The summary of the results obtained from the analysis and the conclusions drawn out from the study are presented in this chapter.

A detailed prior art search related to the Finite Element Analysis (FEA) were carried out to understand different steps and procedure involved in the analysis. Important research papers and other reference materials related to software modelling and analysis from 2006 to 2017 were collected and

reviewed for studying the strength and stability of the machines under static and fatigue conditions. The collected reviews from various resources were categorized based on the different mechanical coconut palm climbing devices, ergonomic evaluation studies, mechanical analysis and modelling of different farm machineries and testing of farm machines.

Among the different available climbers, two models of 'sit and stand' type coconut climbers viz., 'KAU model' and 'Farmer's model' were selected in this study. The 3D modelling of KAU and Farmer's models of climbers were carried out in Solidworks 13.0 software. The dimensions of various parts of KAU and Farmer's models were recorded by direct measurement. Then the assembly of each component of the top and bottom frames climbers were created in the same software. These 3D models were then saved in step file format. The file was then imported to the ANSYS 15.0 software for the static and fatigue analysis. After importing the geometry into the ANSYS 15.0 software the default meshing was carried out. After meshing the application of boundary condition i.e., loads and fixed supports were applied. In the KAU model, the inner surface of bent tube and V tube was considered as the fixed support as the faces of these inner surfaces are holding firmly the trunk. In the farmer's model, the rope and curve plate was considered as holding part since it will restrict the climber from falling down the palm. In the mechanical analysis of coconut palm climbers, the force is the weight of the person climbing the palm and any other accessories carried with him. The analysis was hence carried out for the forces of 400, 500, 600, 700, 800, 900, and 1000 N separately for top and bottom frames of both the selected models. A minimum weight (force) of 400 N and maximum weight (force) of 1000 N for the operators were considered. It is assumed that major forces acting on the sitting point of the climbers in top frames and on the foot rest point in the bottom frames. The static and fatigue analysis were carried out separately for top and bottom frames of KAU and Farmer's models at loads from 400 N to

1000 N. The resultants of equivalent (Von Mises) stresses, equivalent elastic strain, total deformation, fatigue life and factor of safety are interpreted.

In top frame of KAU model, maximum Von Mises stress of 1.944×10^8 Pa was observed at a load of 1000 N. The maximum Von Mises stress was only 7.7766×10^7 Pa when the load was 400 N. The maximum Von Mises stress was observed in rope tube. The maximum equivalent elastic strain at 400 N and 1000 N were 4.0179×10^{-4} m/m and 1.0044×10^{-3} m/m respectively. The maximum strain occurred on rope tube and minimum on bent tube. The maximum total deformation at 400 N and 1000 N were 2.1075×10^{-3} m and 5.2681×10^{-3} m respectively. The maximum and minimum deformation occurred on straight tube. The minimum fatigue life at 400 N and 1000 N was 1×10^6 cycles and 5.0084×10^5 cycles respectively. The minimum fatigue life occurs in nut. The minimum factor of safety at 400 N and 1000 N was 2.2169 and 0.88684 respectively. The minimum factor of safety occurs in rope tube.

In bottom frame of KAU model, maximum Von Mises stress of 2.0866×10^8 Pa was observed at a load of 1000 N, but the maximum Von Mises stress was only 8.3463×10^7 Pa when the load was 400 N. the maximum Von Mises stress was observed in spring lock washer and minimum in bent tube. The maximum equivalent elastic strain at 400 N and 1000 N were 7.7772×10^{-4} m/m and 1.9443×10^{-3} m/m respectively. The maximum strain occurred on bottom tube and minimum on bent tube. The maximum total deformation at 400 N and 1000 N was 5.9789×10^{-4} m and 1.4947×10^{-3} m respectively. The maximum deformation occurred on bottom tube and minimum on V bent. The minimum fatigue life at 400 N and 1000 N were 1×10^6 cycles and 3.3321×10^5 cycles respectively. The minimum fatigue life occurs in spring lock washer. The minimum factor of safety at 400 N and 1000 N were 2.0656 and 0.82624 respectively. The minimum factor of safety occurs in the spring lock washer.

In top frame of Farmer's model, maximum Von Mises stress of 1.5608×10^8 Pa was observed at a load of 1000 N. but the maximum Von Mises stress was only 6.2431×10^7 Pa when the load was 400 N. The maximum Von Mises stress was observed in lock pin and minimum in rope. The maximum equivalent elastic strain at 400 N and 1000 N were 3.138×10^{-4} m/m and 7.845×10^{-4} m/m respectively. The maximum stain occur on lock pin and minimum on rope. The maximum total deformation at 400 N and 1000 N were 6.8534×10^{-5} m and 1.7133×10^{-4} m respectively. The maximum deformation occur on rectangle plate and minimum on curve plate. The minimum fatigue life at 400 N and 1000 N were 1×10^6 and 1×10^6 cycles respectively. The minimum fatigue life occurs in L plate. The minimum factor of safety at 400 N and 1000 N were 2.7615 and 1.1046 respectively. The minimum factor of safety occurs in the lock pin.

In bottom frame of Farmer's model, maximum Von Mises stress of 1.9208×10^8 Pa was observed at a load of 1000 N. But the maximum Von Mises stress was only 7.6832×10^7 Pa when the load was 400 N. The maximum Von Mises stress was observed in lock pin and minimum in rope. The maximum equivalent elastic strain at 400 N and 1000 N were 3.881×10^{-4} m/m and 9.7025×10^{-4} m/m respectively. The maximum stain occurred on lock pin and minimum on rope. The maximum total deformation at 400 N and 1000 N were 1.2654×10^{-4} m and 3.1635×10^{-4} m respectively. The maximum deformation occur on bottom frame and minimum on curve plate. The minimum fatigue life at 400 N and 1000 N were 1×10^6 cycles and 15.123×10^5 cycles respectively. The minimum fatigue life occurred in L plate. The minimum factor of safety at 400 N and 1000 N were 2.2439 and 0.89755 respectively. The minimum factor of safety occurred in the lock pin.

In order to increase the load bearing capacity it is suggested to change the material, design or dimensions of the parts which will undergo maximum stress.

Test codes are necessary to test any agricultural machines or equipment to issue test reports by any testing agencies. No specific test codes are available to test these climbers, irrespective of the models. The draft test code formulated with the view of improvement of mechanical coconut climber in all aspects. The parameters regarding coconut palm climbers were considered respectively as its field performance, mechanical strength and stability, chemical composition, ergonomic parameters etc. The Minimum Performance Standard (MPS) was also prepared and attached with the draft test code.

CHAPTER VI

REFERENCES

- [Anonymous]. 2018. Coconut development board: All India final estimates of area and production of coconut-2016-17. Available: <http://coconutboard.nic.in/Statistics.aspx> [11 July 2018].
- [Anonymous]. n.da. Lumen boundless physics: Elasticity, Stress, Strain, and Fracture. Available: <https://courses.lumenlearning.com/boundless-physics/chapter/elasticity-stress-strain-and-fracture/> [7 July 2018].
- [Anonymous]. n.db. Quora [on line]. Available: <https://www.quora.com/What-is-the-difference-between-total-deformation-and-directional-deformation-in-context-to-ANSYS-Workbench> [7 July 2018].
- [Anonymous]. n.dc. Wikipedia, the free encyclopedia: factor of safety. Available: https://en.wikipedia.org/wiki/Factor_of_safety [10 July 2018].
- Abdulkarim, K.O., Abdulrahman, K.O., Ahmed, I.I., Abdulkareem, S., Adebisi, J.A., and Harmanto, D. 2017. Finite element analyses of mini combined harvester chassis and hitch. *J. Prod. Eng.* 20(1): 48-54.
- Ahaneku, I. E., Oyelade, O. A., and Faleye, T. n.d. Comparative field evaluation of three models of a tractor. National Centre for Agricultural Mechanization, Ilorin. 90-99.
- Al-Suhaibani, S.A., Al-Janobi, A.A., and Al-Majhadi, Y.N. 2010. Development and evaluation of tractors and tillage

- implements instrumentation system. *Am. J. Eng. Appl. Sci.* 3(2): 363-371.
- Appachan, J. A. 2002. Device to climb arecanut or coconut tree: Second National Grassroots Technological Innovation and Traditional Knowledge Awards. *Natl. Innovation Foundation-India.*
- Armin, A., Szyszkowski, W., and Fotouhi, R. 2016. 3D Finite element analysis of curved blade's mechanics in farming tillage operations. *Proc. World Cong. Eng. 2.*
- Balwani, S.N., and Gulhane, U.D. 2016. Design modification and analysis of shaft of two furrow reversible plough. *Int. J. Sci. Technol. Eng.* 3(3): 108-116.
- Bansal, H., and Kumar, S. 2012. Weight reduction and analysis of trolley axle using ansys. *Int. J. Eng. Manag. Res.* 2(6): 32-36.
- Bansal, R. 2013. Dynamic simulation of a connecting rod made of aluminium alloy using finite element analysis approach. *J. Mech. Civil Eng.* 5(2): 1-5.
- Basavaraja, J. S., Nagaraja, R., and Hegde, S. H. 2015. Design and development of areca tree climber. *Int. J. Res. Mech. Automob. Eng.* 1(2): 83-90.
- Bharti, Y.K., Singh, V., Singh, D., Hussain, A., Lal, S.B., and Tripathi, V.K. 2013. Stress analysis of connecting rod of tractor with weight optimization. *Int. J. Eng. Res. Technol.* 2(4): 1836-1842.
- Bhaskar, E., Muneiah, T., and Rajesh, C.H. 2014. Static and dynamic analysis of chassis. *Int. J. Res.* 1(6): 320-328.

- Bishwal, V.K. and Thomas, J. 2017. Design and stress analysis of cultivator tillage design. *Int. J. Eng. Sci. Res. Technol.* 6(4): 387-390.
- Brian, G.S., David, H.O., Robert, J.W., Jim, E., Alejandro, R., and Jofiel, J.E. 1998. Ergonomic evaluation of hand-hoes for hill side weeding and soil preparation in Honduras. *Ceiba.* 39(2): 183-189.
- Burande, D.H., and Kazi, T.N. 2016. Fatigue analysis of alloy wheel for passenger car under radial load. *Int. J. Eng. Res. Gen. Sci.* 4(2): 26-35.
- Celik, H.K., Rennie, A.E.W., and Akinci, I. 2016. Design and structural optimisation of a tractor mounted telescopic boom crane. *J Braz. Soc. Mech. Sci. Eng.*
- Chen, Y., Fang, J., Shiau, Y., and Hung, W. 2017. A study on static structural of non-rotor unmanned aerial vehicle. *MATEC Web of Conf.*
- Chennuri, V., Kothagadi, H., and Mohammad, R. 2015. Design and stress analysis of four-post rollover protective structure of agricultural-wheeled tractor. *Int. J. Mech. Eng. Rob. Res.* 4(1): 293-305.
- Da silva, E.P., Da silva, F.M., and Magalhaes, R.R. 2014. Application of finite elements method for structural analysis in a coffee Harvester. *Eng.* 6: 138-147.
- Dadhich, M., Jain, S.K., Sharma, V., Sharma, S.K., and Agarwal, D. 2015. Fatigue (FEA) and modal analysis of a centrifugal fan. *Int. J. Recent adv. Mech. Eng.* 4(2): 77-91.

- Dey, S., Murthy, P.R.V.V.V.R.C.D., and Baskar, P. 2014. Structural analysis of front axle beam of a light commercial vehicle. *Int. J. Eng. Trends Technol.* 11: 208-213.
- Edachari, D., Kumar, S., Unakal, P. 2011. Design of a coconut tree climbing device. *Sas Tech.* 10(2).
- Faleye, T., Farounbi, A.J., Ogundipe, O.S., and Adebija, J.A. 2014. Testing and evaluation of farm machines: an essential step for developing mechanization in Nigeria. *Int. Res. J. Agric. Sci. Soil Sci.* 4(2): 47-50.
- Galat, U.N., Ingale, A.N., and Raut, P.M. 2016. Failure investigation of agricultural 9 tyne cultivators used in various soil condition a review. *Int. J. Adv. Res. Innovative Ideas Educ.* 2(2): 275-279.
- Gavali, M., and Kulkarni, S. 2014. Development of rotary weeder blades by finite element method. *Int. J. Sci. Res. Eng. Technol.* 3(6): 941-945.
- Ghumadwar, R.A. and Bankar, V.H. 2016. Design and analysis of crop cutter. *Int. Res. J. Eng. Technol.* 3(7): 1095-1099.
- Hubalovsky, S. 2013. Modeling, Simulation and visualization of static mechanical properties of frame of elevator cab. *Int. J. Math. Models methods in appl. sci.* 6(7): 666-675.
- Hugar, H., Kadewadi, P., Kazi, Z., Kotwal, Z., and Kannur, N. S. 2013. Design and fabrication of coconut tree climbing equipment. Project reference no: 38S0308.
- Jafari, A., Khanali, M., Mobli, H., and Rajabipour, A. 2006. Stress analysis of front axle of JD 955 combine harvester under static loading. *J. Agric. Soc. Sci.* 2(3): 133-135.

- Jahanbakhshi, A., Darreh, S.H.R., and Kheiralipour, K. 2017. Stress analysis of crossbar of moldboard plough pulled by Massey Ferguson 285 and 299 Tractors. *Adv. in Appl. Sci.* 2(1): 11-17.
- Jaikumaran, U., Joseph, S., Preman, P.S., Unnikrishnan, C. Jitha, K.J. and Joseph, C.J. 2016. Design and development of sitting type coconut palm climbing device - "Kera Suraksha Coconut Climber". *J. Trop. Agr.* 54 (1): 136-143.
- Jakasania, R.G., Vadher, A.L., and Yadav, R. 2016. Structural analysis of parabolic type subsoiler using cad software. *Int. J. Sci. Environ. Technol.* 5(5): 3415-3422.
- Jakasania, R.G., Vadher, A.L., and Yadav, R. 2017. Structural analysis of inclined type subsoiler using CAD software. *Internet. J. Agric. Engg.* 10(1): 78-81.
- Jawaharlal, M. 2010. Coconut Tree Climbing Device. www.nciia.org, retrieved on 22nd Oct. 2010.
- Joseph. 2006. Making man reach the moon: Top of Palm .Honey Bee .Vol 17(1) & (2):14.
- Kashid, V.R. and Mane, A.M. 2016. Finite element analysis and optimization of tractor trolley axle. *Int. J. Mech. Eng. Technol.* 7(4): 48-60.
- Kolhe, K.P., Powar, A.G., Dhakane, A.D., and Mankar, S.H. 2014. Stability and ergonomic design features of tractor mounted hydraulic elevator for coconut harvesting. *Am. J. Eng. Appl. Sci.* 4(3): 380-389.
- Kumar, R.D., Dabhi, K.L., and Makwana, A.D. 2017. Comparative performance of tractor drawn implements tillage system with rotavator tillage system. *Int. J. Agric. Sci.* 9(5): 3743-3748.

- Kurowski, P. M. 2012. Von Mises Stress failure criterion [on line]. Available:
http://debis.deu.edu.tr/userweb//zeki.kiral/CAD/Failure_Assessment.pdf [7 July 2018].
- Liao, X., Ma, X., and Zuo, Y. n.d. Design of Rotary Root Stubble Digging Machine Based on Solidworks.
- Makange, N.R., Parmar, R.P., and Tiwari, V.K. 2015. Stress analysis on tyne of cultivator using finite element method. *Trends Biosci.* 8(15): 3919-3923.
- Malon, H., Aguirre, A.J., Bone, A., Vidal, M., and Garcia-Ramos, F.J. 2015. Design and testing of an agricultural implement for underground application of rodenticide bait. *Sensors.* 15:
- Manasa, P. and Reddy, C.V.B. 2013. Static analysis of tractor trolley axle. *Int. J. Eng. Trends Technol.* 4(9): 4183-4187.
- Manivelprabhu, C., Sangeetha, N., and Ramganes, T. 2015. Design modification and structural analysis of rotavator blade by using hyper works 12.0. *Altair. Technol. Conf.*
- Mathew, A. C. and Krishnan, M. V. 2015. Coconut and arecanut palm climbing device. Indian patent-268548.
- Mirehei, A., Zadeh, M.H., Jafari, A., and Omid, M. 2008. Fatigue analysis of connecting rod of universal tractor through finite element method (ANSYS). *J. Agric. Technol.* 4(2): 21-27.
- Mollazade, K., Jafari, A., Ebrahimi, E. 2010. Application of dynamical analysis to choose best subsoiler's shape using ANSYS. *N.Y. Sci. J.* 3(3): 93-100.
- Naeini, H.S., Karuppiah, K., Tamrin, S.B. and Dalal, K. 2014. Ergonomics in agriculture: An Approach in prevention of

- work-related Musculoskeletal Disorders (WMSDs). *J. of Agric. Env. Sci.* 3(2): 33-51.
- Rahul, V., Babu, S., Moideen, S.C.P., Vineeth, V.P., and Ninan, N. 2015. Semi automated coconut tree climber. *Int. J. Res. Eng. Technol.* 4(3): 532-539.
- Rajashekar, M., Heblikar, V.K., and Kumar, S.M. 2014. Simulation and analysis of low cost weeder. *Int. J. Res. Eng. Technol.* 3(3): 543-549.
- Ren, Y., Yu, Y., Zhao, B., Fan, C., and Li, H. 2016. Finite element analysis and optimal design for the frame of SX360 dump trucks. *Procedia Eng.* 174: 638- 647.
- Sachin, R. and Rakesh, C. 2016. A study on fatigue life optimization and performance analysis of wheel disc. *Int. J. Eng. Dev. Res.* 4(4): 23-29.
- Sadiq, R.J., Krishna, S.G.G., and Udupa, N.G.S. 2015. Structural analysis and performance evaluation of multi-purpose agricultural equipment. *Int. J. Adv. Prod. Mech. Eng.* 1(1): 49-55.
- Syedabadi, E. 2015. Finite Element Analysis of Lift Arm of a MF-285 Tractor Three-Point Hitch. *J. Fail. Anal. and Prev.* 15:737–743.
- Shaari, M.S., Rahman, M.M., Noor, M.M., Kadirgama, K., and Amiruddin, A.K. 2010. Design of connecting rod of internal combustion engine: A topology optimization approach. National Conference in Mechanical Engineering Research and Postgraduate Studies. 155-166.

- Shafi, M., Reddy, P., Purushotham, A., and Rao, B.M. 2016. Dynamic and fatigue analysis on tillage equipment. *J. Mech. Civil Eng.* 13(6): 158-167.
- Shahu, M. 2017. Design of Inclined Metering Mechanism Based on Solid-works. *Int. J. Eng. Res. Technol.* 6(12): 70-73.
- Sharma, P. and Bhargava, M. 2015. Parametric design analysis and FEA simulation of a chisel plow for an agriculture use. *Int. J. Recent adv. Mech. Eng.* 4(4): 45-58.
- Shinde, G.U and Kajale, S.R. 2011. Computer aided engineering analysis and design optimization of rotary tillage tool components. *Int. J. Agric. Biol. Eng.* 4(3): 1-6.
- Shiru, J.J. and Shehu, A. 2012. Anthropometry in engineering design (a case study of cassava grating machines installed in doko and kutigi metropolis of lavun local government areas of niger state). *The Nigerian Academic Forum* Volume 22(1).
- Singh, R. 2006. Introduction to basic manufacturing process and workshop technology, New Age International (P) Ltd. Publishers, New Delhi, 493p.
- Ssomada, M.A.H.A., Hudzaria, R.M., Noordinb, M.N.A., Sapuanc, S.M., Norhayatia, N., and Soranb, A.J. 2013. Finite element analysis for stress distribution of hand tool harvester. *Procedia Eng.* 68: 219-224.
- Tarighi, J., Mohtasebi, S.S., and Alimardani, R. 2011. Static and dynamic analysis of front axle housing of tractor using finite element methods. *Australian J. Agric. Eng.* 2(2): 45-49.
- Thyagarajan, R., Kathirvel, K.K. and Jayashree, G. C. 2012. Ergonomical evaluation of two row finger type rotary weeders for paddy. *J. of Agric. Eng. Tech.* 20(1).

- Topakci, M., Celik, H.K., Yilmaz, D., and Akinci, I. 2008. Stress analysis on transmission gears of a rotary tiller using finite element method. *Akdeniz Üniversitesi Ziraat Fakültesi Dergisi*. 21(2): 155–160.
- Tripathi, P.S., and Crasta, P.F. 2017. A review on fatigue behaviour of connecting rod made of Austempered Ductile Iron. *Int. Res. J. Eng. Technol.* 4(5): 2691-2696.
- Yegul, U., Eminoglu, M.B., Obel, O., and Colak, A. Determination of equivalent stress and total deformation in different types of harrows. *J. Agric. Machinery Sci.* 10(1): 65-71.
- Yilmaz, D., Hamamci, E., Salik, D., and Ahiskali, Y. 2011. Structural analysis of agricultural machinery: A case study for a transport chassis of a spraying machine. *J. Agric. Machinery Sci.* 7(4): 405-409.

**COMPUTER AIDED ANALYSIS OF 'SIT AND STAND' TYPE
COCONUT CLIMBERS FOR MECHANICAL STABILITY**

By

POOJA V

(2016-18-001)

ABSTRACT OF THESIS

Submitted in partial fulfilment of the requirement for the degree

Master of Technology

In

Agricultural Engineering

(Farm Power Machinery and Energy)

Faculty of Agricultural Engineering and Technology

Kerala Agricultural University



DEPARTMENT OF FARM MACHINERY AND POWER ENGINEERING

KELAPPAJI COLLEGE OF AGRICULTURAL ENGINEERING AND

TECHNOLOGY, TAVANUR – 679 573

KERALA, INDIA

2018

ABSTRACT

Coconuts are harvested by climbing the palm and cutting the nuts down by hand. Manually climbing up and down the palm is hazardous and tedious. Now a days a few models of mechanical coconut palm climbers are available to overcome these drawbacks. Testing the mechanical strength and stability of the coconut palm climbers is necessary to ensure its safe performance under working condition. Among these types, KAU and Farmer's models were selected and its three dimensional models were generated in Solidworks 13.0 software. The static and fatigue analysis of these selected models were carried out in the ANSYS 15.0 software. The assembly of each component of the top and bottom frames of the models were created and saved in step file format. The file was then imported to the ANSYS 15.0 software for the static and fatigue analysis. Preprocessing steps such as meshing, selection of material and application of boundary conditions were then carried out sequentially to establish static and fatigue problems. In the KAU model top and bottom frames were steel and aluminium materials, wherein the Farmer's model top and bottom frame were made of structural steel. The boundary conditions imposed are the application of loads and fixing of supports. Various loads of 400, 500, 600, 700, 800, 900 and 1000 N were applied and under each load the analysis was carried out. In the KAU model, the inner face of the bent tube and V tube and in the Farmer's model, the rope and curve plate were considered as fixed supports. The static analysis interpreted were the equivalent (Von-Mises) stress, equivalent elastic strain and total deformation while fatigue analysis interpreted the fatigue life and factor of safety.

The results showed that as the load increased the Von Mises stress was found increased. Also, there were decreasing trends for the factor of safety and fatigue life. The top frame of KAU models have factor of safety more than three, two and one up to 400, 500 and 1000 N load respectively. The infinite fatigue life cycles were observed up to 800 N. The bottom frame of KAU model have factor of safety more than one up to a load of 1000 N and have infinite fatigue life cycles up to 1000 N load. Hence KAU model is safe to operate up to a load of 1000 N. The top and

bottom frames of the Farmer's model also found out the factor of safety more than one and have infinite fatigue life cycles up to load of 1000 N. Hence Farmer's model is safe to use up to a load of 1000 N. further changes in material, design or dimensions are suggested to get more factor of safety for loads from 700 to 1000 N for both the selected models. As there is no specified test codes available for manually operated mechanical tree climbers, a draft test code with Minimum Performance Standard (MPS) was also prepared under this study.