

**DEVELOPMENT AND PERFORMANCE EVALUATION OF A TRACTOR  
POWERED MANURE PULVERIZER CUM APPLICATOR**

**By**

**S. SAI MOHAN**

**(2018-18-016)**



**DEPARTMENT OF FARM MACHINERY AND POWER ENGINEERING**

**KELAPPAJI COLLEGE OF AGRICULTURAL ENGINEERING AND  
TECHNOLOGY**

**TAVANUR – 679 573**

**KERALA, INDIA**

**2020**

**DEVELOPMENT AND PERFORMANCE EVALUATION OF A TRACTOR  
POWERED MANURE PULVERIZER CUM APPLICATOR**

**By**

**S. SAI MOHAN**

**(2018-18-016)**

**THESIS**

**Submitted in partial fulfilment of the requirement for the degree of**

**MASTER OF TECHNOLOGY**

**IN**

**AGRICULTURAL ENGINEERING**

**(Farm Power and Machinery)**

**Faculty of Agricultural Engineering and Technology**

**Kerala Agricultural University**



**DEPARTMENT OF FARM MACHINERY AND POWER ENGINEERING**

**KELAPPAJI COLLEGE OF AGRICULTURAL ENGINEERING AND  
TECHNOLOGY**

**TAVANUR – 679 573**

**KERALA, INDIA**

**2020**

## **DECLARATION**

I hereby declare that this thesis entitled “**Development and Performance Evaluation of a Tractor Powered Manure Pulverizer cum Applicator**” is a bonafide record of research work done by me during the course of research and the thesis has not previously formed the basis for the award to me of any degree, diploma, associateship, fellowship or other similar title of any other University or Society.

Place: Tavanur

Date: 01-10-2020

**S. SAI MOHAN**

**(2018-18-016)**

## **CERTIFICATE**

Certified that this thesis entitled “**Development and Performance Evaluation of a Tractor Powered Manure Pulverizer cum Applicator**” is a bonafide record of research work done independently by Mr. S.SAI MOHAN (2018-18-016) under my guidance and supervision and that it has not previously formed the basis for the award of any degree, diploma, fellowship or associate ship to him.

Place: Tavanur

Date: 01-10-2020

**Dr. Jayan P R**

(Major Advisor, Advisory Committee)

Professor and Head

Department of FMPE

KCAET, Tavanur.

## **CERTIFICATE**

We, the undersigned members of the Advisory Committee of **Mr. S. SAI MOHAN** (2018-18-016) a candidate for the degree of Master of Technology in Agricultural Engineering with majoring in Farm Power, Machinery and Energy, agree that the thesis entitled “**Development and Performance Evaluation of a Tractor Powered Manure Pulverizer cum Applicator**” may be submitted by Mr. S. SAI MOHAN in partial fulfilment of the requirement for the degree.

**Dr. Jayan P R**  
(Chairman, Advisory Committee)  
Professor & Head  
Dept of FMPE  
KCAET, Tavanur  
(Member)

### **Members:**

**Dr. Shaji James P.**  
(Member)  
Professor  
ARS, Mannuthy

**Er. Sindhu Bhaskar**  
(Member)  
Asst professor  
Dept. of FMPE  
KCAET, Tavanur

**Dr. Jyothi M.L.**  
(Member)  
Prof. & ADR (Farms)  
KAU, Vellanikkara

**Dr. A. Carolin Rathinakumari**  
(External Examiner)  
Principal Scientist (FMP)  
ICAR-IIHR  
Bengaluru

## **ACKNOWLEDGEMENT**

*This is a pleasure to glance back and recall the path one travels during the days of hard and stress. It is still great at this moment to recall all the faces and spirits in the form of teachers, friends, near and dear ones. I take this opportunity to express my deep sense of gratitude to supreme God for his pity and blessings to accomplish of my work and for all the things which I made today.*

*At this moment of accomplishment, I would like to express heartfelt gratitude to my major advisor **Dr. Jayan P R**, Professor and Head, Dept of Farm Machinery and Power Engineering, KCAET, Tavanur, Kerala. I consider myself lucky to have worked under the guidance of the knowledge hungry, excellence pursuing and ever helpful personality. I am very thankful for his untiring commitment, for his efficient guidance, constant encouragement and above all the love and affection offered to me during the course of my research work. I just find it difficult to forget the ease with which he could include the confidence and optimism in me through the media of his looks, without which this would have far from reality.*

*I sincerely thank **Dr. K.K. Sathian**, Dean (Agrl. Engg), Kelappaji college of Agricultural Engineering and Technology, Tavanur for providing essential support and permission to use various facilities for the field and analysis work.*

*I engrave my deep sense of gratitude to **Dr. Shaji James**, Professor, ARS, Mannuthy, **Dr. Jyothi M.L.**, Prof.&ADR (Farms), KAU, Vellanikkara and **Er. Sindhu Bhasker**, Assistant Professor, Department of FMPE, KCAET, Tavanur members of the advisory committee for their constant backing of constructive suggestions and kind support.*

*I am immensely thankful to **Er. Shivaji, K. P.**, Assistant Professor, RARS, Ambalavayal and **Er. Sanju Sukumaran**, Assistant Professor, Department of FMPE, KCAET, Tavanur for giving valuable suggestions and constant backing at all stages of this research work.*

*I also take this opportunity to express heartfelt thanks to all the Technicians mainly **Lithin, Kannan, Dhanesh, Prasoon, Manu, Sudheer and Lenin** of KCAET,*

*Tavanur, and **Er. Younus Athikkot**, Asst. Prof. (contract), Dept. of FMPE, KCAET, Tavanur for their help during the period of study and their technical help in fabrication and testing of the unit. The work would not have been completed successfully without their technical support.*

*I sincerely thank my M.Tech friends, seniors and juniors especially **Vamshi, Mohan, Babu, Rathanavel, Athira, Meera, Megha, Geethu and Suraja** who were always forthright in lending a helping hand during my research work and thesis completion.*

*I am very thankful to my seniors **Er. Basavaraj Patil, Er. srinivas J, Er. Venkat Reddy, Er. G Gopi, Er. M.M.Pasha, Er. Venkat sai and Er. N Kalyan** for their suggestions and invaluable help during my study.*

*My heartfelt thanks to Kerala Agricultural University in providing the favourable circumstances for the study. One last word; since it is practically impossible to list all the names who have contributed to my work, it seems proper to issue a blanket of thanks for those who helped me directly or indirectly during the course of study.*

**S. SAI MOHAN**

## CONTENTS

Chapter No	Title	Page No.
	LIST OF TABLES	i
	LIST OF FIGURES	ii
	LIST OF PLATES	vi
	ABBREVIATIONS AND SYMBOLS	vii
I	INTRODUCTION	1
II	REVIEW OF LITERATURE	4
III	MATERIALS AND METHODS	21
IV	RESULTS AND DISCUSSIONS	75
V	SUMMARY AND CONCLUSION	112
VI	SUGGESTIONS FOR FUTURE WORK	116
VII	REFERENCES	117
VIII	APPENDICES	122
	ABSTRACT	



**LIST OF TABLES**

<b>Table No.</b>	<b>Title</b>	<b>Page No.</b>
3.1	Nutritional composition of manure	21
3.2	Spacing of various vegetables	28
3.3	Description of levels of variables	36
3.4	Elevation view of developed p.t.o shaft	58
3.5	Velocity ratio of selected pulleys	64
3.6	Lengths of various belts	65
3.7	Effect of drift on pulverizer	69
4.1	Coefficient of friction of pulverized manure	78
4.2	Specification of KAU manure pulverizer	93
4.3	Specification of prototype manure pulverizer cum applicator	94
4.4	Variation in gearbox output speeds	97
4.5	Application rates of selected types of manures	110

## LIST OF FIGURES

Fig. No.	Title	Page No.
3.1	Rotating blade	30
3.2	Elevation view of KAU manure pulverizer	31
3.3	KAU manure pulverizer	31
3.4	Elevation view of supporting frame	37
3.5	Elevation view of supporting stand	38
3.6	Supporting frame and 3-point hitch system	39
3.7	Blower working principle	40
3.8	Inlet and outlet velocity triangles for various impeller	40
3.9	Elevation view of Paddle type impeller	43
3.10	Elevation view of Straight 6-blade impeller	44
3.11	Elevation view of Straight 4-blade impeller	44
3.12	Elevation view of Radial impeller	45
3.13	Supporting stand for blower	46
3.14	Circuit connection diagram of VFD and motor	47
3.15	Elevation view of blower casing and hopper	48
3.16	Experimental setup of blower working model	48
3.17	Blower working model	48
3.18	Various parts of the gearbox experimental setup	52
3.19	Line diagram of a 3-way right angle bevel gearbox model	52
3.20	Arrangement of spur gears	53
3.21	Elevation view of drilled holes	56
3.22	Elevation view of P.T.O. coupling	57
3.23	Elevation view of input P.T.O shaft	57
3.24	Elevation view of shafts	59
3.25	Arrangement of gears	60
3.26	Gearbox prototype	61
3.27	Variation in gearbox output speeds	62

3.28	Line diagram of extension shaft	62
3.29	Arrangement of two double v-belt pulleys	63
3.30	Selected sizes of block bearings and pulleys	63
3.31	Chute	66
3.32	Elevation view of blower casing and inlet	67
3.33	Outlets with discharge controllers	68
3.34	Elevation view of closed radial blade impeller	69
3.35	Manure pulverizer cum applicator	70
3.36	Front and side view of developed unit	71
3.37	Elevation view of the developed unit	71
3.38	Layout of experimental field	73
4.1	Avg. bulk densities of manures <i>viz.</i> , cow dung, goat faecal pellets and neem cake	76
4.2	Avg. tapped densities of manures <i>viz.</i> , cow dung, goat faecal pellets and neem cake	76
4.3	Variation in suction velocity with impeller RPM	80
4.4	Air velocity along the circumference of paddle type impeller (40 Hz)	81
4.5	Variation of air velocity in case of paddle type impeller	82
4.6	Air velocity along the circumference of straight 6- blade impeller (40 Hz)	83
4.7	Variation of air velocity in case of straight 6-blade impeller	83
4.8	Air velocity along the circumference of straight 4- blade impeller (40 Hz)	84
4.9	Variation of air velocity in case of straight 4-blade impeller	84
4.10	Air velocity along the circumference of radial impeller (40 Hz)	85
4.11	Variation of air velocity in case of radial impeller	85

4.12	Variation of discharge w.r.to frequency in case of paddle type impeller	87
4.13	Variation of discharge w.r.to frequency in case of straight 6-blade impeller	88
4.14	Variation of discharge w.r.to frequency in case of straight 4-blade impeller	88
4.15	Variation of discharge w.r.to frequency in case of radial impeller	89
4.16	Coefficient of variation of discharge at outlets w.r.to frequency	90
4.17	Discharge rate of manure w.r.to impeller rpm	91
4.18	Variation in suction velocity with impeller rpm	97
4.19	Variation in air velocity with blower rpm	98
4.20	Variation in discharge with blower rpm using cow dung (valve at full open condition)	99
4.21	Variation in discharge with blower rpm using goat faecal pellets (valve at full open condition)	100
4.22	Variation in discharge with blower rpm using neem cake (valve at full open condition)	100
4.23	Variation in discharge with blower rpm using cow dung (valve at half open condition)	101
4.24	Variation in discharge with blower rpm using goat faecal pellets (valve at half open condition)	102
4.25	Variation in discharge with blower rpm using neem cake (valve at half open condition)	103
4.26	Variation in discharge rate with blower rpm (valve at full open condition)	104
4.27	Variation in discharge rate with blower rpm (valve at half open condition)	105
4.28	Variation in CU with blower rpm (valve at full open condition)	106

4.29	Variation in CU with blower rpm (valve at half open condition)	107
4.30	Effect of engine rpm and travelling speed on application rate of manure (Valve at full open condition)	108
4.31	Effect of engine rpm and travelling speed on application rate of manure (Valve at half open condition)	109
4.32	Cost economics of convention practices Vs manure applicator	111

---

## LIST OF PLATES

Plate No.	Title	Page No.
3.1	Determination of moisture content by hot air oven	34
3.2	Sieve analysis by mechanical sieve shaker	34
3.3	Anemometer and tachometer	34
3.4	Category II hitching system	38
3.5	Lowest reach position of tractor lower links	38
3.6	Paddle type impeller	43
3.7	Straight 6-blade impeller	44
3.8	Straight 4-blade impeller	44
3.9	Radial impeller	45
3.10	Blower casing	49
3.11	Difficulty in manure input	49
3.12	Hopper provided at eye	50
3.13	Experimental setup of 3-way right angle gearbox	53
3.14	Mild steel plate of 12mm thickness	54
3.15	Spur gears and bevel gears	55
3.16	P.T.O shaft and output shafts	59
3.17	Assembly of gearbox	61
3.18	Tractor powered manure pulverizer cum applicator prototype	72
3.19	Levelling of experimental field	74
3.20	Rows formation	74
3.21	Field evaluation of developed unit	74

**ABBREVIATIONS AND SYMBOLS**

%	:	Per cent
&	:	And
@	:	At the rate of
+	:	Plus
±	:	Plus or minus
°	:	Degree
°C	:	Degree centigrade
ANOVA	:	Analysis of variance
cm	:	Centimeter
cm <sup>2</sup>	:	Square centimeter
cm <sup>3</sup>	:	Cubic centimeter
CV	:	Coefficient of variation
db	:	dry basis
<i>et al.</i>	:	and others
etc.	:	et cetera
Fig.	:	Figure
g	:	Gram
g cm <sup>-3</sup>	:	Gram per cubic centimeter
ha	:	Hectare
ha h <sup>-1</sup>	:	Hectare per hour
hp	:	Horse power
hr	:	Hour
hr ha <sup>-1</sup>	:	Hour per hectare
IS	:	Indian standards
KAU	:	Kerala Agricultural University
KCAET	:	Kelappaji college of agricultural engineering and technology

kg	:	Kilogram
kg cm <sup>-2</sup>	:	Kilogram per square centimeter
kg ha <sup>-1</sup>	:	Kilogram per hectare
kg m <sup>-3</sup>	:	Kilogram per cubic meter
kg mm <sup>2</sup>	:	Kilogram per square millimeter
kgf	:	Kilogram force
km h <sup>-1</sup>	:	Kilometer per hour
l hr <sup>-1</sup>	:	Liter per hour
m	:	Meter
m s <sup>-1</sup>	:	meters per second
m <sup>2</sup>	:	Square meter
m <sup>3</sup>	:	Cubic meter
mm	:	Millimeter
MS	:	Mild steel
N	:	Newton
rpm	:	Revolutions per minute
Rs	:	Rupees
Rs ha <sup>-1</sup>	:	Rupees per hectare
Rs h <sup>-1</sup>	:	Rupees per hour
SD	:	Standard deviation
Sl. No.	:	Serial Number
SS	:	Stainless steel
t	:	Tons
<i>viz.</i>	:	Namely
wb	:	Wet basis



# INTRODUCTION

## **CHAPTER I**

### **INTRODUCTION**

Agricultural production needs to be stepped up to meet the increasing demand of the expanding population of India. This can be attained through higher crop productivity on a sustained basis, since expansion of cultivable area has a little scope. Yield improvement could be achieved through the use of high yield varieties and fertilizers.

However, it has been realized that the continued application of chemical fertilizers deteriorates soil qualities and on the other hand, application of organic manures help in building up fertility levels and improves soil quality. Organic manures such as farm yard manure, green manure etc., when incorporated into the soil not only add nutrients but enriches the soil by the fixation of atmospheric nitrogen. The experiments with FYM have shown that the physical properties of soil are improved when compared to the soil treated with chemical fertilizers.

Manures (FYM, vermicompost, edible oil cakes etc.,) are important resources which provide nutrients that could reduce bagged fertilizer costs and improves the crop growth and performance. A well-managed manure is a valuable resource in providing nutrients for crop production. Use of farm yard manure and other organic manure is the way out to overcome the problems of soil degradation, loss of fertility and soil health. A larger portion of nitrogen is made available, as and when the FYM decomposes. Application of FYM improves soil fertility, therefore there is wide scope for its application. Also, the application of recommended doses of manures at the proper time would stabilize the soil fertility status and hence improves soil productivity.

Solid manure is spread using traditional method followed by tillage to incorporate the manure into the soil or by using a broadcasting equipment. Delay in incorporation results in risk of nutrient loss in runoff, volatilization losses of manure nitrogen and increased odour. The problem faced during manure spreading is not only in its application rate but also its uniformity of spread.

Problems like drift and drudgery caused due to manual manure spreading results in health problems. Improper and inaccurate broadcasting causes abnormal and non-homogeneous soil fertility which is against to the purpose of sustainable agriculture.

Hence, there is always a need for using innovative manure applicator machines in the farm.

As manure dries, nutrients not only get concentrated on a weight basis, but also on a volume basis due to structural changes. Compared to fresh manure, it is easier to handle and transport because of decreased volume and weight. Additionally dehydrated manure has a consistent texture and is easier to apply to gardens. Dehydrated manure has a lower pathogen and weed seed content than fresh manure. When manure is dried up to 10-17 % of moisture content and ground into a fine soil like texture, nutrients are more concentrated and the soluble salt level is probably higher in dehydrated manure than in locally available farm manure.

Due to the availability of large farming area, heavy equipments like solid and liquid manure applicators are commonly used in many countries. The application of manure has become mechanized in other countries but in India the indigenous methods are still followed, i.e. loaded trolley or bullock cart is moved in the field and stopped at regular interval where a man other than the driver unloads a small amount of manure and drops it in the form of a heap. These heaps are later spread around manually with spades, which is laborious, tedious, uneconomical and time consuming process. The existing practice of leaving manure in small heaps scattered in the fields prior to the field application for a very long period lead to loss of nutrients. These losses can be reduced by spreading the manure and incorporating by ploughing immediately after application (Reddy and Reddy, 2017). The problem faced in the application of manure during the indigenous method is the non-uniform application rate and non-disintegration of large manure clumps.

Manure gets decomposed as soon as it put on the soil by the action of microorganisms present in the soil. To speed up the decomposition process, it is necessary to break up the manure clods and make more surface area exposed to the microorganisms. Lesser the manure clod size better the surface area exposed for the attack of microorganisms. Also scientific studies revealed that the fine powder is easily absorbed by the soil, easy to handle due to decreased volume and more nutrient concentration in less weight.

Hence, it is necessary to pulverize the manure when it is applied to the land. Considering the Indian farm holding capacities a small scale tractor powered machinery that can both pulverize the manure and apply in the field is recommended. In an attempt, for solution to problems with indigenous method of manure application and to pulverize the large undecomposed manure clods, an implement was developed and tested to pulverize and spread the organic manure simultaneously in the field, which is compatible to the tractor p.t.o drive.

Kerala Agricultural University, Tavanur developed a manure pulverizer that uses drive from a single phase, 2.0 hp electric motor that helps in pulverizing the manure. Due to the non-availability of electric power in remote areas and fields, use of tractor power is a viable solution. For operating in such situations, use of tractor p.t.o for operating a pulverizer along with applicator is an added advantage. Hence it is envisaged to utilize the tractor p.t.o power for operating KAU manure pulverizer for basal application of manures in soil directly.

In view of these, a research work is undertaken with the following objectives:

1. To integrate the KAU manure pulverizer with tractor power take-off
2. To develop a manure applicator for the pulverizer
3. To study the performance of the developed manure pulverizer cum applicator

# REVIEW OF LITERATURE

## **CHAPTER II**

### **REVIEW OF LITERATURE**

Previous research works carried out on manure requirements of different soils, physical properties of manure, machine and performance parameters affecting pulverizer cum applicator are discussed in this chapter.

- Properties of manure
- Working pulverization models
- Studies on manure application
- Studies on powder flowability and effects
- Studies on blower mechanism
- Cost economics of manure spreader

#### **2.1 PROPERTIES OF MANURE**

Reiman *et al.* (2009) studied the impacts of placing the manure at depths on crop yields and N retained in soil. Water infiltration, changes in soil N and P for up to 30 months, crop yield monitoring for three seasons were carried out at deep manure injection (45 cm), shallow manure injection (15 cm), and conventional fertilizer application per site. The fertilizer application rates for the conventional method were 168 kg N ha<sup>-1</sup>, 20 kg P ha<sup>-1</sup>, and 46 kg K ha<sup>-1</sup> respectively and were applied prior to tillage and planting each year. Results indicated that the deep injection had 31, 59 and 44 more kg N ha<sup>-1</sup> than the shallow injection treatments at 12, 18 and 30 months after application. Deep injection system increased the corn yield because of the increased nitrogen use efficiency however there was no impact in soybean yield. Also suggested that in case of a glacial till soil the deep manure placement was considered to increase nitrogen use efficiency and maintain ground water quality.

Julienne *et al.* (2010) studied the effect of manure type, application rate, and application method on odours from manure spreading. Basal application of manure was an effective means of recycling the nutrients to increase the soil nutrient content. Also odours from manure application activities causes potential nuisance to neighbours and creates difficulties for the expansion of the livestock industry. The study aimed at

assessing the efficiency of subsurface application with reducing odours from both solid and liquid manure applications. Flux chambers and dynamic dilution olfactometry were used to detect odours. The results indicated that odour concentrations from subsurface application plots were lower than the concentrations of surface application plots. Due to better manure coverage in subsurface application it was seemed to have a larger impact on reducing odours from solid manure than liquid manure. From the results, it was concluded that subsurface application of solid manure was an efficient way to reduce the overall odour emissions.

Elizabeth *et al.* (2012) conducted studies on the effect of manure on soil organisms and soil quality. The short and long-term effects of manure amendments, processes affecting yield at initial and final application were studied. The addition of manure to soil results in increased yields of nutrient deficient cropping systems, by addition of nutrients. Long-term increase in yield may be due to delayed nutrient release or increase in soil quality. Manure application showed profound effects on soil structure, chemistry and organisms and have also been found to suppress soil pathogens and diseases. Potential negative effects of manure additions such as nutrient loss and enhanced greenhouse gas emissions from soils were minimized through regulating application rate and timing. Strategic management of animal manures could be a cost-effective way to increase soil organic matter content and improved physical structure but ultimately improved the crop yields.

Jotautiene *et al.* (2017) carried out investigations on geometrical and aerodynamic parameters of granular manure fertilizers. Granular organic manures of two different sizes were used in the study. Various parameters like aerodynamic resistance coefficient, particle velocity and coefficient of flow rate were determined. To predict the trajectory of individual granular manure particles from the disc, a theoretical model was developed. The study concluded that coefficient of flow rate was dependent on the pellet diameter. Also by increasing diameter of the pellet the coefficient of flow rate was decreased, whereas decreasing the pellet diameter increased the flow rate. A finite element model (FEM) was developed to study the properties that determine the characteristics of spreading. The coefficient of flow rate of granular material was found

to be 0.37 s and 0.32 s at an average critical pellet velocities of  $16.3 \text{ m s}^{-1}$  and  $17.4 \text{ m s}^{-1}$  respectively.

## 2.2 WORKING PULVERIZATION MODELS

Etamaihe and Iwe (2014) developed and evaluated the performance of a reciprocating motion cassava shredder. The machine consisted of a hopper, shredding plate, slider crank mechanism and a motor. Slider crank mechanism provided motion to the horizontal shaft through an electric motor with a belt under primary speed reduction. Peeled cassava roots were filled in the hopper that was directly above the shredding plate coupled to a reciprocating shaft. Shredding plate derives its motion from the reciprocating shaft and shredded the roots into thin samples. The capacity of the machine was found out as  $320 \text{ kg h}^{-1}$ . The results revealed that the size of the shredder effected the shredding efficiency of the machine. The shredding efficiency of the machine was found decreasing with increasing shredding aperture but increased with shredding speed. Maximum shredding efficiency of 92 % was obtained with a shred aperture of 3 mm and shredding speed of 975 rpm. The throughput capacity of the machine was found to be  $319.89 \text{ kg h}^{-1}$  at 975 rpm and  $301.54 \text{ kg h}^{-1}$  at 325 rpm respectively.

Jayan *et al.* (2017) developed and tested KAU manure pulverizer. It consisted of a pulverizing drum, blades, sieve, feeding hopper and supporting frame. The objective of the study was to powder the dried manures like cow dung, goat faecal pellets and neem cake. Dried manures were fed into the pulverizing drum from the hopper through the feeding chute and get pulverized due to the rotation of pulverizing blade. An electric motor(AC) was used as a prime mover for working. The developed manure pulverizer was tested to optimize the manure and machine parameters. The results indicated that the manures with different moisture contents were pulverized at variable clearances between the sieve and blade. The performance of the machine was optimum at 15 mm clearance when 5 mm sieve was used.

Jitendra *et al.* (2018) evaluated the performance of grinding machine developed for commercial manufacturing of quality vermicompost. The machine consisted of a motor, gear box, adjustable blade, bearing, drum and an adjustment blade shaft. The



machine carried out grinding of all types of dry and moist items. The electric motor operated the batch type media mixer having blade type agitators provided on a shaft rotating at 210 rpm for thorough mixing. The mixer had a capacity range varying from 250 to 300 kg per batch and takes 6 minutes for thorough mixing of vermicompost. The grinding machine was found to be best for 30 kg dry leaf wastes on operation for six minutes. Vermicompost manufactured from the raw material noted lowest nitrogen content (0.8 %) for cow dung and that prepared from mixture of black tea + cow dung noted highest nitrogen content (3.14 %). The pH value of manufactured vermicompost was found out as 5.1 for black tea and 7.1 for poultry manure. When the temperature and moisture content were maintained at 30-35 °C and 30-45 % (dry weight basis), a good quality vermicompost was obtained.

### 2.3 STUDIES ON MANURE APPLICATION

Glancey (1996) developed an applicator for side dressing row crops with solid waste. The objective of the applicator was to use the poultry waste as manure for meeting nutrient demand in crops. A laboratory test was conducted using a single screw conveyor for metering the solid manure and delivering it in between the rows. The laboratory operation showed that the conveyor was inconsistent due to plugging and clogging of powdered manure. Hence an alternative approach by providing separate conveyors for every row was chosen. The selected spreader was modified by increasing the box capacity, ground clearance and a hydraulic system to power the side dresser. The side dresser was attached to New Holland beater type manure spreader. A manure application rate of developed applicator was obtained as 1810 to 11000 kg ha<sup>-1</sup> with a nitrogen application rate of 27 to 170 kg N ha<sup>-1</sup> respectively.

Richard *et al.* (1999) studied about solid manure application towards a sophisticated spreader. It aimed at effective replacing of commercial fertilizer with manure, and also assuring crop producers for delivering a fairly uniform and controlled rate of application. He also added that obtaining accuracy in spreading can help the farmers in achieving full credit for manure nutrients which will be critical in the coming years. Study concluded the need to train spreader operators through calibration and compensating the effect of wind. Since operator skill cannot transform the nature of equipment which was already built, so there was a need for new mechanical manure

application systems. Also current solid manure application equipment's does not address uniformity requirements and application rate control. The study finally concluded the need to take sophisticated approach for manure application.

Mari G.R. (2000) carried out the performance evaluation of a tractor operated manure spreader. The objective of the study was to assess the performance of the spreader so that farmers can be advised to adopt the machine for better results. Spreader was powered by FORD-6610 diesel operated engine and maintained at low gear. Moisture content of manure was maintained at 19.2 % throughout the experiment. The results showed that a travel reduction of 3.2 % was recorded due to time lost in turning, fuel fillings and adjustments. A field capacity of 1.26 ha h<sup>-1</sup> was obtained with a fuel consumption of 20.13 l h<sup>-1</sup>. Also a higher field capacity was observed when the tractor was operated at high speed with decrease in fuel consumption. Cost economics revealed that manure spreading with spreader costs Rs.322 for one hectare whereas manual spreading costed Rs.640. Hence 50 % saving in cost was expected by mechanical spreading irrespective of time saving and uniformity in spreading.

Lague *et al.* (2006) designed and developed a precision applicator for solid and semi-solid manure application. Study on various physical and flow properties of solid and semi-solid manures was also conducted. The lab and field experiments are focused on the manure and transverse distribution system of two prototype machines. Hence the performances of two discharge systems was investigated. The results indicated that a four-auger system was more effective than a scraper conveyor. It helped in effective handling of a variety of manure products. A 305 mm auger conveyor was used for providing six equally spaced openings for transverse distribution. Individual application rates for solid and semi-solid manures ranged between 15 and 18 % of the total application rate. The average specific energy requirements ranged from 325 to 520 W kg<sup>-1</sup> s<sup>-1</sup> of discharge rate.

Suthakar *et al.* (2008) developed and evaluated the field performance of a tractor PTO operated manure spreading attachment to a two wheel trailer. The machine consisted of a manure tub to load the manure, an endless chain conveyor for conveying the manure towards the rear end of the trailer and a hydraulically operated spreader

drum to shear off manure. The desired application rate of the manure was observed for the forward speed of 2.31 km h<sup>-1</sup> and the chain conveyor speed of 1.51 m min<sup>-1</sup> with the effective width of 1.20 m and a time saving of 50-60 % when compared to the conventional method. The spread pattern obtained was a flat top profile, which is acceptable for uniform spreading. It can also be used as a trailer by just shifting a door whenever the trailer is required for transportation. The application rate decreased with increase in forward speed of tractor. Minimum (8.13 tonnes ha<sup>-1</sup>) and maximum (18.40 tonnes ha<sup>-1</sup>) application rates were observed for the forward speed of 4.00 km h<sup>-1</sup> and 1.88 km h<sup>-1</sup>, respectively.

Haffer (2009) studied several duster parameters which effect the performance of mechanical date palm pollen delivery. Apparatus consisted of power duster, tube clamp, extension tube and electrostatic sac. Experiment was conducted by varying the delivery tube lengths by 2.5, 5, 7.5 and 10 m and diameters by 10, 15 and 20 mm in manual and power driven dusters. Also percent live pollen, pollen to carrier ratio and throughput efficiency were measured. Analysis of variance indicated that the duster type, tube diameter and tube length had significant effect to its variations for the duster output. Highest percent live pollen of 89.1 was observed at 20 mm dia and 2.5 m long delivery tube. The percent live pollen, pollen to carrier ratio and throughput efficiency were decreased with increased tube length.

Ozbek *et al.* (2010) studied the effects of a prototype liquid manure spreader machine on nitrogen losses and maize yield. A prototype was developed and the effects of liquid manure application and injection on nitrogen loss and maize yield was investigated. Two applicator systems such as manure injection and application were conducted with liquid manure. A plot that is fertilized with mineral fertilizer and an unfertilized control plot were selected for the trials to obtain a comparable data. Results concluded that the effect of both liquid manure applications on maize yield were significant. The plot injected with liquid manure was found to have a higher grain yield of 1382 kg day<sup>-1</sup>. The rate of nitrogen loss in manure injected plots and liquid manure applied plots varied between 4-8 % and 48-68 % respectively. A higher rate of nitrogen loss was observed in surface application of the liquid manure compared to its

application under the soil. Nitrogen loss through surface application was 8.5-12 times higher compared to injection type application.

Sapkale *et al.* (2010) conducted the performance evaluation of tractor operated manure spreader. The spreader used 45 HP tractors through the hitch point with a  $540 \pm$  rpm PTO speed to operate the rotary blades of manure spreader. The distribution pattern was found uniform over the area but a little variation was encountered due to clods in manure. An average field efficiency obtained was 71.55 %. Actual field capacity at a forward speed of  $2.438 \text{ km h}^{-1}$  ranged between  $1.39$  to  $1.47 \text{ ha h}^{-1}$ . A discharge rate of  $5.43$  to  $5.89 \text{ t ha}^{-1}$  at  $2.438 \text{ km h}^{-1}$  was noted. The cost of spreading was reduced to 72 % and time saving of 94 % compared to manual broadcasting.

Chowda reddy *et al.* (2013) developed an animal operated farm yard manure applicator. Several researches reported that the stack piled manure loss was 21 % of its nitrogen to the atmosphere while proper spreading and incorporation reduced to 5 %. Hence a farm yard manure applicator was developed and evaluated for its performance. The applicator was powered by a bullock cart and mainly consisted of a chassis attached frame, main axle, wheels with rubber padding, agitator inside the manure box and power transmission system. Agitator shaft was operated through main axle connected to a gear ratio of 1:3 where the power transmission is completely decided by the animal walking speed. Agitator rotation and manure application rate were also directly proportional to the walking speed of animals.

Singh and Singh (2014) designed and developed an animal drawn farm yard manure spreader. The spreading of manure was performed manually, which involved human drudgery. Hence the idea of transforming the existing bullock carts into FYM spreaders was taken as a base for the study. Accordingly an animal drawn FYM spreader was developed for uniform spreading of manure in the field. It consisted of a manure box, a spiral box for spreading unit and a hitch beam. The auger crushed the lumps and helps in spreading the manure. Chain and sprocket drive was provided for rotating the auger. The developed animal drawn manure spreader was found to have a capacity of 480 kg per hour. At an operational speed of  $2.4 \text{ km h}^{-1}$ , the manure application rate was found out as  $5$  to  $10 \text{ t ha}^{-1}$  with a manure delivery rate of  $0.38$  to  $0.74 \text{ kg s}^{-1}$ .

Jain and Lawrence (2015) conducted the performance evaluation of bullock drawn farm yard manure spreader to spread farmyard manure uniformly at a desired rate in the field. The commonly used organic manure was used for evaluating the performance of spreader. The draft requirement of spreader at no load, partial load and full load condition was found to be 78, 227 and 294 N respectively. Different spreader performances were observed w.r.to different widths of delivery slots of 50-200 mm. The results inferred that application rate was directly proportional to the area of opening of delivery slot and was varied between 6.23 – 13.35 t ha<sup>-1</sup>. Accordingly the manure delivery rates were also varied between 0.38-0.83 kg s<sup>-1</sup>.

Choudhary *et al.* (2016) conducted studies on characteristics of bio slurry and FYM for mechanized application. Spreader performance was mainly dependent on the physical and frictional characteristics of the material. Major characteristics of the manure like bulk density, moisture content, dry matter content, angle of repose and angle of friction were studied for the development of spreader. Physical properties of the manure were studied at different depths varying between 0 to 100 cm. In case of a solid manure spreader, laboratory results concluded that bulk density and moisture content affected the design of manure box and agitating mechanisms. The dry matter content was observed decreasing due to increasing moisture content and affected the flow characteristics of manure. They also concluded that the angle of repose effected the design of hopper and conveying systems.

Jegan *et al.* (2017) analysed the performance of a vermicompost spreader attached with a cultivator. Spreader consisted of three wheels, two hoppers that store the manure and a flow control mechanism to regulate the discharge rate. Manure from the hopper was propelled by wheels to spread the vermicompost over a fallow land uniformly by dropping over the impeller disc. The hoppers placed at some height from the wheel axle allowed the manure to fall on the impeller. An impeller on the output shaft produces centrifugal action which spreads the manure uniformly in the farm land. Chain and sprocket drive was provided to the axle at a proper gear ratio. It gets drive from the ground wheel. Cultivator creates a controlled disturbance of top soil followed by manure application.

Patil and Munde (2017) designed and developed an animal drawn manure spreader cum cart. Since animal power is affordable and accessible to small land holdings, the compatibility of animal cart as a manure spreader was found effective. The spreader consisted of a chassis having two iron wheels, axle assembly, flat and peg tooth agitator, manure box and fastened through yoke and harnesses. A peg tooth type agitator on upper side and flat type agitator on bottom side to a shaft were provided inside the manure box. Drive to the agitator was taken from ground wheel by means of straight bevel gear power transmission in such a way that the rotating speed was 37 rpm in normal working condition. The capacity of the cart was 500 kg. Also reported that on varying the opening area of the cover from 0.04 m<sup>2</sup> to 0.16 m<sup>2</sup>, the application rate varied between 2.46 to 10.06 t ha<sup>-1</sup>. The co-efficient of uniformity for manure distribution varied from 18-20 %. At an operational speed of 2.63 km h<sup>-1</sup> a desired manure application rate of 9 to 10 t ha<sup>-1</sup> was obtained. The draft and power requirement of manure spreader were 637 N and 0.46 Kw respectively. Also effective field efficiency of 84 % was observed at an operational speed 2.51 km h<sup>-1</sup> at a field capacity of 0.21 ha h<sup>-1</sup>.

Kothari *et al.* (2018) designed and developed a cow dung spreader aimed to reduce the manual efforts. To prevent the loss of ammonia and other nutrients from manure proper application of manure to land is essential to prevent the pollution of land. The machine consisted of a trolley, conveyor, centrifugal wheel and a rotating plate. By taking the width, length and height that was available in the field, a trolley was developed to easily move between rows. Conveyor carried the manure in the forward direction and drive is taken from PTO by a ratchet mechanism rotating at 100 rpm. Crushers were provided along with centrifugal wheel, that gets drive from PTO with a chain drive rotating at 135 rpm. Crushers crushed the oversize manure and supplied to centrifugal wheel. Rotating plate at 450 rpm spreads the manure in the field. Change in application rate was observed with change in forward speed of tractor or PTO speed.

Basavraj *et al.* (2018) designed and developed a fertilizer spreading machine. The objective of the study was to develop a simple inexpensive walk behind fertilizer spreader that can be easily pushed by the farmers for spreading fertilizer in the field. It consisted of a hopper, PVC pipes, screw conveyor and a discharge pipe. Power to the

screw conveyor was obtained from chain and sprocket mechanism. When the machine is moving forward direction, motion from the rear axle wheels is transferred to chain and sprocket drive that is connected to a shaft having screw conveyor at both the ends. Fertilizer from the hopper reaches screw conveyor and supplied to the roots of plant by discharge pipes. Discharge rate of the fertilizer was observed as 0.152, 0.076 and 0.038 kg rev<sup>-1</sup> of wheel at full valve, half valve and quarter valve openings respectively.

Singh *et al.* (2018) worked on the laboratory and field evaluation of subsoiler cum vermicompost and soil amendments applicator. A study was conducted to determine the effect of subsoiling and deep placement of organic and inorganic fertilizers at different depths up to 400 mm. Experiment was carried out at three moisture contents of vermicompost, press mud and FYM and for soil amendments like Gypsum, lime, cement and rice husk. The machine was also tested at 250, 300, 350 and 400 mm depths of operation for changes in dry bulk density, specific draft and wheel slippage. Bulk density was found to be uniform throughout the soil profile and observed a maximum of 13.88 %. Draft was measured by mounting a S-type digital strain gauge dynamometer and was found out as 93.29, 65.3, 61.04 and 62.26 kN m<sup>-2</sup> respectively at 250, 300, 350 and 400 mm depths. The field capacity of machine was varied between 0.16 and 0.30 ha h<sup>-1</sup> at two operating speeds 2.0 and 2.5 km h<sup>-1</sup>. Effect of subsoiling and deep placement of fertilizers in mustard crop shown a substantial increase in yield.

#### 2.4 STUDIES ON POWDER FLOWABILITY AND EFFECTS

James and Roger (2000) conducted studies on powder flowability. Flowability is an important parameter that relates to the actual behaviour of the product. Material flowability plays a key role in choosing the feeding hopper angles and conveying systems mainly in powders. During the transfer of powders, storage, blending and compaction the flow characteristics were studied. Flow properties like density, cohesive strength and wall friction were analysed to assess the flow behaviour for different powder characteristics. Study indicated that as the powder particle size increases, the values of HR, compressibility, angle of repose and powder cohesion decreases. When the value of flow function increases gradually, which indicates a decrease of powder cohesiveness and the powder flowability becomes better. Also it was observed that there

existed a non-linear relationship between angle of repose and HR within the experimental range.

Landry *et al.* (2005) evaluated the performances of different conveying systems for manure spreaders and also studied the effect of the hopper geometry on material flow. In this study a prototype land applicator was evaluated with both a scraper conveyor and a system of four augers. The effect of the vertical position of a flow control gate, velocity of the conveying system and inclination angle of the sidewalls for both types of conveying system were considered. Study concluded that the specific energy requirements of both the scraper conveyor and the four auger system were significantly affected by the vertical position of the flow control gate. The characteristic flow rate produced by the four auger system was significantly influenced by the position of the gate and the velocity of the augers. There was also a significant effect of the interaction between gate position and conveyor velocity.

Yang *et al.* (2007) conducted metering and dispensing studies on powders and other free flowing techniques. The effect of power properties and environment on flow, powder conveying, powder metering and delivery, powder delivery in solid free forming were studied. Different methods like pneumatic, volumetric, screw/auger, electrostatic and vibratory methods in both cases were carried out in order to assess the design parameters of machine. The aim of the study was to find the metering and dispensing systems that are effective in providing the spatial arrangement of composition.

## 2.5 STUDIES ON BLOWER MECHANISM

Rex (2000) developed an apparatus for applying agriculture seed/ fertilizer mix to the ground. A container having an agitator and rotating blades were affixed to a housing containing a blowing motor. Agriculture seed/fertilizer mix was poured into the receptacle and blown out through a hose attached to an outlet port on the housing. A nozzle was attached to the end of the hose for effective and uniform application of the materials. A pressurized liquid supply was attached to the nozzle in order to moisten the material as it passes through the nozzle and out over the ground.



Michael (2006) developed a distribution assembly thereby structured to efficiently disperse particulate material of varying sizes and types throughout both a land or water environment. The operational characteristics of the distribution assembly of the system is further enhanced by being structured for use in combination with or independently of a variety of different mobile platforms including land or water travelling vehicles. Also, in some relatively specialized applications, such as tree farms, groves, orchards, etc., a plurality of distribution assemblies were mounted on the same vehicle and concurrently but independently operated.

Yan *et al.* (2010) carried out studies on the methods of determining main geometric parameters of centrifugal fan impeller. The study was aimed at investigating the geometric and performance parameters of centrifugal fans. The performance of the centrifugal fan was assessed by varying the external diameter, exit setting angle, inlet diameter and exit inlet width of the blade to simplify calculations and reliability of design. Research results showed that the exit width of the blade and specific diameter were in linear relation with specific speed. At a constant specific speed of impeller, the specific diameter of forward swept blades was found to be less than radial blades. In case of a forward swept impeller the exit width of blade was taken as 0.8, the ratio of inlet diameter of blade to external diameter of impeller.

Crivello (2011) developed a portable hydroseeding system. It comprised of a housing for slurry, a propellant and an outlet control valve for distributing the slurry. Soil was loosened before seeding and the unit has to be connected with water source and filled with seeds. A drill is attached to mix the slurry that rotates due to centrifugal force created by pressurized water. Outlet valve supplies slurry to the prepared land and hydroseeding typically saves one-fourth cost of laying sod.

Chunxi *et al.* (2011) studied the performance of a centrifugal fan with enlarged impeller. Objective of the research was to study the effect of enlarged impeller on the performance of centrifugal fan. An impeller with standard diameter and two other impellers with an increment in diameter of 5 % and 10 % were chosen. The influence of impeller enlargement was evaluated numerically and experimentally. Numerical simulation indicated a high volute loss in the fan due to larger impeller. Results showed

that the air flow rate, total rise in pressure, shaft power and sound level was increased with decrease in the efficiency with increase in impeller diameter. A high noise level of 1.6 and 2.3 dB for both fans was observed in the noise frequency analysis due to reduced gap between impeller and volute.

Anthony (2014) developed a portable direct current hydroseeder. Hydroseeding is a planting process using a slurry of water, seed, mulch and fertilizer that promotes quick germination and inhibits soil erosion. It consisted of a tank for containing a slurry, a pump and a control valve for regulating the slurry output. Pump was powered by direct current battery charged by a solar panel. The complete assembly was mounted on a wagon which makes it a portable hydroseeder. One half of the tank was filled with water and dry ingredients to flow a slurry. Loosened soils were preferred for applying the slurry.

Lucio *et al.* (2014) predicted the performance of an industrial centrifugal fan incorporating cambered plate impeller blades using a finite volume open-source solver openFOAM. Application of computational methods to industrial fan design processes progressed steadily over the past decade. The finite volume open-source solver openFOAM predicted the performance of industrial centrifugal fans incorporating impeller blades constructed from cambered plate. It characterised the fan using a frozen rotor approach and an arbitrary mesh interface and predicted the fan's pressure rise and efficiency accurately at the peak pressure condition. The analysis within the impeller, volute casing and discharge duct indicated that the modelling approach provided a credible prediction of the fan's secondary flow-field in spite of the presence of extensive separated flow regions, particularly at the peak pressure operating condition. It is a low cost, robust and accurate modelling approach. It provided a practical way for industrial fan designers to engage in the optimisation process when implemented in the open source solver openFOAM.

Ketan and Sunny (2015) studied numerical analysis of centrifugal air blower to understand the flow characteristics at design and off-design conditions. In this study, input and design parameters of centrifugal blower was obtained as per Church and Osborne design methodology developed by Kinnari Shah, Nitin Vibhakar. Fluid model was made as per the design data in PRO-E SOFTWARE. The fluid model was simulated

using computational fluid dynamics (CFD) approach in Ansys (CFX). Performance curves were obtained under different variable inlet parameters like volume flow rate, rotational speed and number of impeller blades. Volume flow rate was changed by changing the mass flow rate at inlet. Comparative evaluation of church and Osborne design methodology (forward curved radial tipped blade) indicated that error in static pressure gradient was higher in Osborne design rather than church design methodology. Better performance parameters were achieved in church design than the Osborne design methodology. Also designed a tongue to reduce back flow and recirculation. Results concluded that the efficiency of both design methodology was closer to the designed point efficiency.

Ahmad (2016) developed a portable pneumatic grain broadcasting unit. The developed portable unit is suitable for broadcasting grains effectively in both dry and germinated grain condition. It was easy to manufacture and to adjust for different agricultural field conditions and operations. The research included testing at three fan peripheral speeds of 1.7, 1.97 and 2.18 m s<sup>-1</sup> respectively and three grain path lengths of 50, 100 and 200 mm. The results inferred that, with a fan speed of 2.18 m s<sup>-1</sup> at an outlet path length of 100 mm resulted the best performance. Also observed that the broadcasting widths with a horizontal fan in both dry and germinated conditions of grain were 10.2 and 8.8 m, respectively. The least values of CV and CU were calculated as 17.33 and 19.11 and the corresponding highest values were 82.67 and 80.89 respectively for dry and germinated grains.

Sani *et al.* (2016) designed a centrifugal blower for a 400kg rotary furnace. The study discussed different theoretical assumptions in the design of a blower and various design parameters involved. A blower was designed to convert driver energy to kinetic energy in the fluid by accelerating the revolving device called as impeller. The diameter of the impeller blade was a design parameter, the larger diameter generated a higher head at a constant impeller speed. As the diameter of the impeller doubled, the energy imparted to the fluid increased to a major extent. The impeller driven by the blower shaft generates velocity at the outer rim directing the fluid away from the impeller vane tips. The fluid energy is a function of its velocity and the velocity accelerates as the fluid passes through the impeller. For optimum performance the ratio of ID to OD varied

between 0.4 to 0.7. Hence it is concluded that the designed blower can be equally adapted for combustion related operations as an air supply system.

Amit *et al.* (2017) conducted CFD analysis of centrifugal pump impeller having different exit blade width, exit diameter and trailing edge blade angle to enhance performance. Computational fluid dynamics (CFD) is a three dimensional simulation done to optimize the pressure head, efficiency and power required by changing impeller exit blade width, exit diameter, trailing edge blade angle and at different rpm. In this study initially the geometry of centrifugal pump impeller was created in ANSYS blade gen design modeler and further mesh in ANSYS turbo grid meshing tool and finally CFD analysis was done in ANSYS CFX. Results indicated that the increase in the blade width at the exit of the impeller increased the performance of pump impeller. Also observed that the decrease in the extension of shroud of the impeller increased the performance of pump impeller in all the parameters. When increased the blade angle at the trailing edge blade, the performance of pump impeller was increased.

Beena *et al.* (2017) designed and developed a centrifugal blower that are widely used in turbomachines equipment. Designing of blowers follows certain optimum design parameters to suit the requirement of individual blowers. Each component of blower has different set of rules to achieve estimated flow rate for designing the impeller. Objective of the study was to clearly state the design methodologies and to develop a unique design that can achieve better design performance. The design was based on the fundamental concepts and other minimum assumptions. Study was carried out to determine the effect of design parameters on pressure ratio, flow rate and their inter dependency in the design. A blower considering the present design parameters, another blower on the basis of industrial design parameters was developed with standard blower manufacturing unit. Both the blowers with different designs were compared on experimental performance analysis and numerical analysis to check the flow parameters as per standard. The results suggested that the present design with same pressure head had better efficiency and high flow rate compared to industrial one.

Abubakar *et al.* (2018) designed and developed a blower for downdraft biomass gasifier. Lack of adequate blower design and inadequate supply of air were the major causes for gasifier failures. Research was undertaken to design the blower for a batch

type downdraft gasifier using both analytical and numerical methods. A blower was constructed using a mild steel connected to a 0.5 HP electric motor. A 15 mm diameter mild steel rod was selected to withstand the torsional and bending loads on the shaft against the high speed rotation and weight of the blower impeller. Geometrical parameters of the impeller, blower physical characteristics and performance parameters were calculated. Eight blades with blade angles of  $42^\circ$  and a minimum impeller inlet diameter of 186 mm were used. Power required to run the blower was found out as 221W and total efficiency was 85.1 %.

## 2.6 COST ECONOMICS OF MANURE SPREADER

Kumara and Dwivedi (2010) analysed the economics of organic farming over conventional farming in India. Economic study of organic farming was carried out in different crops to assess the production, productivity, energy inputs and net income levels. Results concluded that the production cost of organic farming is lower in both cotton and sugarcane crops. The cost of production per quintal of paddy under organic farming was 8 % lower than the conventional farming. Sugarcane yield per acre was found out as 12 % higher in organic farming than the conventional. Also the efficiency levels of production system are lower in organic farming when compared to conventional farming. The results concluded that there was immense scope for organic farming in India. Study suggested the creation of markets for organic foods, encouraging organic growers and increasing research and development in organic farming are essential to promote the organic cultivation among farming.

Rahul batta *et al.* (2015) carried out field and economic studies of a tractor operated manure spreader with rear vertical rollers. The moisture content and density of manure used for evaluation varied from 30-40 % (w.b.) and 430-480 kg m respectively. The loading capacity of machine varied from 1.0-1.2 tonnes. The forward speeds are varied between 2.0 to 7.0 km h<sup>-1</sup> keeping the engine rpm at 1400, 1500 and 1600 during operation. A mean swath width of 2.3-4.0 m was obtained for the manure spreader. The field capacity and mean fuel consumption varied from 0.11 to 0.55 ha h<sup>-1</sup> and 5.35-7.80 l h<sup>-1</sup>, while the manure application rate during field experiments varied between 10.58-36.37 t ha<sup>-1</sup>. Using a tractor operated manure spreader the time and cost

incurred in spreading manure was saved by 66.17 % and 50.43 % compared to traditional techniques.

# MATERIALS AND METHODS

## CHAPTER III

### MATERIALS AND METHODS

The methodology adopted for the development and performance evaluation of a tractor powered manure pulverizer cum applicator are detailed in this chapter. The constructional details, laboratory testing and field evaluation of the developed unit are explained. The components were designed using SOLIDEDGE software for easy modelling and scaling. The method followed to optimize the varying levels of parameters for effective performance of the machine is narrated. Finally, the standard used for the calculation of cost economics of manure pulverizer cum applicator is reported.

#### 3.1 MANURE REQUIREMENTS OF DIFFERENT SOILS

As agriculture is facing the problems of soil degradation, loss of fertility and soil health, the use of farm manure and organic materials is the way out. A larger portion of nitrogen is made available as and when the manure decomposes. Availability of potassium and phosphorus from manure is similar to that from inorganic sources. Application of manure improves soil fertility therefore there is wide scope to its application.

The application rate of various manures was observed for different crops according to the agronomic conditions of Kerala state. The components of the machine were developed to suit the various dosages of manure without much variation in the distribution efficiency.

**Table 3.1 Nutritional composition of manure**

<b>Type of manure</b>	<b>N</b>	<b>P<sub>205</sub></b>	<b>K<sub>20</sub></b>
Cow dung	1.09	0.82	0.70
Neem cake	5.00	1.10	1.50
Goat faecal pellets	3	1	2

...(Pabitra, K.M., 2011)



### 3.2 PHYSICAL PROPERTIES OF MANURE

Physical properties of the manure directly affect the design of blower and manure dissipation. The important physical properties are moisture content, bulk density, angle of repose, terminal velocity and coefficient of friction of pulverized manure. The detailed procedure for measurement of physical properties of pulverized manure are described below.

#### 3.2.1 Bulk density

Bulk density affects handling of manure in the machine. The bulk density of a powder is the ratio of the mass of an untapped powder sample and its volume including inter particulate void volume. The bulk density is expressed in kilogram per cubic metre.

A 50 ml empty cylinder ( $w_1$ ) is weighed and measure the volume of the cylinder. Allow the manure sample to flow freely into the measuring cylinder until it overflows. Carefully scrape the excess powder from the top of the cylinder. The cylinder and the sample are then weighed ( $w_2$ ). Repeat this procedure for 3-5 replications. The bulk density is found out by measuring the weight of the sample by volume of the cylinder. The bulk density of the sample is calculated from the following equation:

$$\text{Bulk density, } D_b = \frac{W_2 - W_1}{V} \quad \dots(\text{Landry } et al., 2004)$$

Where

$W_2$  = the weight of the cylinder and sample (g)

$W_1$  = the weight of the cylinder (g)

$V$  = the volume of the cylinder ( $\text{cm}^3$ ) =  $\frac{\pi}{4} \times d^2 \times h$

#### 3.2.2 Tapped density

The tapped density is an increased bulk density attained after mechanically tapping a container containing the powder sample. Tapped density of a powder is the ratio of the mass of the powder to the volume occupied by the powder after it has been tapped for a defined period of time. The tapped density of a powder represents its random dense packing.

Initially measure the weight of the cylinder ( $w_1$ ). The cylinder is filled with manure and tapped continuously to get a constant volume. Measure the final height of the cylinder and calculate the tapped volume.

$$\text{Tapped density, } D_t = \frac{W_2 - W_1}{V}$$

Where,

$W_2$  = the weight of the container and sample (g)

$W_1$  = the weight of the container (g)

$V$  = the volume of the container ( $\text{cm}^3$ )

### 3.2.3 Moisture content

The moisture content of the manure was determined by using hot air-oven. 5g of sample was weighed and taken in the tare porcelain dish ( $w_1$ ). The sample was placed in the oven at  $105^\circ \text{C} \pm 2^\circ \text{C}$  for 24 h, then it was cooled in the desiccators. Oven dried sample weight was noted ( $w_2$ ). Moisture content is measured in dry basis and is expressed using the formula:

$$\text{Percent moisture content} = \frac{W_1 - W_2}{W_2} \quad \dots (\text{Sahay and Singh, 2001})$$

Where,

$W_1$  – initial weight of the sample

$W_2$  – final weight of the sample

### 3.2.4 Angle of repose

The angle of repose is the angle between the base and the slope of the cone formed on a free vertical fall of the mixture to a horizontal plane. It is the ability of the product to flow and each product has its own angle of repose. The size, shape, moisture content and orientation of the particles influence the angle of repose.

It is measured using an apparatus consisting of a metal conical funnel with an open bottom, fixed on a metal stand and below an iron disc on which various diameters were marked. Sample is filled in the funnel and allowed to heap freely on iron disc from

open bottom. The height and diameter of the cone are measured. Angle of repose was found out using the equation,

$$\text{Angle of repose, } \theta = \tan^{-1} (2h/d) \quad \dots(\text{Sahay and Singh, 2001})$$

Where,

$\theta$  = angle of repose in degree

h = height of the cone

d = diameter of the plate

Angle of repose of the pulverized manure plays an important role in deciding the flow angle while fabricating the conveying chamber for pulverizer cum applicator. Taking higher value of angle of repose results in more freely flowing of powdered manure whereas for lesser value of angle of repose than required results in clogging.

### 3.2.5 Coefficient of friction

The coefficient of friction apparatus consists of a horizontal plane and a bottomless open container and a pan. Known weights of manure were taken in the container. The weights were added in the pan and at the instant at which the pan weight exceeds the manure; the container starts to slide movement. The coefficient of friction measures both external and internal contact of manure with horizontal plane. Hence, angle of friction is more important for sliding the manure over a sheet as compared to angle of repose (Singh and Singh, 2006). Following equation was used for determination of coefficient of friction as:

$$\mu = \frac{F}{N} \quad \dots(\text{Singh and Singh, 2014})$$

Where,

$\mu$  = coefficient of friction,

F= frictional force (force applied) and

N= normal force (weight of the manure).

### 3.2.6 Terminal velocity

Terminal velocity plays an important role in optimizing the blower rpm to dissipate the manure. In handling the powdered manure through a blower, air is used as a carrier for dissipation. When the air velocity is greater than the terminal velocity of manure, it lifts the particles such that air velocity could be adjusted to a point just below the terminal velocity.

Pulverized manure is a mixture of fine dust particles which have a very less terminal velocity and settling time. Although a 5 mm sieve is used in the pulverizer, due to the rotational speed of the blade it resulted in a very fine mixture. It is difficult to find the terminal velocity of powdered manure because of its fineness, lack of facilities and its unhygienic nature. So various studies were referred and came to a conclusion to design and develop a laboratory model of blower.

## 3.3 PERFORMANCE PARAMETERS AFFECTING PULVERIZER CUM APPLICATOR

### 3.3.1 Field capacity

It is the actual area covered by the machine based on its total time consumed and actual working width under field condition. It is expressed in terms of area covered per unit time of operation. It is calculated by

$$\text{Field capacity (ha h}^{-1}\text{)} = \frac{\text{Actual area covered}}{\text{total time consumed}}$$

### 3.3.2 Field efficiency

Field efficiency is the actual average rate of coverage by the machine, based upon the total operation set time. It is a function of the rated width of the machine, speed of operation and the amount of time lost during the operations. Effective field capacity is usually expressed as hectare per hour (Kepner *et al.*, 2005).

$$\text{Field efficiency (\%)} = \frac{\text{Actual field capacity}}{\text{theoretical field capacity}}$$

### 3.3.3 Discharge rate

Discharge rate is the amount of manure discharged from the blower outlets. It is calculated as  $\text{kg h}^{-1}$  or  $\text{kg ha}^{-1}$ . Discharge from the blower outlets depends on the pulverizer output, feed regulator opening and blower rpm. Discharge rate is measured by varying the openings of feed regulator at two stages i.e., at half and full openings. Laboratory procedure can be adopted to calculate the discharge from each outlet or as a whole.

Each outlet is provided with a polythene bag or a bucket to collect the manure and weighed at the end of the test. Sum of the discharges from 3 outlets gives the discharge rate of developed manure applicator. Also output from all 3 outlets should be individually weighed to check for more or less uniformity in discharges.

### 3.3.4 Coefficient of uniformity

Manure distribution tests were done in laboratory when the applicator was static and at fixed height. The applicator was operated at two discharge rates by regulating the flow control valve. Coefficient of uniformity is slightly dependent on the opening in feed regulator as the change in input volume changes the uniformity at the outlets. The power for the applicator was derived from tractor p.t.o.

The coefficient of uniformity(CU) is used to assess the uniformity of the manure distribution through all the 3 outlets. It was calculated by dividing the standard deviation of collected manure in every output by the average of total collected manure(IS: 16122-2, 2015).

$$CU = 100 \times \frac{S}{X}$$

$$S = \sqrt{\frac{\sum(X_i - X)^2}{n-1}}$$

$$x = \frac{\sum X_i}{n}$$

Where,

CV: Coefficient of variation, expressed as percentage

$x_i$  : Weight of manure in the  $i_{th}$  outlet

n : Number of outlets

S : Standard deviation of the weights collected at outlets

x : Average/mean volume collected per outlets

### 3.3.5 Degree of pulverization

The finer the particles size the more easy it becomes to decompose in soil. Pulverization performance is evaluated by calculating mean width diameter (MWD) of the manure samples. By varying the input engine rpm and interchanging the pulleys the blade rotation increases which increases its pulverization capacity.

It is calculated by performing sieve analysis with standard sieves in the mechanical sieve shaker (Plate.3.2). The sieves used for fine sieve analysis are 2mm, 1mm, 600, 425, 300, 212, 150 and 75 IS sieves. Weight of sample retained on each sieve is noted.

Degree of pulverization is measured by

$$MWD = \sum_{i=1}^n \frac{W_i}{W} D_i$$

Where,

$W_i$  = weight of the soil gathered in each grade

$W$  = total weight of the soil sieved

$D_i$  = mean diameter referred to each grade

n = number of grades

### 3.3.6 Swath width

Swath width is equal to the number of outlets multiplied by the outlets spacing. The spacing between the outlets was kept constant as 60 cm following the package of practices, Kerala Agricultural University. Flexible hoses are preferred in order to make outlets flexible and to prevent bending or breakage when operated in uneven terrains. Flexible hoses are suitable for reaching various row spacings without encountering any

sharp corner. The outlets are provided as close as possible to the ground surface in order to reduce the drift.

**Table 3.2 Spacing of various vegetables**

Sl. No.	Crop	Spacing (row to row × plant to plant) cm <sup>2</sup>
1	Tomato	60×60
2	Okra	60×60
3	Brinjal	60×60
4	Chilli	45×45
5	Cauliflower	60×45
6	Carrot	45×10
7	Beetroot	45×15-20
8	Radish	45×10

...(KAU POP, 2016)

### 3.3.7 Fuel consumption

It was measured by top up fill method. The fuel tank was filled to full capacity before the testing on a levelled surface. After completion of test operation, the amount of fuel required to top up again is the fuel consumption for the test duration. It is expressed in litre per hour.

### 3.4 STATISTICAL ANALYSIS

The data obtained were statistically analysed by 4-Factorial Completely Randomized Design (FCRD) using Design Expert (v 10) software. The effect of the selected machine and manure parameters over the performance of developed unit were noted. The analysis of variance (ANOVA) and mean table for different parameters were tabulated and the level of significance was reported.

### 3.5 KAU MANURE PULVERIZER

Manures are pulverized especially for making pot mixture and for easy application as farmyard manure (FYM). The machine consists of an electric motor, pulverizing drum, transmission unit, feeding chute, rotating blade, sieve and stand. Dried manure reaches the pulverizing drum from the feeding chute and rotating blades

help in pulverizing the manure due to impact and shear force. Manure remains over the sieve until it attains a size smaller than the size of the sieve.

### **3.5.1 Prime mover**

A single phase ac induction motor with nominal power of 2 hp, working voltage 230v 50 hz available with the nominal speed of 1440 rpm was used as a prime mover. Electric motor actuated the shaft consisting of blades through the use of two double v-belt pulleys.

### **3.5.2 Pulverizing drum**

The process of pulverizing the dried manure took place in the pulverizing drum by impact and cutting forces of rotating blades. The drum was made up of 5 mm thick M.S sheet and had a diameter of 520 mm with a height of 300 mm. The total capacity of the drum was 0.064 m<sup>3</sup>. The drum housed the blades fixed at the bottom of the shaft, bearings and a sieve at the bottom. It had a top cover made of M.S sheet of 1 mm thick, 2/3rd of the top cover was fixed and 1/3rd facilitated an opening for feeding dried materials.

### **3.5.3 Transmission unit**

Power from the electric motor shaft was transmitted to the parallel shaft containing blades using the transmission unit. The unit consisted of two double V-belts pulley of size 10 cm, two B39 V-belts and a M.S shaft of  $\phi$  35 and length 40 cm. The shaft was fixed inside the drum using two plummer blocks with ball bearings. Plummer blocks were fixed at a distance of 14 cm on an angle iron frame welded to the drum. Rotating blades were fixed at the end of the shaft. A square key of length 6.3 cm was inserted to restrict the relative motion of the pulley and shaft. A lock screw was provided at the bottom to hold the shaft in erect position.

### **3.5.4 Feeding chute**

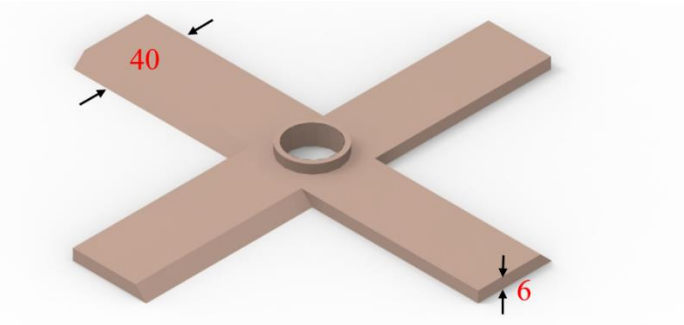
Various dried manures were fed manually through the feeding chute to the pulverizing drum. The feeding chute was trapezoidal in shape having 56.5 cm length and top and bottom width as 72 cm and 30 cm respectively. It was made of a M.S plate



of thickness 6 mm. A M.S angle iron 20 x 20 x 2mm was welded at top of the chute and 25 x 25 x 5mm at the bottom to hold the plate in firm condition.

### 3.5.5 Rotating blade

Rotating blades were responsible for pulverizing various dried manures. The rotary shaft was fitted with four blades at the end, inside the pulverizing drum. It had a length of 22 cm and width 4 cm and was made up of end flat of 6 mm thick. The blades were fitted at the bottom of the shaft with the help of a nut and the clearance could be adjusted. It was sharpened on one side at an angle 45°.



All dimensions in mm

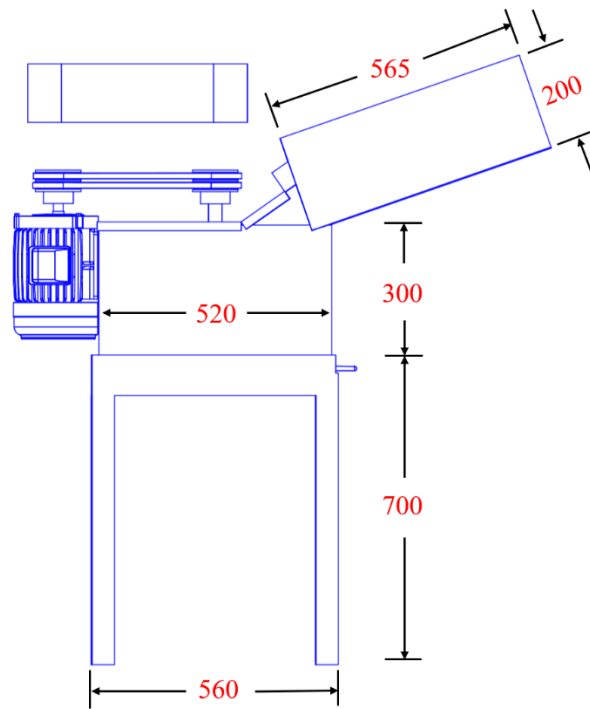
**Fig. 3.1 Rotating blade**

### 3.5.6 Sieve

The pulverized manure was guided to the hopper through the sieve provided at the bottom of the drum. A 10 mm sieve was used for the operation. It was supported by sheet of size 52 x 52 x 0.4 cm and was welded on the supporting frame just below the rotating blades. The materials got crushed between sieve and rotating blade to get the fine manure.

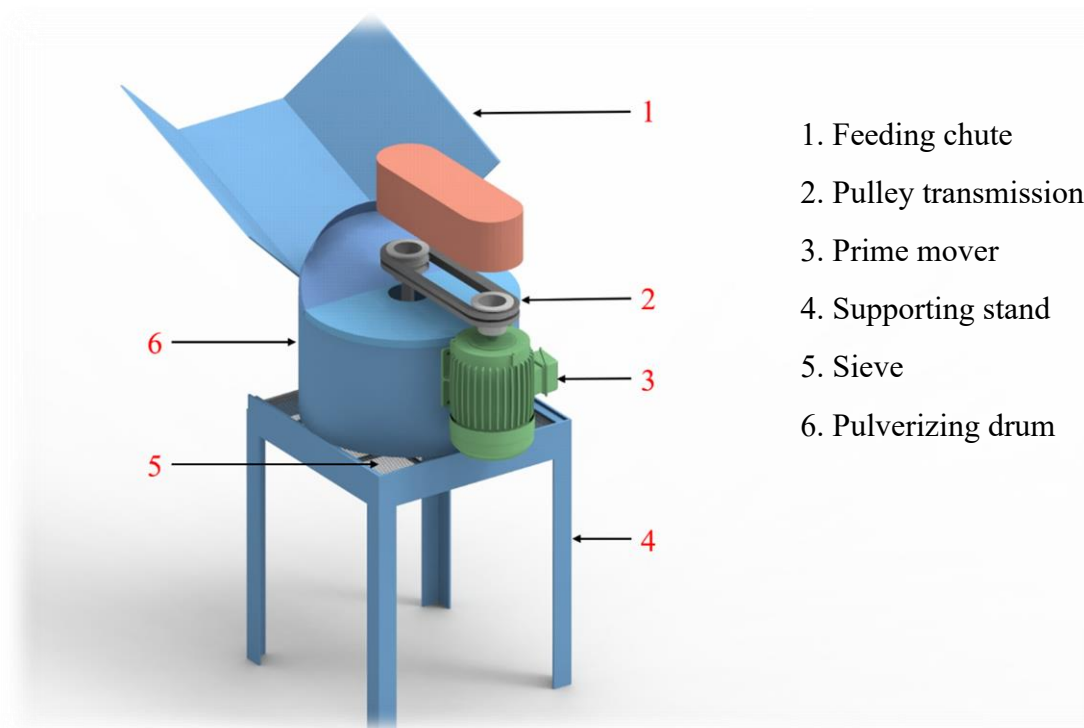
### 3.5.7 Supporting stand

The entire pulverizing unit *viz.* Electric motor, feeding chute, pulverizing drum, transmission unit and sieve were supported using a stand. It was made with four mild steel iron angles of size 50 x 50 x 6 mm with a height of 700 mm. Overall dimensions of the stand are 560 x 560 x 700 mm.



All dimensions in mm

**Fig. 3.2 Elevation view of KAU manure pulverizer**



**Fig. 3.3 KAU manure pulverizer**

### 3.6 COST ECONOMICS

Fixed cost and variable cost of the tractor drawn manure pulverizer cum applicator was calculated as per the procedure described by IS: 9164-1979. From the field capacity of the machine the cost of operation per hectare and cost of operation per hour was calculated.

Also conventional practices of manure application was studied and capacity of the manual labours (man-hours ha<sup>-1</sup>) is determined. Based on this, the costs incurred in both conventional and mechanical manure application can be compared.

#### 3.6.1 Break even point

The break-even point is defined as the point at which neither profit is made nor loss incurred. The break-even point is equal to the annual fixed cost divided by difference between the custom rate per hour and the operating cost per hour. The break-even point was calculated as

$$\text{Break-even point, h yr}^{-1} = \frac{\text{AFC}}{\text{CF}-\text{C}}$$

Where,

AFC = Annual fixed cost for the machine, Rs. yr<sup>-1</sup>

CF = Custom fee, Rs. h<sup>-1</sup>

C = Operating fee, Rs. h<sup>-1</sup>

CF = (cost of operation h + 25 % overhead charges) + (25 % profit over new cost)

#### 3.6.2 Pay back period

It is the number of year it would take for an investment to return its original cost through the annual cash revenue it generates, if the net cash revenues are constant each year. the payback period is calculated as

$$\text{PBP} = \frac{\text{IC}}{\text{ANP}}$$

Where,

PEP = Payback period, yr

IC = Initial cost of the machine, Rs.

ANP = Average net annual profit, Rs yr<sup>-1</sup>

ANP = (CF - C) AU

AU = Annual use, h yr<sup>-1</sup>

### 3.6.3 Benefit cost ratio

Benefit cost ratio should be more than one

Benefit cost per hectare = cost of manual application - cost of machine application

Therefore,

$$\text{Benefit cost ratio, Rs. ha}^{-1} = \frac{\text{Benefit cost}}{\text{Cost of machine application}}$$



**Plate 3.1 Determination of moisture content by hot air oven**



**Plate 3.2 Sieve analysis by mechanical sieve shaker**



**Plate 3.3 Anemometer and tachometer**

### 3.7 SELECTION OF MACHINE PARAMETERS

The parameters of prototype manure pulverizer cum applicator such as speed of tractor, speed ratio between engine rpm and blower rpm and size of valve opening influenced the application rate of manure pulverizer cum applicator. The parameters are optimized to achieve the selected level of application rate.

#### **3.7.1 Speed of tractor (S)**

Speed of the tractor influences the application rate of manure in the field. Varying the speed of tractor w.r.to blower rpm results in varied application rate. Hence the speed of the tractor can be optimised to achieve the required application rate of manure.

#### **3.7.2 Speed ratio between engine rpm and blower rpm (E)**

Gearbox helps in increasing the speed ratio between the engine p.t.o. and blower. At various levels of blower rpm, varied application rate is obtained along with changing type of manure.

#### **3.7.3 Size of valve opening (V)**

By changing the size of the valve opening above the blower, the application can be varied. Machine is operated at two conditions of valve openings (full and half open) such that feed into the blower changes resulting in a varied application rate of manure.

### 3.7.4 Levels of variables

**Table 3.3 Description of levels of variables**

Sl. No.	Description of variables	Selected levels	No. of levels
1	Speed of tractor, km h <sup>-1</sup> (S)	1.5(S <sub>1</sub> )	3
		2(S <sub>2</sub> )	
		2.5(S <sub>3</sub> )	
2	Engine rpm of tractor (E)	1500(E <sub>1</sub> )	3
		2000(E <sub>2</sub> )	
		2500(E <sub>3</sub> )	
3	Size of valve opening, (V)	Full(V <sub>1</sub> )	2
		Half(V <sub>2</sub> )	
4	Type of manure (T)	Cow dung(T <sub>1</sub> )	3
		Goat faecal pellets(T <sub>2</sub> )	
		Neem cake(T <sub>3</sub> )	

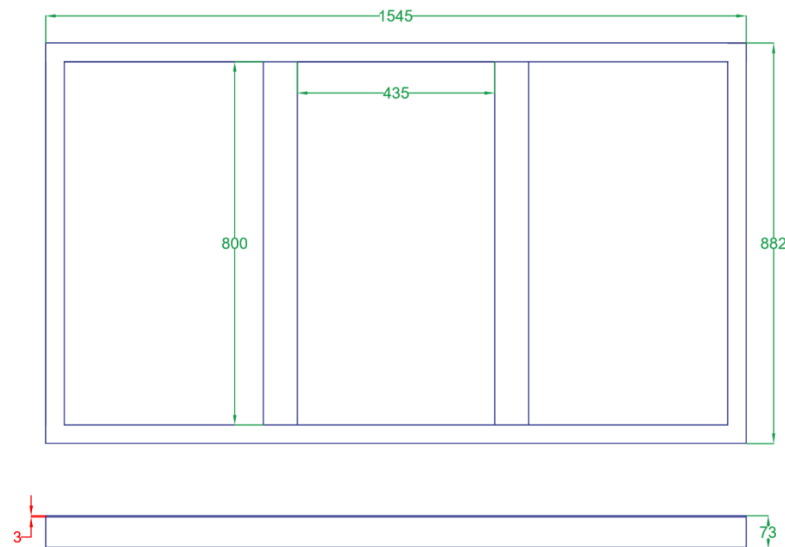
Replications = 3

Total no. of treatments =  $3 \times 3 \times 2 \times 3 \times 3 = 162$

### 3.8 DEVELOPMENT OF FRAME AND HITCHING SYSTEM

The complete setup *viz.*, pulverizer, gearbox and blower should be supported by a frame and hitching system for making it a tractor drawn implement. The entire setup is run by taking input from the tractor p.t.o shaft by means of a 3-way right angle gearbox. So a platform is required to mount the gearbox and support the corresponding blower unit.

Anticipating the gearbox and blower dimensions the dimensions of the supporting frame is decided. A mild steel channel of 75×40×3 mm is used to make the frame. Two pieces of 1500mm length and 4 pieces of 800mm are cut and welded in rectangular shape with two supports in middle as shown in Fig.3.3.

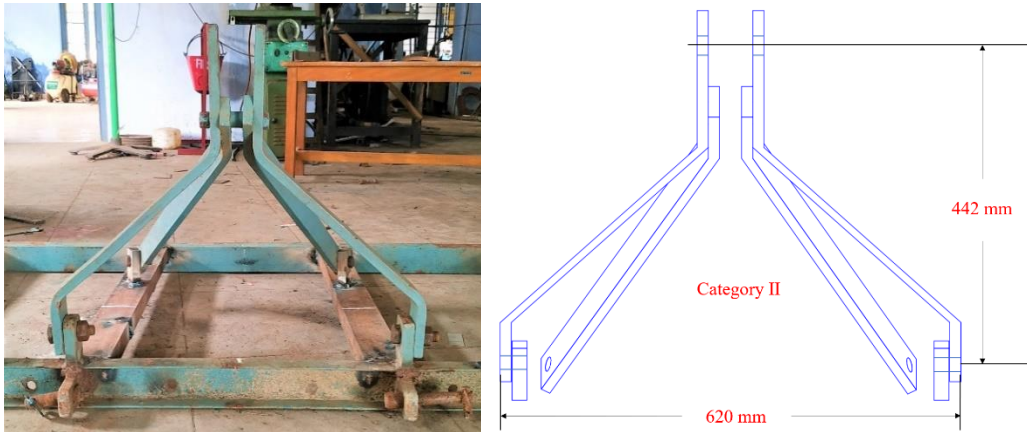


All dimensions in mm

**Fig. 3.4 Elevation view of supporting frame**

Development of hitching system follows IS: 4468-2005 (agriculture wheeled tractors-rear mounted 3-point linkage) and IS: 4931-1995 (agricultural wheeled tractors-rear mounted p.t.o). A standard hitch system is chosen to suit both medium and large tractors. Enough space is provided beneath the supporting links such that accommodating pulverizer unit, gearbox and blower is easy. The mast height of the hitch system is 442 mm which falls in Category II.



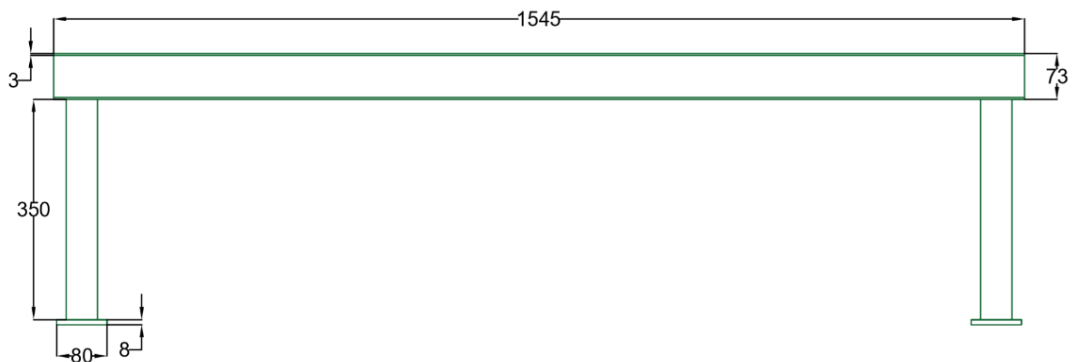


**Plate 3.4 Category II hitching system**



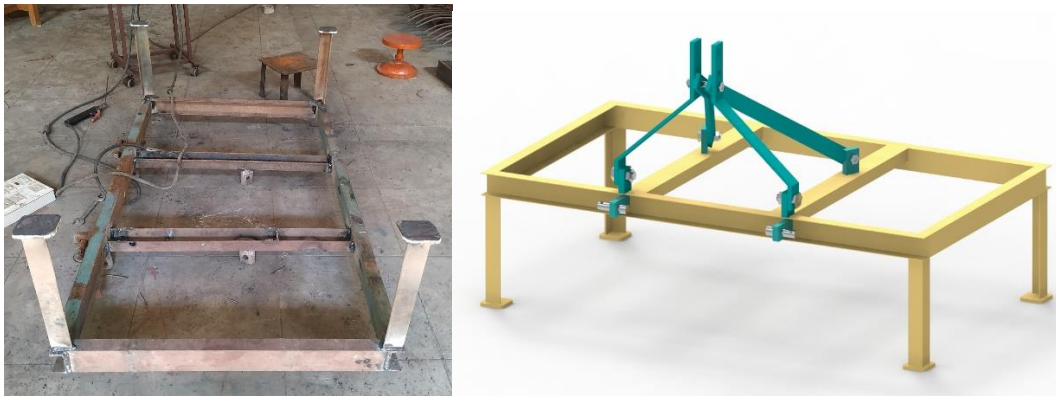
**Plate 3.5 Lowest reach position of tractor lower links**

The maximum distance a tractor lower hitch can be lowered is measured i.e., less than or equal to 300 mm from the ground level.



**Fig. 3.5 Elevation view of supporting stand**

Also, the gearbox and applicator unit requires enough space for working and maintenance. So considering the error in elevations, four legs each 350mm length is decided. Mild steel angle of dimension 50×50×5 mm is chosen. A mild steel flat of 8mm thick is cut into a square 80×80 mm size is welded at the end of the legs.



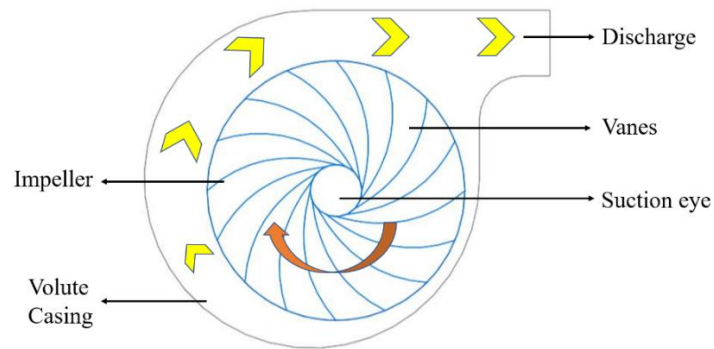
**Fig. 3.6 Supporting frame and 3-point hitch system**

### 3.9 DESIGN AND DEVELOPMENT OF A LABORATORY BLOWER MODEL

In handling the powdered manure through a blower, air is used as a carrier for dissipation. When the air velocity is greater than the terminal velocity of manure, it lifts the particles such that air velocity could be adjusted to a point just below the terminal velocity. Pulverized manure is a mixture of fine dust particles which have a very less terminal velocity and settling time. It is difficult to find the terminal velocity of powdered manure because of its fineness and lack of facilities. So various studies were referred and came to a conclusion to design and develop a laboratory model of blower.

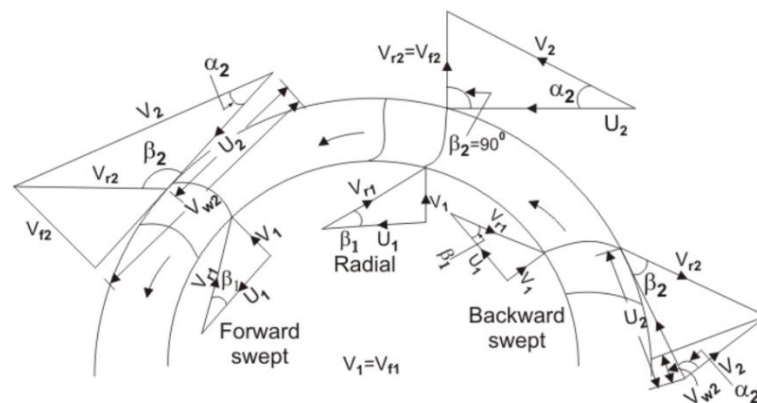
A typical centrifugal blower consists of an inlet for suction, an impeller to impart energy to the feed and an outlet for discharge. A spiral casing known as volute chamber, where the feed gains the energy in terms of both velocity and pressure rise at the end of the impeller. Feed enters the impeller axially through the inlet which provide a slight acceleration to the air before it enters the impeller.

Centrifugal fans contribute low air flow rates and high pressures with flow perpendicular to blower axis. Air enters around centre of the fan and exits around the outside. Typical applications for centrifugal fans include air handling units, process heating and cooling, electronic cooling and boiler combustion air.



**Fig. 3.7 Blower working principle**

There are three different types of blades of an impeller of a centrifugal blower namely forward swept blades, radial swept blades and backward swept blades. Depending upon the flow rate required, shape of the blade can be varied.



**Fig. 3.8 Inlet and outlet velocity triangles for various impeller**

In case of a forward swept impeller, the curvature of the blade is in the direction of the rotation. The forward swept blades are used where large flow rates are required, relatively large flow rates and higher pressure rise is required as compared to backward swept blades. Whereas radial blades are preferred where the fluid is, that is air used contains more impurities and dust. This is because of the fact that these are less prone to the blockage and they work more efficiently with the dust laden gas.

In case of a backward swept impeller, the curvature of the blade is in the direction of rotation. These are capable of creating negative pressure at the eye that helps in suction also providing a higher velocity and pressure at the outlet. Design and

performance of different impellers are evaluated in the study in order to select an impeller that provides a maximum suction at the eye and maximum throw velocity at the outlets.

### 3.9.1 Theoretical design assumptions

Design specifications such as volumetric flow rate, impeller diameters and number of blades can be designed following standard ASME codes and modifications can be made from the results obtained during practical observations.

$$\text{Column length} = \text{pitch} \times \text{rpm}$$

$$\text{Flow rate} = \pi \times (\text{radius})^2 \times \text{column length}$$

...(Sani *et al.*, 2016)

Standard pitch of the impeller describes how densely its blades are set around it. It is the ratio of circumference of the impeller to the number of blades. Standard pitch of the impeller usually varies between 7.5 to 10.5 cm. By assuming the impeller rpm and varying its radius theoretical volumetric flow rate can be obtained.

Let pitch = 7.5 cm, rpm = 1000, diameter = 20 cm

$$\text{Then, column length} = 7.5 \times 1000 = 7500$$

$$\text{Flow rate} = \pi \times (10)^2 \times 7500 = 2.4 \text{ m}^3 \text{ min}^{-1}$$

Assuming maximum pitch and impeller diameters will result in a volumetric flow rate more than  $5 \text{ m}^3 \text{ min}^{-1}$  which can then be correlated with practical observations.

### 3.9.2 Blade diameters

From the optimum performance specification it is stated that the ratio of the internal diameter to the external diameter is to fall between 0.4 to 0.7 as stated in the ASME code.

$$\text{i.e., } 0.4 < D_1/D_2 < 0.7$$

...(Sani *et al.*, 2016)

For the design of paddle impeller,  $D_1 = 100 \text{ mm}$ ,  $D_2 = 200 \text{ mm}$  i.e.,  $D_1/D_2 = 0.5$

Straight 6-blade impeller,  $D_1 = 80 \text{ mm}$ ,  $D_2 = 200 \text{ mm}$  i.e.,  $D_1/D_2 = 0.4$

Straight 4-blade impeller,  $D_1 = 60$  mm,  $D_2 = 200$  mm i.e.,  $D_1/D_2 = 0.3$

Radial blade impeller,  $D_1 = 100$  mm,  $D_2 = 200$  mm i.e.,  $D_1/D_2 = 0.5$

### 3.9.3 Number of blades

The optimum number of blades which gives the best efficiency can be chosen from theoretical design considerations or by experience. Increase in a number of blades increases flow coefficient and efficiency, due to better guidance, which reduces losses.

From ASME code, for optimum performance the number of blades is given by

$$C = \frac{8.5 \sin \beta/2}{1 - D_1/D_2} \quad \dots(\text{Sani } et \text{ al.}, 2016)$$

Then in case of paddle type impeller,  $c = 8$  blades ( $\beta_2 = 28$ )

Straight 6-blade impeller,  $c = 6$  blades ( $\beta_2 = 20$ )

Straight 4-blade impeller,  $c = 4$  blades ( $\beta_2 = 20$ )

Radial blade impeller,  $c = 8$  blades ( $\beta_2 = 28$ )

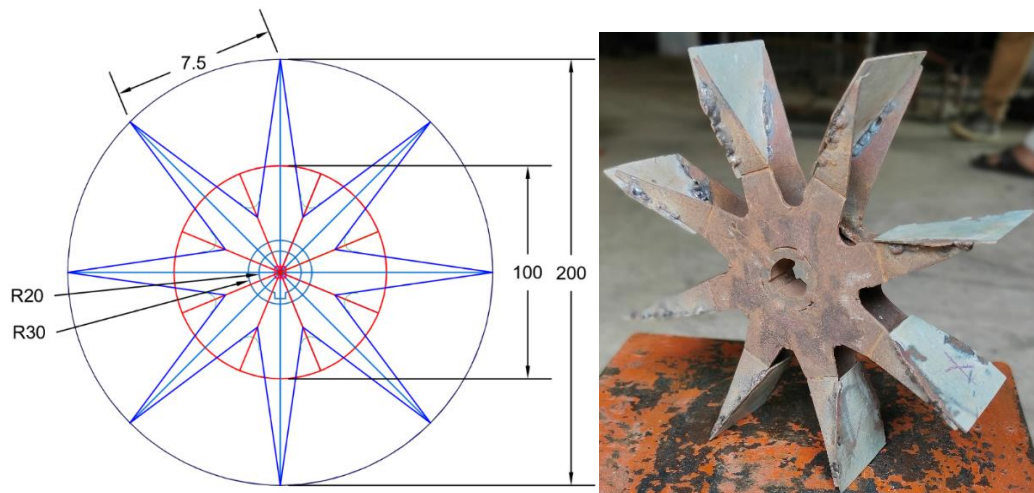
## 3.10 DEVELOPMENT OF IMPELLERS

Bulk density of the manure plays an important role as the strength of the blade should overcome the density which is ranging between 0.480 to 0.505 g cm<sup>-3</sup>. Negative pressure or suction is an important parameter that helps in suction of pulverized manure at the eye of the impeller. By increasing the number of blades on the impeller, the suction velocity at the eye can be increased but results in clogging and reduced discharge. The impeller must overcome the clogging between the blades in order to dissipate the manure. So an impeller with permissible number of blades can be chosen depending upon design criteria and practical observation.

### 3.10.1 Paddle type impeller

A paddle type impeller is made up of mild steel sheet of 2mm thickness with inner and outer diameters as 100 and 200 mm. To meet the design criteria, two pieces of eight blades each with a pitch of 7.5mm and making 45° angle between the blades is marked. The stars are bent to 28° with the horizontal and arranged in opposite direction. To fit

the prime mover shaft (AC motor) and to hold the opposite stars a hub of 20mm diameter is made at the center of the impeller. It provides an end to end clearance of 50mm between the bent blades. An extended trapezoid of dimension 50×25×32.5mm is welded between the gaps making it a paddle type impeller.

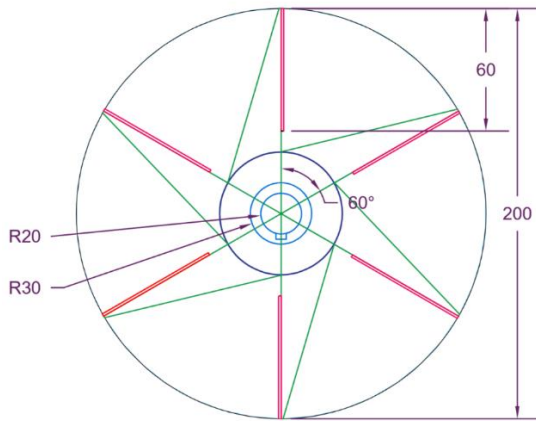


**Fig. 3.9 Elevation view**

**Plate 3.6 Paddle type impeller**

### 3.10.2 Straight 6-blade impeller

In the above case, a paddle type impeller provided with 8 blades resulted in lesser suction and discharge. To overcome these negative effects a straight 6-blade impeller with enough space between the blades that can accommodate and discharge manure effectively is considered. It is made up of mild steel sheet of 2 mm thickness with inner and outer diameters as 80 and 200 mm. Six lines passing through the origin at an angle of 60° between them is marked on the plate. And correspondingly six blades of dimension 60×50 mm are welded at 90° to blade. A hub of 20 mm ID is fixed at the center.



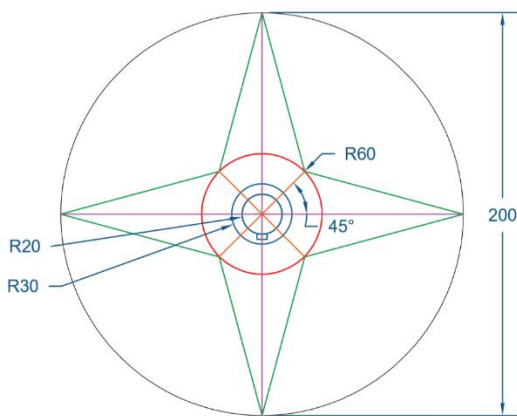
**Fig. 3.10 Elevation view**



**Plate 3.7 Straight 6-blade impeller**

### 3.10.3 Straight 4-blade impeller

Results from straight 6-blade impeller showed good suction and dissipation. Decreasing the number of the blades decreases the air velocity from outlets but at the same time it provides enough space to accommodate a large quantity of manure. In a view to increase the manure discharge from the outlets, the number of blades have been decreased to four. It is made up of mild steel sheet of 2 mm thickness with inner and outer diameters as 100 and 200 mm. A circle of 60 mm diameter and four lines passing through the origin making  $90^\circ$  with each other are marked on the plate. Four blades in the form of a rectangle of dimension  $70 \times 50$  mm are welded at corresponding four ends. A hub of 20 mm ID is fixed at the center.



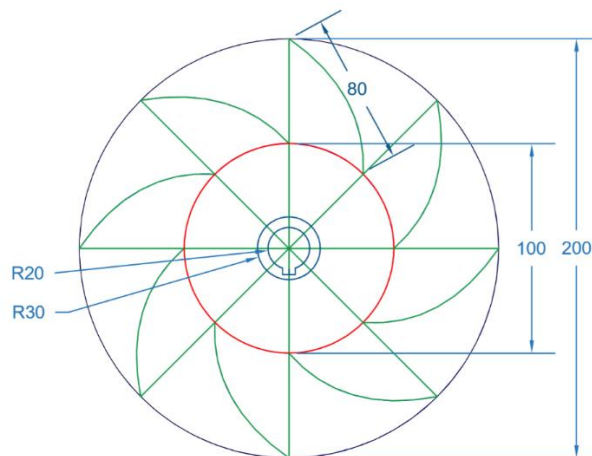
**Fig. 3.11 Elevation view**



**Plate 3.8 Straight 4-blade impeller**

### 3.10.4 Closed radial impeller

In order to achieve larger suction a radial impeller is designed and evaluated. It is made up of mild steel of thickness 2 mm with inner and outer diameters as 100 and 200 mm. A mild steel base plate of 200 mm diameter is marked with lines at  $45^\circ$  with the horizontal as shown in Fig.3.11. Eight blades of dimension  $80 \times 50$  mm in rectangle shape are bent to form a radial arrangement inside the impeller. Diametral pitch is maintained as 7.5 cm and blades are bent at an angle of  $45^\circ$  with axis. GI sheet of 1mm thickness is used to make a thin cover plate over the impeller. A hub of 20 mm ID is fixed at the center.



**Fig. 3.12 Elevation view**



**Plate 3.9 Radial impeller**

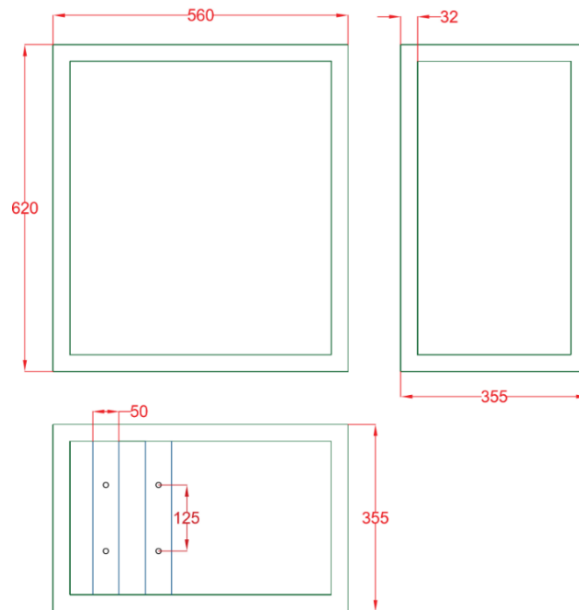
### 3.11 EXPERIMENTAL SETUP

Experimental setup consists of a 3-phase induction motor, variable frequency drive and a blower with impeller rotation in clockwise direction and outlets counted in counter clockwise direction as shown in Fig.3.15.

A VFD regulates the motor rpm by varying the frequency between 1 and 50 Hz where 1 Hz being the lowest rpm and 50 Hz being the highest. The setup is arranged on a stand and evaluated the performance of different impellers with pulverized manure. Frequency readings of the motor such as 30, 40, 50 Hz represent the motor rpm ranging between 890-900, 1190-1200 and 1450-1490 rpm.



To support the complete experimental setup viz., 3-phase induction motor, VFD and blower casing a stand is developed. Mild steel angle flat of dimensions 30×30×2mm is used. A rectangular frame of dimension 620×560×355 mm is made strong enough to support the blower unit. A mild steel flat 50×5 mm is used for cutting two supports of length 300 mm and arranged at one end as shown in Fig. 3.12. Holes are drilled 125 mm apart from center to facilitate the motor.



All dimensions in mm

**Fig. 3.13 Supporting stand for blower**

### 3.11.1 Variable frequency drive(VFD)

A variable frequency drive (VFD) is a type of motor controller that drives an electric motor by varying the frequency and voltage of its power supply. Though the drive controls the frequency and voltage of power supplied to the motor, it is often referred as speed control, since the result is an adjustment of motor speed. VFD is always limited to a 3 phase input current. So a 3 phase 1 hp AC motor that runs at a maximum rpm of 1440 is selected.

The VFD used in the study was of following configuration:

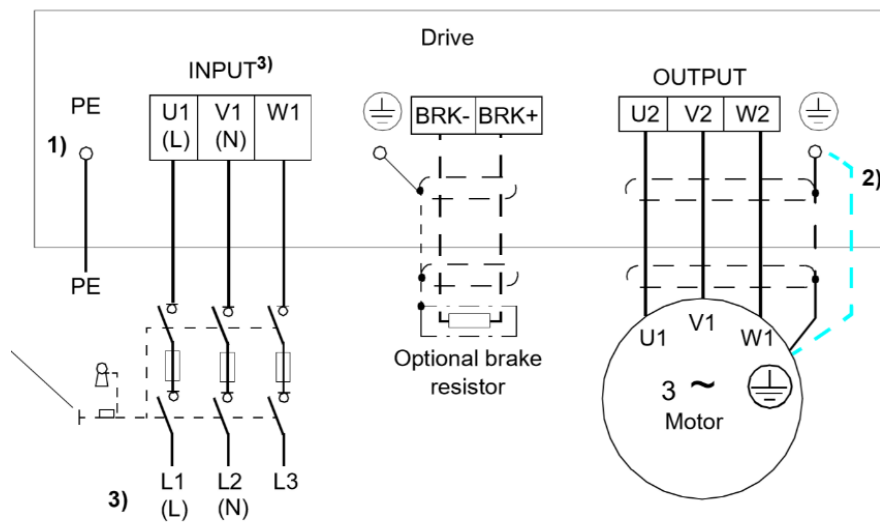
**Make:** ABB

**Rated power:** 0.37-4 Kw

**Voltage:** 380-480 v ac

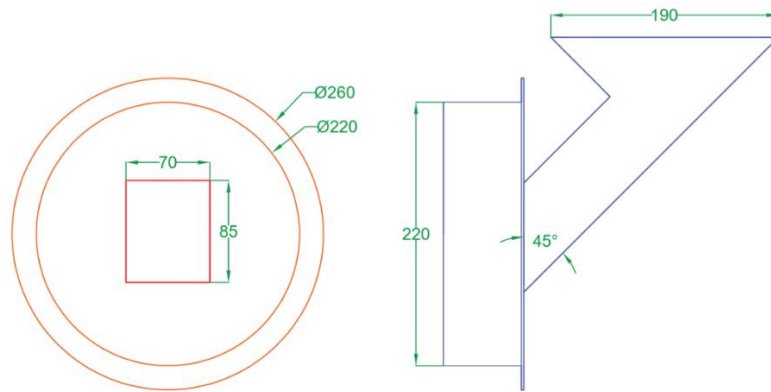
**Current:** 7.3 a

**Weight:** 1.4 kg

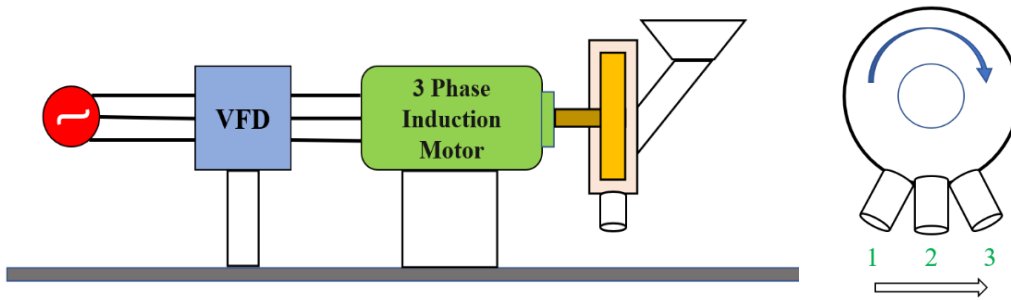


**Fig. 3.14 Circuit connection diagram of VFD and motor**

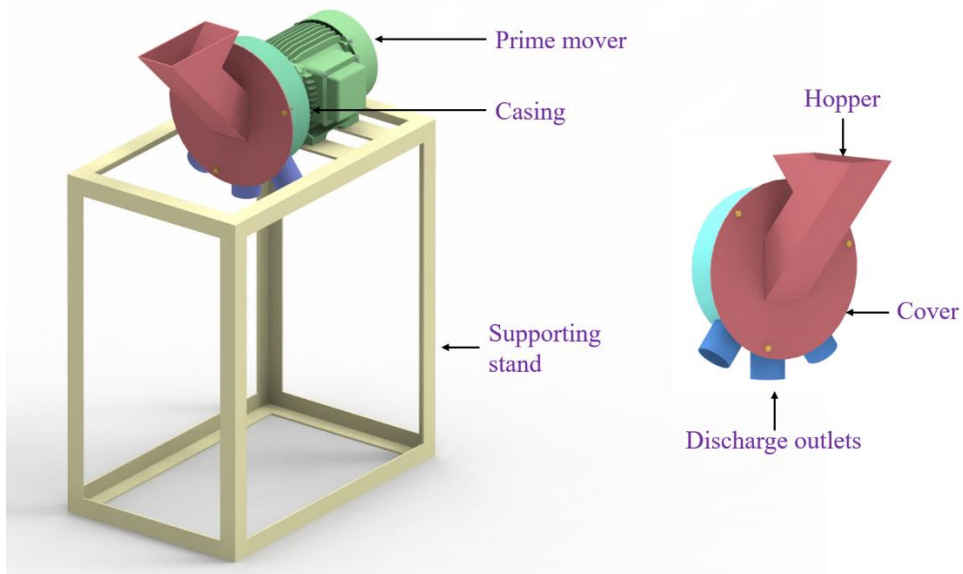
L1,12,13 represent the connection to 3 phase main supply and u1,v1,w1 represent the connections to an AC motor.



**Fig. 3.15 Elevation view of blower casing and hopper**



**Fig. 3.16 Experimental setup of blower working model**



**Fig. 3.17 Blower working model**

### 3.11.2 Assembly of laboratory blower model

While designing the applicator prototype, the manure flow from the pulverizer is anticipated to reach directly above the blower. Hence in the first case, a blower casing with trapezoidal prism feeding hopper was made directly above the blower. A GI sheet of 1.5 mm thick is cut circle to form a back plate of diameter of 220 mm. And same sheet of dimensions 700×60 mm is cut and bent to make a casing around the circumference. A rectangular cut section of 80×60 mm is made at the top of the casing. Trapezoidal hopper of cross section 200×150 mm is made along with a rectangular projection of 80×60×50 mm using a GI sheet of 1.5 mm thickness.



**Plate 3.10 Blower casing**



**Plate 3.11 Difficulty in manure input**

Since blower discharges air throughout its circumference, with the inlet at the top of the blower inputting manure into the blower became difficult due to opposing air from inlet and it resulted in a lot of drift. So the feed inlet is provided with a plate tangentially inclined to reduce the opposing air from inlet. Tangential plate reduced the opposing air but at the same time it reduced the input feed that resulted in a reduced discharge rate.

To overcome the constraints encountered in the above case feeding inlet is provided at the eye of the blower. Providing inlet sideways i.e., at the eye of blower is found beneficial because of the suction at the eye and zero opposing air as seen in the above case. Suction at the eye is used to suck the manure as a result manure is fed to the impeller which is whirled tangentially gaining a high velocity and leaves the outlets.

Hopper at the suction eye is created by making a rectangular cut section of 85×70 mm on the front covering plate. Inlet to this hopper is arranged at 45° angle to face plate as shown in Fig.3.14.



**Plate 3.12 Hopper provided at eye**

### 3.12 DESIGN AND DEVELOPMENT OF A 3-WAY RIGHT ANGLE BEVEL GEARBOX

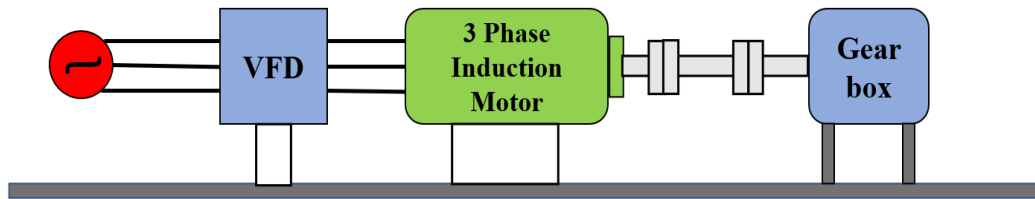
In the present study a 3-way right angle bevel gearbox is designed and developed to achieve different or equal rpms from both the outputs. Although there are a lot of commercially available 3-way right angle gearboxes, they mainly involved gear reduction and the output shafts are opposite to each other. But here in this case a 3-way gearbox with output shafts at right angle to each other are recommended. Hence a laboratory model is worked out first before proceeding for actual gearbox prototype. Here the input power for gearbox is derived from the tractor PTO(540rpm) that is converted into 1000rpm at both outputs (1&2). It consists of 3 spur gears and 2 bevel gears of 1:1 ratio inclined at 90 degree under synchrony-meshed condition.

The experimental setup consist of a 3-phase induction motor, VFD and gear assembly. The gear assembly is directly connected to 3 phase induction motor by a propeller shaft and flange joint. Results from the experimental setup of blower indicate that an impeller input RPM of 800-1000 provided a good clogging free manure dissipation. So an RPM of 1000 is preferred at the output shaft 2. Output shaft 2 is used for impeller rotation in the blower and output shaft 1 is for rotating pulverizer blade connected by means of a pulley.

#### 3.12.1 Development of a laboratory model

A laboratory model was developed to predict the possibility of deriving two variable speeds from a single output. Results obtained from the blower experimental setup show that an rpm of 800-1000 is sufficient for running the blower with an output of 3 kg min<sup>-1</sup> when evaluated with radial impeller. In case of pulverizer unit, results showed that an output of 500 kg h<sup>-1</sup> was obtained when operated at 1440rpm. So right angle bevel gear set up with 1:2 ratio is developed and evaluated as shown in Fig.3.18.

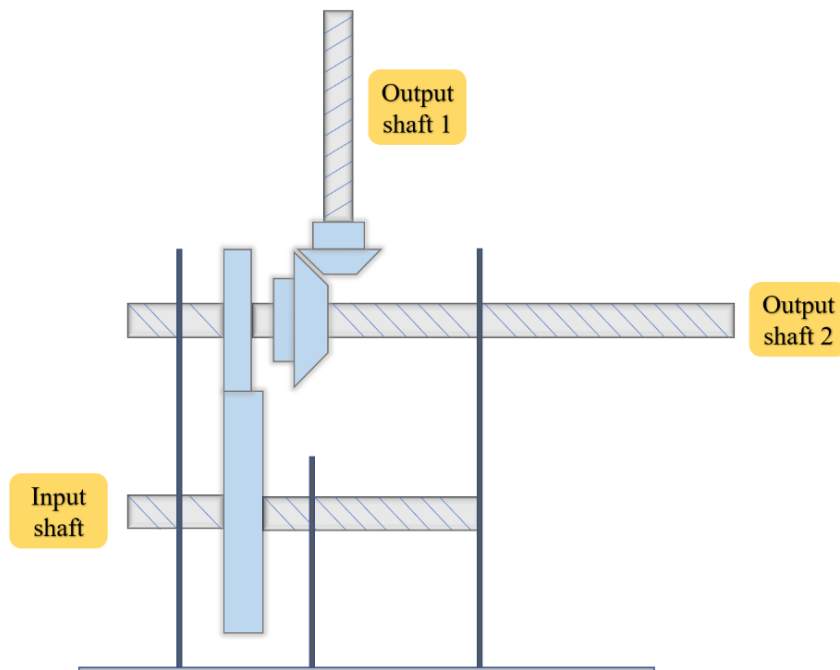
Experimental setup consists of a VFD, 3 phase induction motor and gear assembly setup. Power to the VFD is drawn from a 3-phase power supply which is then connected to 1 HP AC motor. Rotational power to the primary shaft in the gear assembly is taken from the motor shaft connected by means of a hub. By varying the frequency of motor, the performance of the setup was observed.



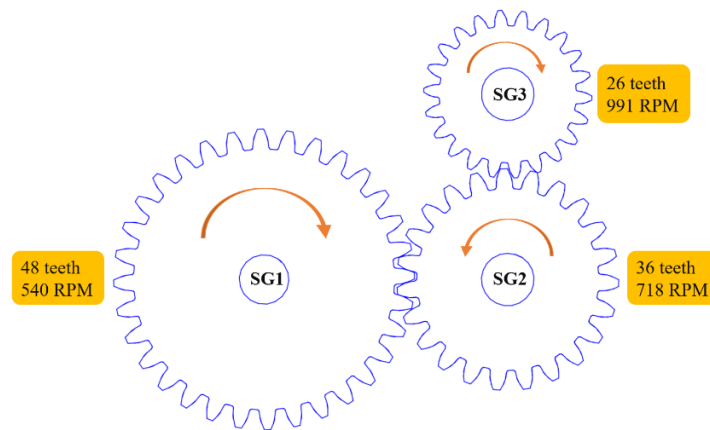
**Fig. 3.18** Various parts of the gearbox experimental setup

### 3.12.1.2 Gear assembly

Gear assembly consist of 3 straight spur gears and 2 right angle bevel gears. In order to increase the input speed from tractor p.t.o, the spur gears are arranged in decreasing order of number of teeth as shown in Fig.3.19. The clockwise rotation of SG1 gets converted into anticlockwise rotation at SG2 so a third gear SG3 is aligned to get clockwise rotation at two output shafts.



**Fig. 3.19** Line diagram of a 3-way right angle bevel gearbox model



**Fig. 3.20 Arrangement of spur gears**

SG1 with 48 teeth is directly connected to input motor shaft running at 540 rpm which is further aligned to SG2 with 36 teeth increasing the gear ratio to 1:1.33. So 540 rpm at SG1 is converted into 718 rpm at SG2. Further SG2 is connected to SG3 with 26 teeth increasing the gear ratio to 1:1.38. The shaft supporting SG3 is also provided with a bevel gear set of 1.6 gear ratio such that two outputs at right angle to each other are obtained. So the rpm is finally increased to 991 rpm at output shafts 2 and 1545 rpm at output shaft 1.



**Plate 3.13 Experimental setup of 3-way right angle gearbox**



Performance of gear assembly model is found to be perfect to carry out both impeller and blade rotation. Instead of using 3 spur gears at the first place, one can choose only 2 with maximum difference in the number of teeth. But it results in anticlockwise rotation of output shafts and more noise and wear due to huge increase in gear ratio. Also, 1:2 incremental gear ratio of bevel gears resulted in more vibration and less strength at the output shaft 1. So it is decided to choose a 1:1 gear ratio that results in achieving equal rpm at both the shafts 1 and 2. Same gears are further used for developing gearbox prototype.

### **3.12.2 Development of gearbox prototype**

#### ***3.12.2.1 Development of casing***

In order to decide the dimensions of gearbox before fabricating the prototype, a graphical model was designed in solid edge software. For safe and satisfactory operation of the gearbox, there is a need to create spacious chamber that can accommodate more lubrication oil. From the model, the dimensions of the box was decided as 300×170×250 mm. A mild steel plate of 12 mm thickness was selected for casing.

Two mild steel plates each of dimension 300×250, 300×170 and 170×226 mm are cut and marked to drill holes for placing ball bearings.



**Plate 3.14 Mild steel plate of 12mm thickness**

### 3.12.2.2 Selection and development of gears

Gear drives also called positive drives are toothed members which transmit power or motion between two shafts by meshing without any slip. In any pair of gears, there is a driver member which is driving the other. When smaller gear is the driver, it results in step down drive in which the output speed decreases and the torque increases. On the other hand, when the larger gear is the driver, it results in step up drive in which the output speed increases and the torque decreases.

Three commercially available spur gears of fixed specification (Fig.3.15) were selected depending on the requirement from the production list and a bevel gear set of 1:1 gear ratio is developed. Spur gears have their teeth parallel to the axis and are used for transmitting power between two parallel shafts. Bevel gears transmit power between two intersecting shafts at any angle or between non- intersecting shafts.

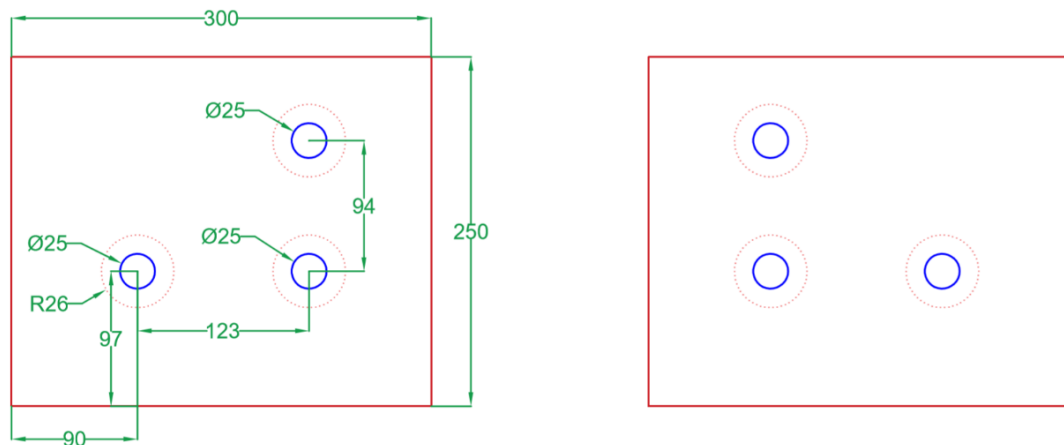
SG1 with 48 teeth is directly connected to input motor shaft running at 540 rpm which is further aligned to SG2 with 36 teeth increasing the gear ratio to 1:1.33. So 540 rpm at SG1 is converted into 718 rpm at SG2. Further SG2 is connected to SG3 with 26 teeth increasing the gear ratio to 1:1.38. The shaft supporting SG3 is also provided with a bevel gear set such that two outputs at right angle to each other are obtained. So the rpm is finally increased to 991 rpm at both output shafts 1 and 2.



**Plate 3.15 Spur gears and bevel gears**

Hole 1,2 and 3 are marked on the plates by considering the center to center distances of selected gears. Pitch circle diameter, root diameter and module of the gears were noted and cross checked for better alignment. SG1, SG2 and SG3 are arranged on a flat surface in designed manner to measure the center to center distances and are

marked on the plates leaving 90 mm from the side. A full bore of 25mm and 7mm depth bore of 52mm diameters are drilled to input p.t.o shaft at hole 1 (since ball bearing OD is 52mm). For the other two shafts only 7mm depth bores of 52mm OD are drilled to accommodate ball bearings. The other plate that comes exactly opposite to the first plate is drilled following the same procedure but in clockwise manner. Edges of the plates are chamfered at 45° angle to form a groove at the joining.



All dimensions in mm

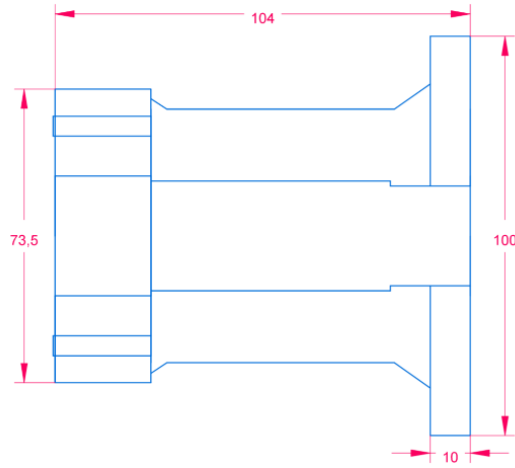
**Fig. 3.21 Elevation view of drilled holes**

### 3.12.2.3 PTO coupling

Input p.t.o shaft undergoes tension, bending and breaking stress during operation. To stabilize the rotation of input shaft and to prevent oil leakage an oil sealed coupling block was developed and welded to gearbox casing. A cylindrical cast iron block was used to develop coupling with dimension as shown in Fig.3.21.

Basic coupling of almost any gearbox consists of enough bore diameter to accommodate input p.t.o shaft, ball bearing and oil sealing. A cylindrical cast iron block of 3 inch dia and 4 inch height is taken. The block is centered and facing was done by using a lathe machine. Centre of the block is drilled with varying drill bit sizes and depths to create steps inside the coupling which restrict the lateral moment of p.t.o shaft. First the entire depth of the block is drilled with 25 mm dia drill bit. Following this a 27.5 mm dia drill was done up to a depth of 85 mm forming a step inside the block. Proceeding this the front 25 mm length of the block is faced to 73.5 mm with a depth

bore of 55 mm diameter. A ball bearing of ID 30 mm and OD 55 mm is placed in 25mm depth bore. The remaining length of the block is cutoff to reach a diameter of 63.5 mm.

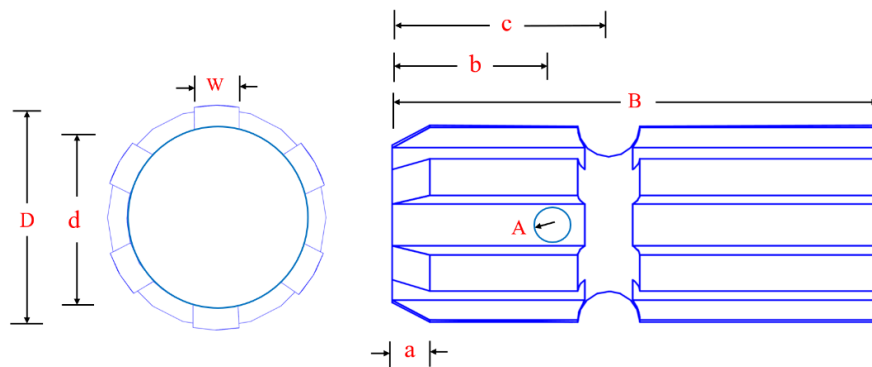


All dimensions in mm

**Fig. 3.22 Elevation view of P.T.O coupling**

#### 3.12.2.4 Shafts

Four shafts viz., p.t.o, stationary shaft, output 1 and 2 shafts are developed. Mild steel rods are used for making shafts. The diameter of the input p.t.o shaft was varied throughout its length of 360mm to facilitate splines, cast iron coupling and ball bearings over the shaft.



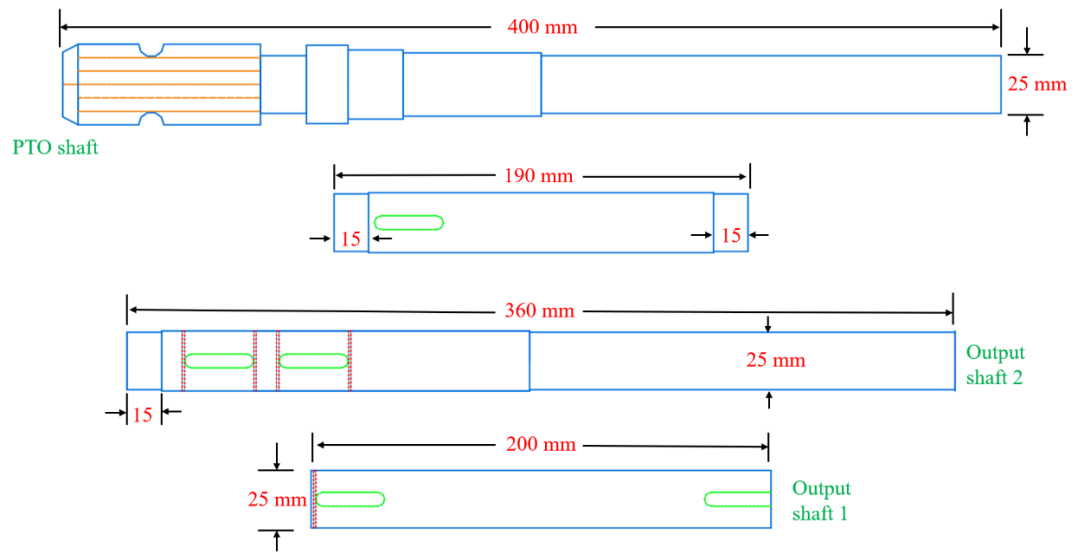
**Fig. 3.23 Elevation view of input P.T.O shaft**

**Table 3.4 Elevation view of developed P.T.O shaft**

Sl. No.	Specification	As per IS: 4931-1995	Developed shaft, mm
1	No. of splines	6	6
2	Input speed (rpm)	540±10	540
3	D	34.79±0.06	34.5
4	d	28.91±0.05-0.15	28
5	W	8.69-(0.09 to 0.16)	7
6	B	76 (min)	86
7	b	25±0.5	26.5
8	c	38	38.5
9	a	7.0	6.63
10	A	8.3 (optional)	7.5

A second stationary shaft of length 190 mm is completely cased inside the gearbox with ball bearings on either side. An output shaft 2 of length 360 mm is in horizontal to the input shaft which is projected outside for running blower. And an output shaft 1 of length 200mm and a uniform diameter of 25mm throughout its length, perpendicular to output shaft 2 connected by means of a bevel gear as shown in Fig.3.24 is developed.

Development of p.t.o shaft follows IS: 4931-1995 standard with 6 splines and nominal speed of 540±10 rpm in clockwise direction.



**Fig. 3.24 Elevation view of shafts**

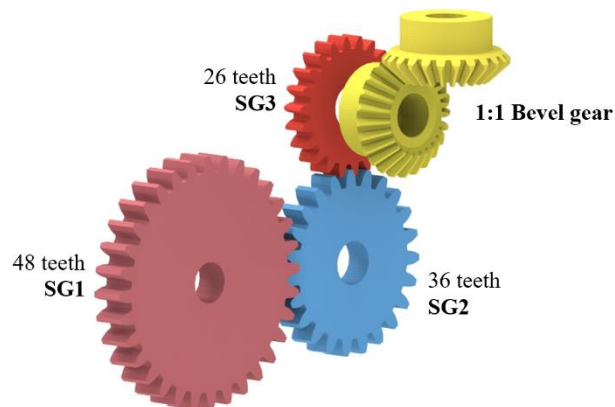


**Plate 3.16 P.T.O shaft and output shafts**

Key slots of dimension 30×6 mm are made on four shafts to maintain stiffness of gears. Sir pins are attached on either side of each gear to prevent lateral movement of gears.

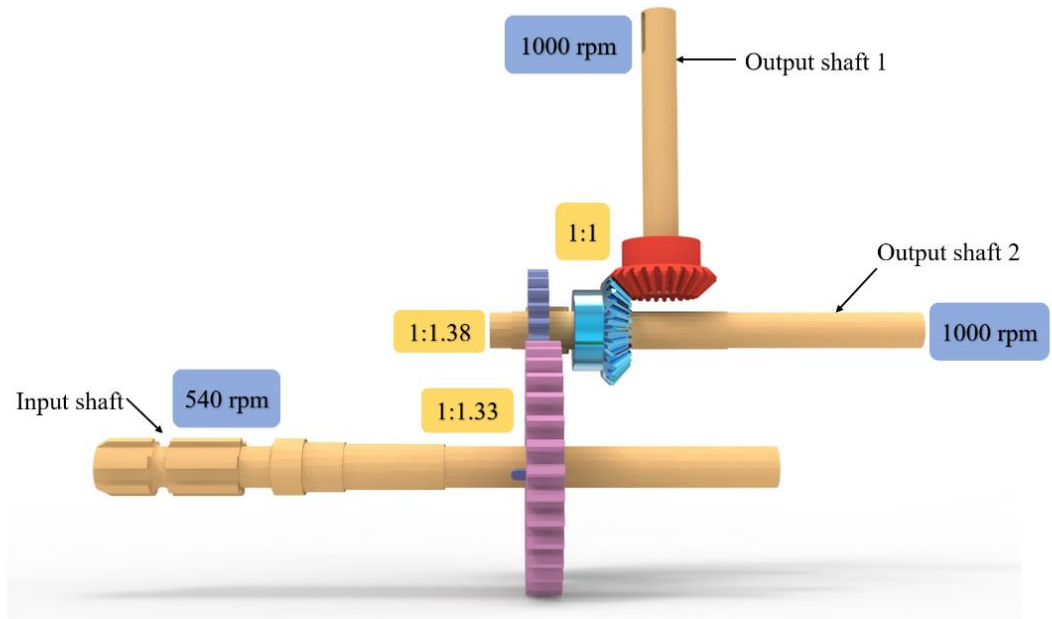
### 3.12.2.5 Assembly

Gearbox casing was welded on all three sides leaving one side open for assembling and further closed by M14 machine bolt. First the p.t.o shaft is enclosed by an oil tight casing, inserted through the input shaft hole and welded directly to the gearbox casing. The spur gears (1,2 & 3) evaluated in the model are directly used in the development of prototype. Spur gear 1 (SG1) is attached to the input shaft locked in key slot between sir pins. Spur gear 2 (SG2) of 36 teeth is aligned to the input shaft which results in an increase in the gear ratio by 1:1.33. Spur gear 2 is mounted on a shaft which acts as an idler completely enclosed in the gearbox without any output shaft. So an input 540 rpm from the tractor p.t.o is increased to 720 rpm at the second shaft but the rotation is in anti-clock wise direction. In order to further increase the rpm and change the direction of rotation, a third spur gear (SG3) is used.

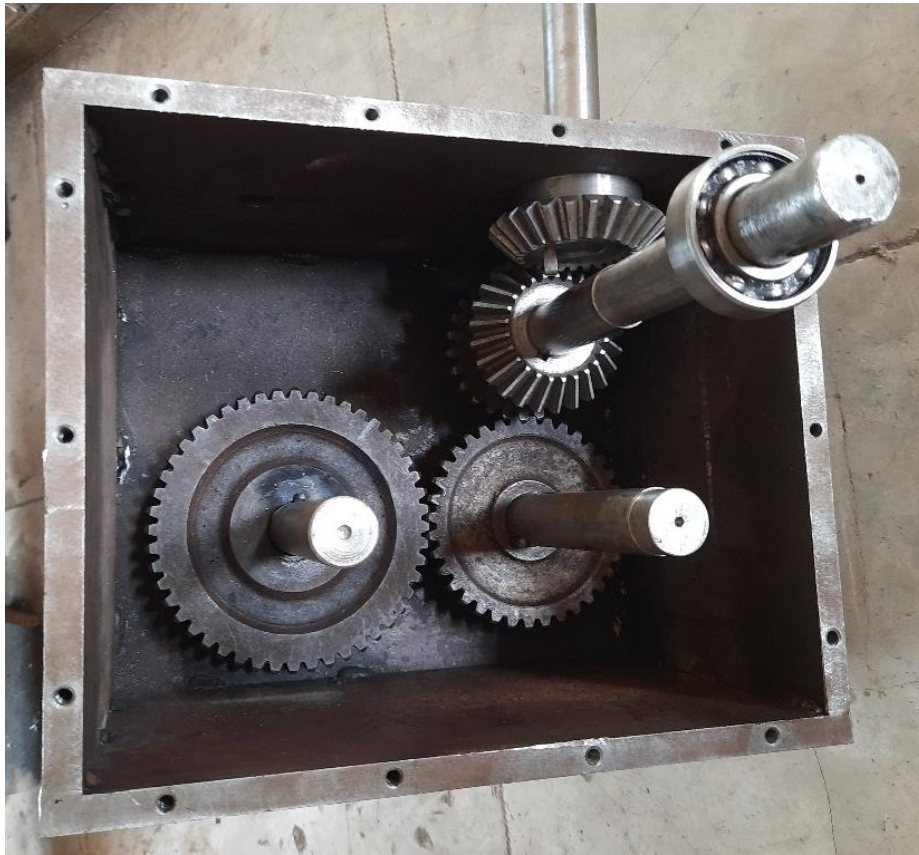


**Fig. 3.25 Arrangement of gears**

Correspondingly, the rotation will be in clock wise direction and rpm at the output shaft 2 becomes 990 with an increase in gear ratio of 1:1.38. The bevel gear setup mounted on the output shaft 2 gives an output at the top of the gearbox which acts as an output shaft 1 to rotate the pulverizer unit. Bevel gears with 1:1 gear ratio are chosen so an rpm of 991 will be noted at both the outputs.



**Fig. 3.26 Gearbox prototype**

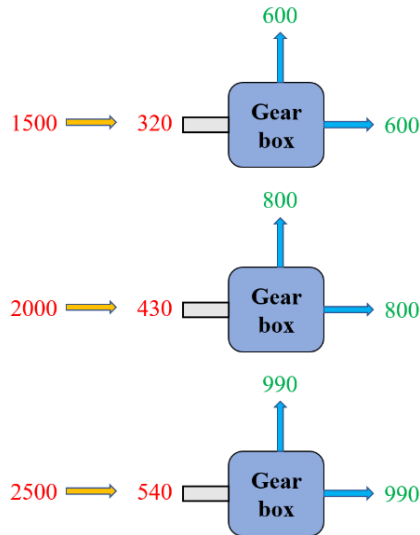


**Plate. 3.17 Assembly of gearbox**



### 3.12.2.6 Variation in gearbox output speeds due to variation in engine rpm

Every minor variation in the input rpm results in the change of output speeds of two shafts. Hence application rate of manure can be varied in the field for selected levels of output blower rpm.



**Fig. 3.27 Variation in gearbox output speeds, RPM**

### 3.13 EXTENSION SHAFT

Drive to the pulverizer unit is taken directly through the extension shaft connected to output shaft 1 of the gearbox. A solid mild steel rod of 720mm length and 32mm diameter is selected. One end of the shaft is connected to the output shaft 1 with a flange coupling and the other end is left for various pulley arrangements.

To avoid tension and bending in the shaft, two block bearings of diameter 1 1/8 inch (28.5mm) are arranged at 270mm apart.

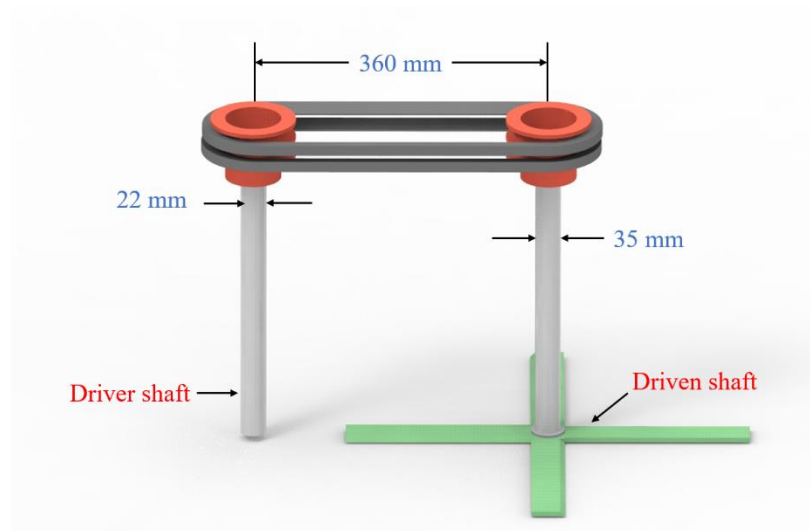


All dimensions in mm

**Fig. 3.28 Line diagram of extension shaft**

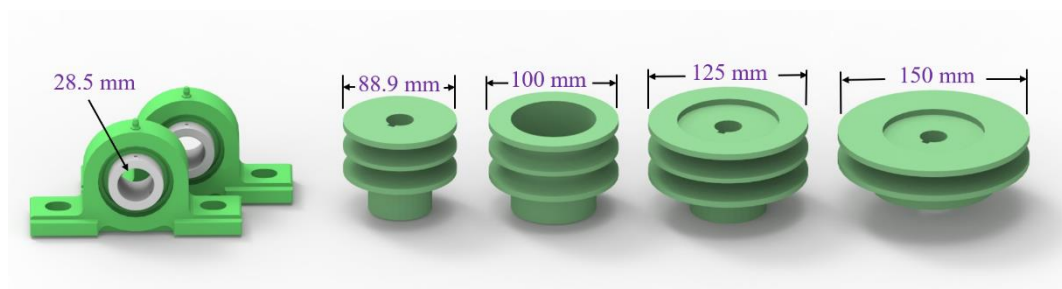
### 3.14 SELECTION OF PULLEYS AND BELTS

Center to center distance between driver and driven pulleys is kept constant as 360mm. By changing the diameter of pulleys at driver and driven end, different combinations of pulley diameters and belt lengths will result in various pulverizer blade rotation speeds. Velocity ratio and belt lengths is calculated keeping a center to center distance of 36cm.



**Fig. 3.29 Arrangement of two double v-belt pulleys**

The pulley at the driven end is kept constant and the driver end is left for various diameter pulleys.



**Fig. 3.30 Selected sizes of block bearings and pulleys**

#### 3.14.1 Velocity ratio

When two pulleys (driving and driven pulley) are connected by a belt so that rotation of one causes the rotation of other, then

$$\pi \times N_1 \times D_1 = \pi \times N_2 \times D_2 \quad (\text{No slippage condition})$$

$$\frac{N_1}{N_2} = \frac{D_2}{D_1} = \text{Velocity ratio}$$

Where,

$N_1$  = RPM of driver pulley

$N_2$  = RPM of driven pulley

$D_1$  = Dia of driver pulley

$D_2$  = Dia of driven pulley

**Table 3.5 Velocity ratio of selected pulleys**

Sl. No.	Driver pulley		Driven pulley	
	D <sub>1</sub> (cm)	N <sub>1</sub> (RPM)	D <sub>2</sub> (cm)	N <sub>2</sub> (RPM)
1	8.89	991	10	881
2	10	991	10	991
3	12.5	991	10	1238
4	15	991	10	1486

### 3.14.2 Length of the belt

By increasing the amount and degree of manure being pulverized per hour the discharge from the applicator can be increased. To increase or decrease the pulverization the rpm of rotating blade should be varied. Four pulleys of different sizes viz., 3½, 4, 5 and 6 inch OD are selected. Performing different combinations of pulleys at driver and driven end will result in varied rpm. Length of the belt is calculated by:

$$L = 2c + \frac{\pi}{2} (D_1 + D_2) + \frac{(D_1 - D_2)^2}{4C} \quad \dots(\text{Sahay., 2006})$$

Where,

L - belt length in inches

C - center to center distance between two pulleys

D<sub>1</sub> - diameter of driver pulley

$D_2$  - diameter of driven pulley

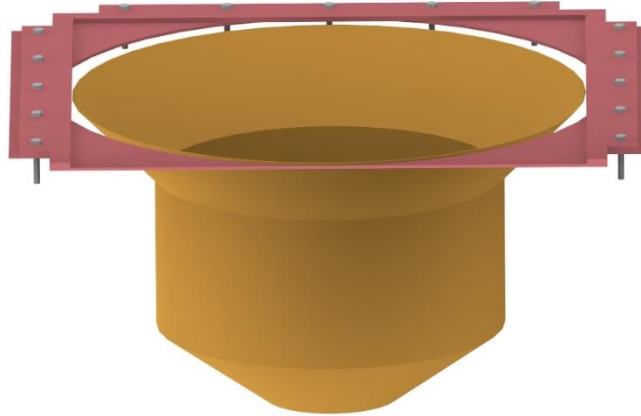
**Table 3.6 Lengths of various belts**

Sl. No.	$D_1$ (cm)	$D_2$ (cm)	Centre to centre spacing (cm)	Length of the belt (inches)
1	8.89	10	36	38
2	10	10	36	39
3	12.5	10	36	40
4	15	10	36	42

### 3.15 CHUTE

Powdered manure from the pulverizer reaches the blower through the chute. Angle of repose of the powdered manure was found to be in the range of 38-42°. A GI sheet of 1.5 mm thick is used to develop the chute. Considering the space available between the pulverizer unit and blower, a chute as in Fig.3.31 is designed and developed.

A chute spacious enough to cover the entire diameter of the pulverizing drum (i.e., 540 mm) is recommended. The initial outer diameter of the chute i.e., 540 mm is gradually decreased to 140 mm at the lower end. The whole chute is developed in 3 stages *viz.*, first cone, cylinder and final cone. The cone immediately below the pulverizer is kept an upper and lower diameters as 540 mm 340mm with a bending angle of 45°. A cylinder immediately below the cone is given a diameter of 340 mm with a height of 150 mm. Finally a cone below the cylinder is developed following the same procedure with upper and lower diameters as 340 mm 130 mm with a bending of 45°. To support the chute a mild steel sheet of 600×580 mm size with 4mm thickness is cut. An opening of 540 mm dia is made on the sheet.



**Fig. 3.31 Chute**

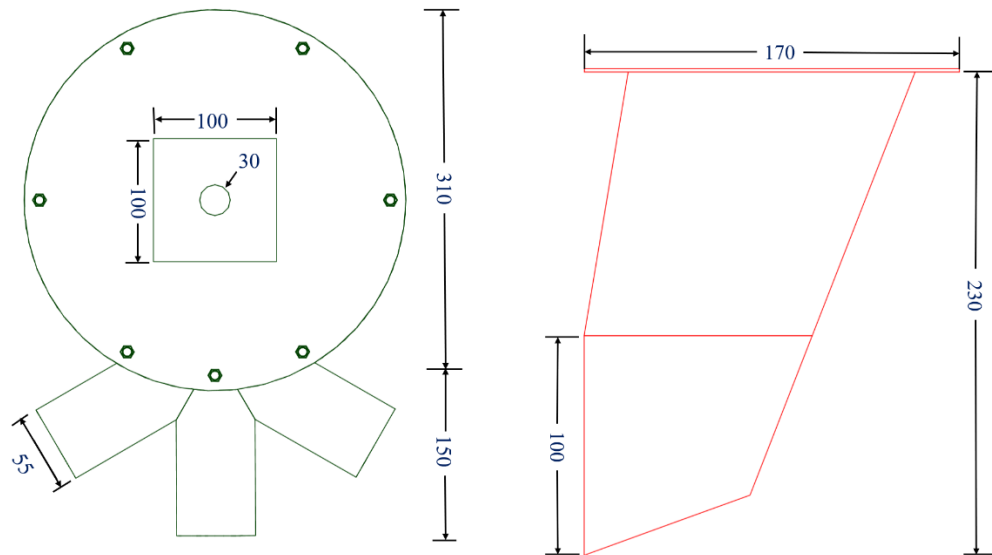
Two semi cones of diameters 540 and 340mm and height 100 mm curved at 45° angle, a cylinder of diameter 340mm and height 150 mm are individually developed and combined together to form the chute. A 170×170 mm square GI sheet is attached at the lower end of the chute with 6 mm bore holes along the length.

### 3.16 DEVELOPMENT OF BLOWER PROTOTYPE

The procedure followed for the development of blower model stated in 3.8, is followed for the design and development of blower prototype. Since input to the blower unit is taken directly from the gearbox, there is a need to provide a rigid blower unit that is capable of overcoming tension and vibration. A mild steel plate of 3 mm thickness is cut to 310 mm diameter to form a back and front cover plate for blower. To provide stability at the corners a 25 mm thick diametral cut piece of 310 mm diameter is welded at both ends. The back and front plates are removable to check for clogging joined by nut and bolt. A GI sheet of 1.5 mm thick is cut to 82 mm length and 65 mm width and bend circularly to fit in between two diametral cut pieces.

One side of the blower is cut open to provide an inlet for blower. A 100×100 mm square opening is provided at the face of the blower as shown in Fig.3.32. The cut face is joined with an inlet hopper to join the blower unit with chute from the pulverizer unit. A GI sheet is used to develop the inlet hopper. The hopper is made such that it fits perfectly in the gap between chute and blower unit. Outlet diameter of the chute is 140 mm such that opening to the inlet is provided large enough to prevent blockage. A

170×170 mm square GI sheet is attached at the outer end of the inlet hopper. A 6 mm 1 inch nut and bolt connection is provided to the inlet making it an individual unit from blower and chute.

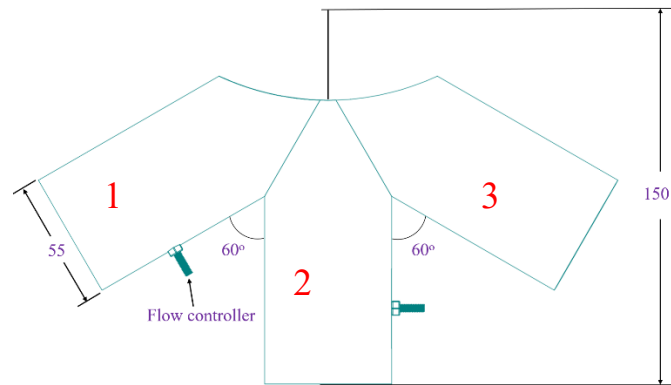


All dimensions in mm

**Fig. 3.32 Elevation view of blower casing and inlet**

In case of the laboratory blower model, outlets are provided individually at certain spacing over the casing. Variation in the outlets is calibrated by changing the input rpm and creating obstruction at the outlet by giving lesser discharge variation. But in the field conditions an outlet discharge controller is needed.

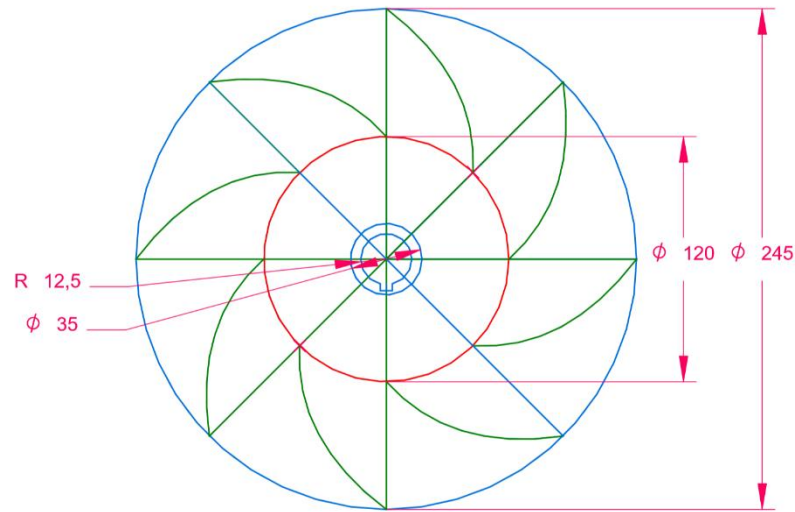
A mild round steel pipe of 55 mm ID is cut to 3 pieces of 150 mm length each. Instead of making three individual outlets on the blower circumference, a single large outlet in an ellipse shape is provided from which three outlets are drawn as shown in Fig.3.33. A single large discharge outlet is then split into three by a special type of outlet pipe arrangement as shown in Fig.3.33. The 3 pipes are arranged at  $60^\circ$  angle with each other from a common point. The overlapping parts are marked and cut to form a single opening matching the outlet on the casing. To regulate the discharge in case of variation, flow controllers are provided at 1<sup>st</sup> and 2<sup>nd</sup> outlets (counted in anti-clock wise direction). Flow controllers are nothing but a semi circular cut section of pipe sliding inside the outlets. a nut and bolt is provided to slide the cut section and tightening it in the outlet.



All dimensions in mm

**Fig. 3.33 Outlets with discharge controllers**

In the laboratory blower model, closed radial impeller showed a good suction and discharge. A radial impeller at 1000 rpm with suction and discharge of  $4.3 \text{ m s}^{-1}$  and  $2.7 \text{ kg min}^{-1}$  showed the best results compared to other impellers. Hence a radial impeller is preferred over other impellers in the development and evaluation of blower prototype. It is made up of mild steel of thickness 2 mm with inner and outer diameters as 120 and 245 mm. A mild steel base plate of 245 mm diameter is marked with lines at  $45^\circ$  with the horizontal as shown in Fig.3.34. Eight blades of dimension  $85 \times 50 \text{ mm}$  in rectangle shape are bent to form a radial arrangement inside the impeller. Diametral pitch is maintained as 7.5 cm and blades are bent at an angle of  $45^\circ$  with axis. GI sheet of 1.5 mm thickness is used to make a thin cover plate over the impeller. A hub of 25 mm ID with a key way is fixed at the center of the impeller.



All dimensions in mm

**Fig. 3.34 Elevation view of closed radial blade impeller**

### 3.17 ASSEMBLY OF MANURE PULVERIZER CUM APPLICATOR

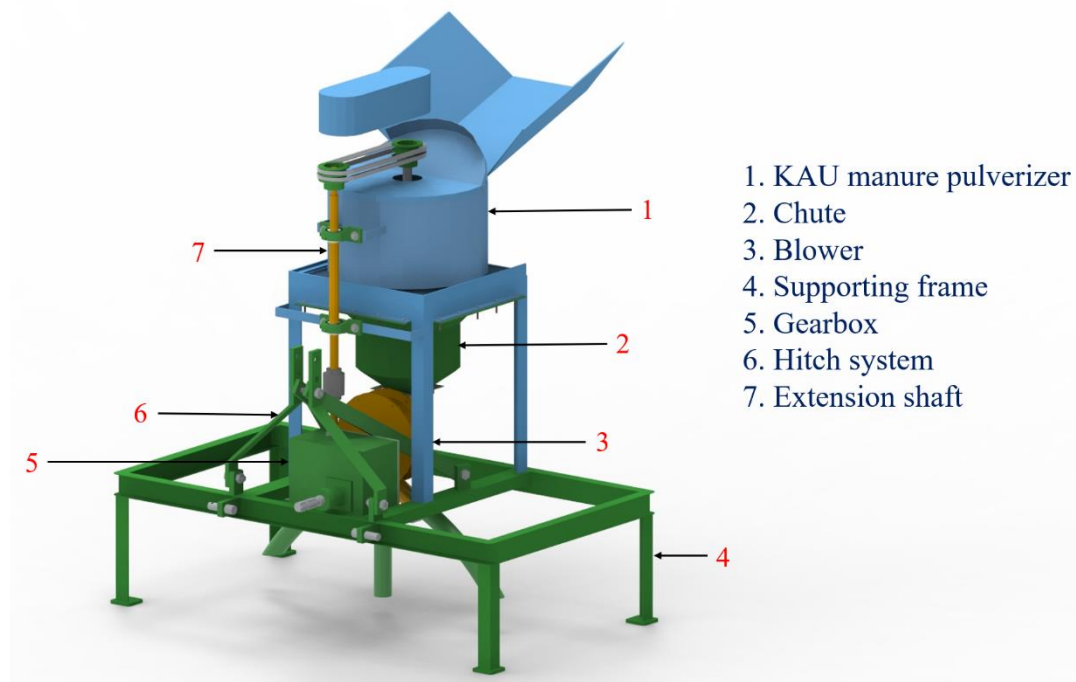
The developed parts viz., KAU manure pulverizer, feed chute, blower, frame&hitch, gearbox and extension shaft are assembled to form a tractor powered manure pulverizer cum applicator. The supporting frame is made large enough to accommodate all the supporting parts.

KAU manure pulverizer is fixed on the supporting frame with nut and bolt making it a removable part. Due to the open spaces left over the outer surface of the pulverizing drum, pulverized manure interacted with air and forms as smoke which is negative impact on the labour.

**Table 3.7 Effect of drift on pulverizer**

Type of manure	Input weight(gm)	Output weight(gm)
Cow dung	500	485.2
Goat faecal pellets	500	472.4
Neem cake	500	477.7

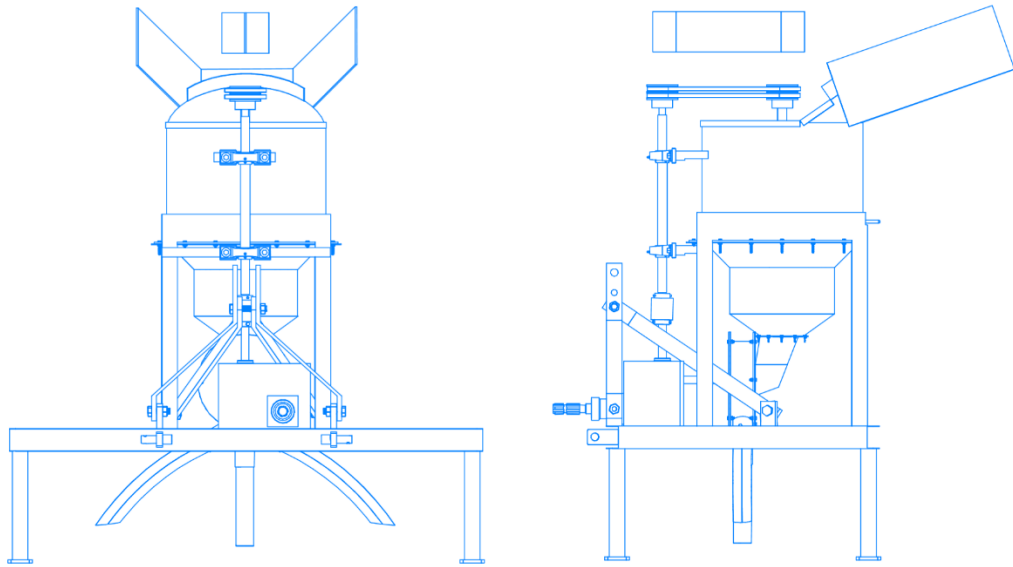




**Fig. 3.35 Manure pulverizer cum applicator**

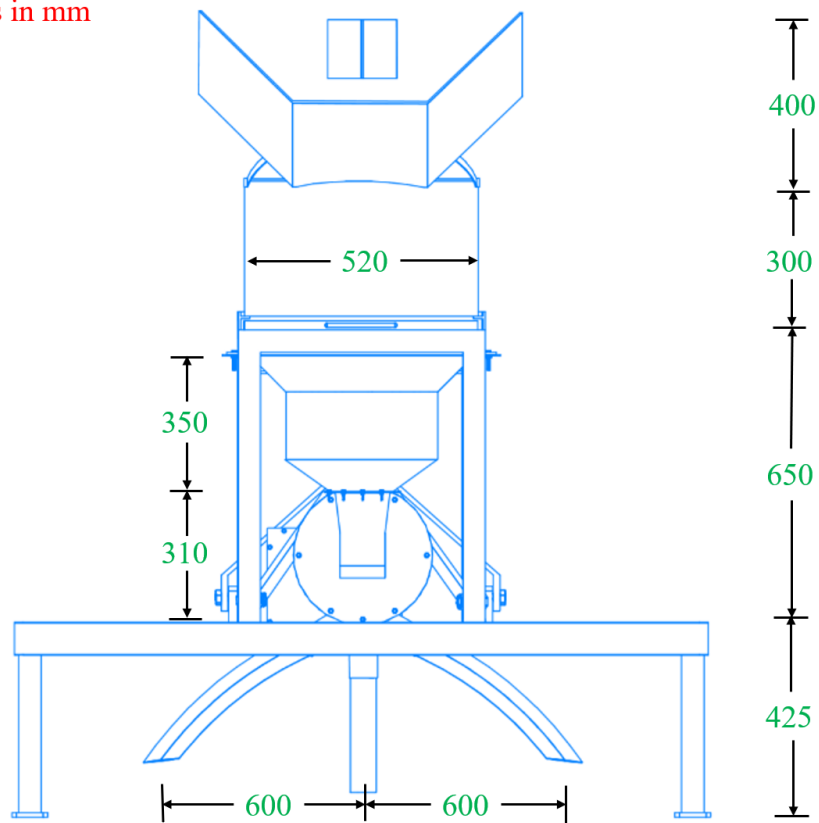
A GI sheet of 1.5mm thick is used to block the manure from the clearance. Pulverizer is made air tight to prevent the losses due to drift. A chute with a supporting frame is attached below the pulverizer with nut and bolt arrangement along the outer surface. To keep the output shafts in-line with blower unit, the gearbox is fixed at certain offset in between upper and lower links. Between the two supporting C-channels in the frame, a L-angle cut section is welded at 195 mm distance to provide enough space and stability to gearbox. Gearbox is fixed rigidly in offset such that both the output shafts are free to propel.

The blower along with input hopper is arranged between the gearbox and chute. Blower is rigidly fixed to the supporting frame with nut and bolt to the mild steel flats welded on either side of the frame. To prevent any clearance between the chute and inlet hopper a square 170×170 mm GI frame was already arranged on inlet hopper and chute with a nut and bolt arrangement making it air tight. An extension shaft of 720 mm length is fixed at the gearbox output shaft by means of a flange coupling with two block bearings placed apart from one another.



**Fig. 3.36 Front and side view of developed unit**

Dimensions in mm



**Fig. 3.37 Elevation view of the developed unit**



**Plate 3.18 Tractor powered manure pulverizer cum applicator**

### 3.18 LOCATION OF STUDY

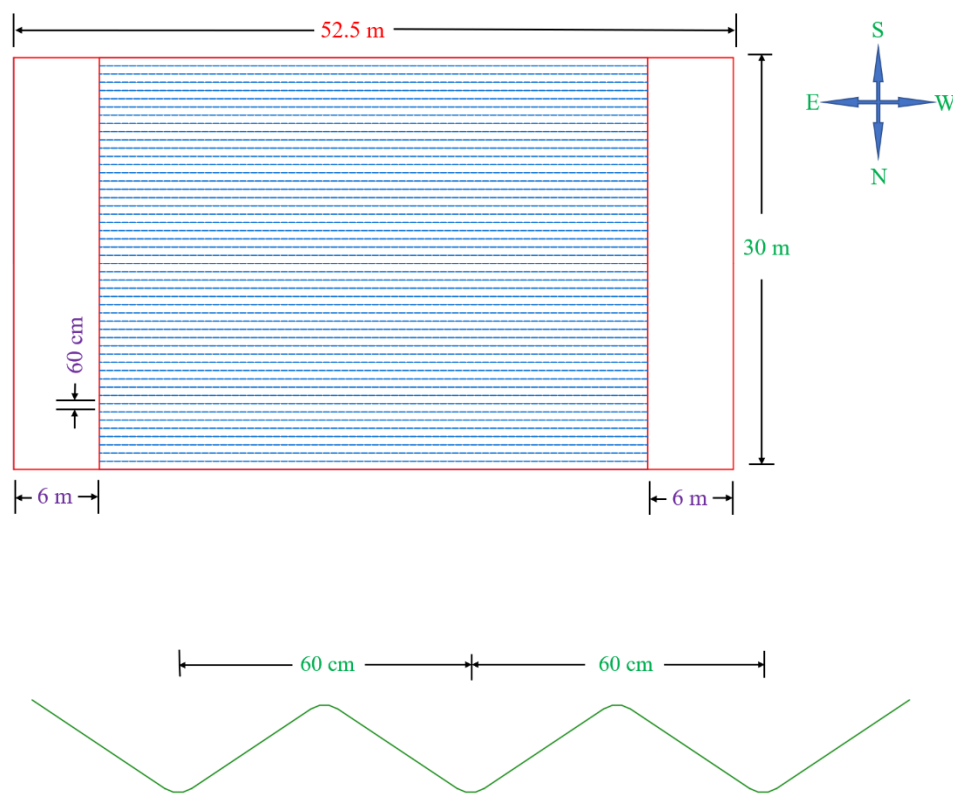
An area of 39.3 cent (0.159 ha) in " block of instructional farm, KCAET, Tavanur was selected for the present study. The areas were situated respectively at 10.8549 N latitude and 75.9879 E longitude.

#### Land use pattern

The tillage practices followed in the experimental plot were leveller and 3 row bund former. Entire plot was completely levelled and continuous bunds of 40 m length with 600 mm spacing were formed.

#### Plot selection and layout

A selected area of 39.4 cent (0.159 ha) was divided into a 30×40 m<sup>2</sup> (30 cent) plot leaving 6 m on either side as a head land. The experimental layout of the field was shown in Fig.3.38.



**Fig. 3.38 Layout of experimental field**

### 3.19 Field preparation



**Plate 3.19 Levelling of experimental field**



**Plate 3.20 Rows formation**



**Plate 3.21 Field evaluation of developed unit**

## RESULTS AND DISCUSSION

## CHAPTER IV

### RESULTS AND DISCUSSION

The study was undertaken to develop and test the tractor powered manure pulverizer cum applicator for cow dung, goat faecal pellets and neem cake application at desired spacing. This chapter deals with the results of physical properties of manure, performance evaluation of the developed machine in laboratory and field, and its cost economics are also carried out. To ensure good quality of the manure, bulk density, moisture content, angle of repose and coefficient of friction were evaluated. Machine parameters *viz.*, PTO speed, blower speed, air flow rate and size of valve opening were selected as the major factors influencing the performance of the machine.

Performance parameters *viz.*, field capacity, field efficiency, discharge rate, degree of pulverization, coefficient of uniformity, swath width and fuel consumption were evaluated to ensure an effective performance of the machine in the field.

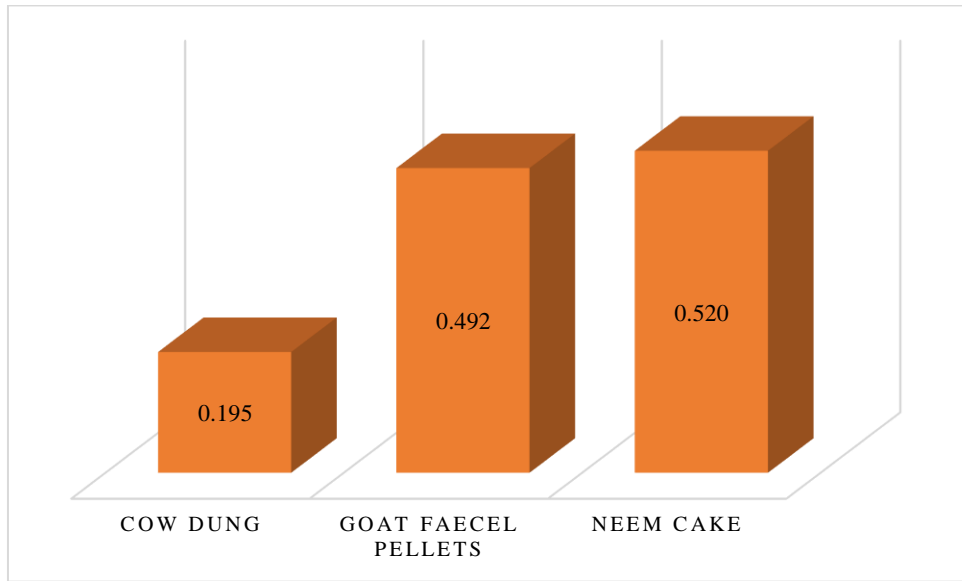
#### 4.1 PHYSICAL PROPERTIES OF MANURE

Cow dung, goat faecal pellets and neem cake were selected as the raw materials for the testing of manure pulverizer cum applicator. The physical properties of manure such as bulk density, moisture content, angle of repose, coefficient of friction and degree of pulverizer which influenced the performance of the manure pulveriser cum applicator were determined.

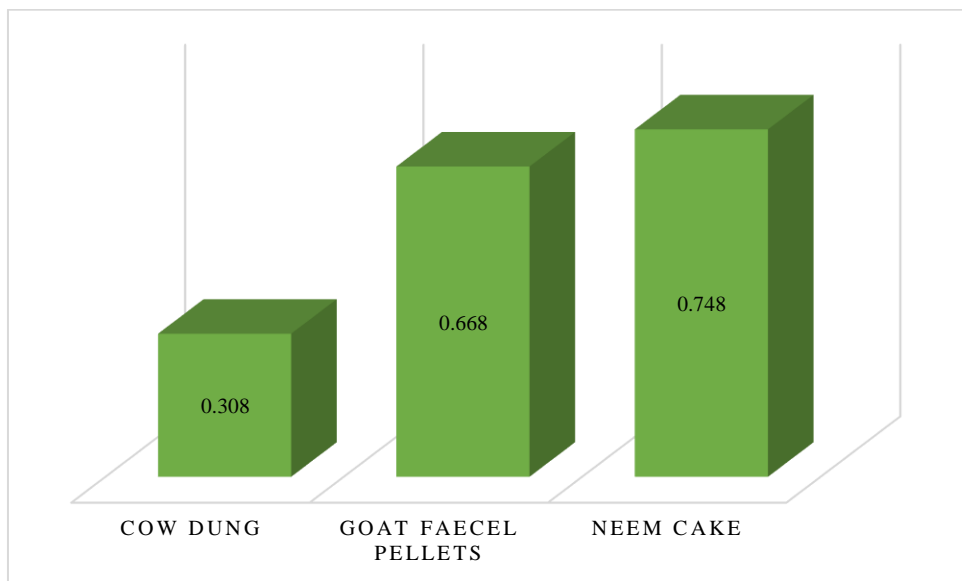
##### 4.1.1 Bulk density

Bulk density of manure was determined as explained in Section 3.2.1 and was found to be  $0.195 \pm 0.01 \text{ g cm}^{-3}$  for cow dung,  $0.492 \pm 0.01 \text{ g cm}^{-3}$  for goat faecal pellets,  $0.520 \pm 0.01 \text{ g cm}^{-3}$  for neem cake.

Bulk density of cow dung was found to be very less compared to goat faecal pellets and neem cake. For a given volume of cylinder, less weight of the manure occupies more volume resulting in a lesser bulk density. Also it effects the application rate of manure for a given time period.



**Fig.4.1 Bulk densities (mean) of manures viz., cow dung, goat faecal pellets and neem cake**



**Fig. 4.2 Tapped densities (mean) of manures viz., cow dung, goat faecal pellets and neem cake**

Manure becomes dense inside the chute because of the continuous deposition of manure. Hence tapped density was determined as a measure of dense nature of manure. Tapped density of manure was determined as explained in Section 3.2.2 and is found to be  $0.308 \pm 0.01 \text{ g cm}^{-3}$  for cow dung,  $0.668 \pm 0.01 \text{ g cm}^{-3}$  for goat faecal pellets,  $0.748 \pm 0.01 \text{ g cm}^{-3}$  for neem cake.



#### **4.1.2 Moisture content**

The moisture content of manures *viz.*, cow dung, goat faecal pellets and neem cake were calculated by oven dry method as explained in the Section 3.2.3, and were statistically analyzed and shown in Appendix II. Increase in the moisture content of manure causes decrease in the efficiency due to adhesion nature of manure. When moisture content of manures exceeds 25 %, wet lumps are formed affecting the pulverizer capacity. Cohesive nature of manure turns into adhering nature and sticks to side walls of pulverizer drum due to rotation of pulverizing blade.

The average values of moisture content are found out as 19.04% for cow dung, 19.04% for goat faecal pellets and 21.03% for neem cake respectively.

#### **4.1.3 Angle of repose**

Angle of repose plays an important role in design and development of hoppers and chutes and has considerable effect on the sliding of the manure. Pulverized cow dung gets accumulated in the hopper since it occupies more volume with less weight, Whereas goat faecal pellets and neem cake gets dissipated as quickly as possible because of its less volume to weight ratio. Angle of repose was found out to be  $43\pm 0.1$  for cow dung,  $37\pm 0.1$  for goat faecal pellets and  $38\pm 0.1$  for neem cake. Since the pulverized mixture was finer, angle of repose increased with the decrease in particle size of powder.

#### **4.1.4 Coefficient of friction**

The coefficient of friction of pulverized manure (*viz.*, cow dung, goat faecal pellets and neem cake) for GI sheet, mild steel and aluminum was determined as explained in Section 3. and results were presented in table 4.2. GI sheet was selected considering strength, cost and fabrication easiness compared with other metals.

**Table 4.1. Coefficient of friction of pulverized manure**

Sl. No.	Material surface	Cow dung	Goat faecel pellets	Neem cake
		Mean $\pm$ SD		
1	GI sheet	0.478 $\pm$ 0.01	0.458 $\pm$ 0.02	0.453 $\pm$ 0.01
2	Mild steel	0.525 $\pm$ 0.02	0.502 $\pm$ 0.01	0.494 $\pm$ 0.01
3	Aluminum	0.540 $\pm$ 0.01	0.546 $\pm$ 0.01	0.552 $\pm$ 0.02

#### 4.1.5 Degree of pulverization

Degree of pulverization or fineness of manure was determined by sieve analysis as explained in Section 3.3.5 and obtained data are given in Appendix III (A,B,C). Particle size distribution curves of manures indicate the fineness of manure at respective sieve sizes. Fineness of the manure increased with increasing rpm of the blade and has a little effect on discharge.

#### 4.2 DESIGN AND DEVELOPMENT OF A LABORATORY BLOWER MODEL

In handling the powdered manure through a blower, air was used as a carrier for dissipation. Pulverized manure is a mixture of fine dust particles which have a very less terminal velocity and settling time. Performance parameters *viz.*, suction velocity, air velocities, discharge rate and coefficient of variation were evaluated.

Experimental setup consisted of a 3-phase induction motor, VFD and a blower with impeller rotation in clockwise direction and outlets counted in counter clockwise direction. A VFD regulated the motor rpm by varying the frequency between 1 and 50 Hz where 1 Hz being the lowest rpm and 50 Hz being the highest. The setup was arranged on a stand and evaluated the performance of different impellers with pulverized manure. Frequency readings of the motor such as 30, 40, 50 Hz represent the motor rpm ranging between 890-900, 1190-1200 and 1450-1490 rpm.

As described in materials and methods 3.10.2, initial design of the blower laboratory model consisted of a hopper directly above the blower. While designing the applicator prototype, the manure flow from the pulverizer was anticipated to reach

directly above the blower. Since blower discharges air throughout its circumference, inputting manure into the blower became difficult due to opposing air from inlet and it resulted in a lot of drift. Hence providing at the eye of blower was found to be beneficial because of the suction at the eye and zero opposing air.

Various types of impellers were developed following theoretical design standards under standard ASME codes. To overcome the constraints in one design, errors from their performance were noted and corrected while developing other impellers such that performances of all the impellers were compared to depict the best performance of an impeller for further prototype development.

#### **4.2.1 Variation in suction velocities with impeller RPM**

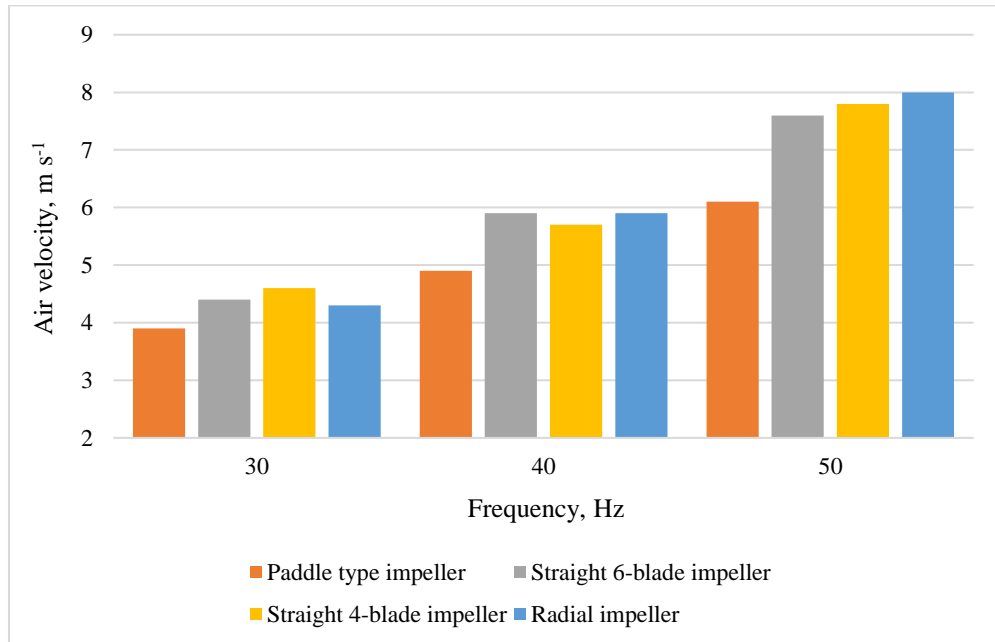
When provided with the paddle type impeller, suction at the eye was very less. Design constraints like more number of blades, very less space provided between face of impeller and covering plate restricted the suction velocity. As a result it effected the discharge of manure. Suction velocities with paddle type impeller were found out as  $3.9 \text{ m s}^{-1}$  at 30 Hz,  $4.9 \text{ m s}^{-1}$  at 40 Hz and  $6.1 \text{ m s}^{-1}$  at 50 Hz respectively.

In case of straight 6-blade impeller with flat blades, suction at the eye was good enough to create a -ve pressure that suck the manure and discharge it through the outlets at high velocity. Also 6 flat blades provided enough space to incorporate manure in between them and whirling action dissipates the manure through outlets. Suction velocities with straight 6-blade impeller were found out as  $4.4 \text{ m s}^{-1}$  at 30 Hz,  $5.9 \text{ m s}^{-1}$  at 40 Hz and  $7.6 \text{ m s}^{-1}$  at 50 Hz respectively. Further no. of blades were reduced to four with a view to increase the suction and provide more space for manure deposition.

In case of straight 4-blade impeller, suction at the eye was good enough to suck the manure and dissipate it through the outlets at high velocity. Four blades provided at  $90^\circ$  angle to each other allows us to incorporate maximum manure in between the blades. Suction velocities with straight 4-blade impeller were found out as  $4.6 \text{ m s}^{-1}$  at 30 Hz,  $5.7 \text{ m s}^{-1}$  at 40 Hz and  $7.8 \text{ m s}^{-1}$  at 50 Hz respectively.

A closed radial impeller with 8 curved vanes similar to a centrifugal fan is developed. Suction at maximum input rpm was high compared to other impellers which resulted in greater suction of manure. Suction velocities with radial impeller were found

out as  $4.3 \text{ m s}^{-1}$  at 30 Hz,  $5.9 \text{ m s}^{-1}$  at 40 Hz and  $8.0 \text{ m s}^{-1}$  at 50 Hz respectively. Backward curved blades in between the plates increased the -ve pressure when the direction of rotation was in clockwise direction.



**Fig. 4.3 Variation in suction velocity with impeller RPM**

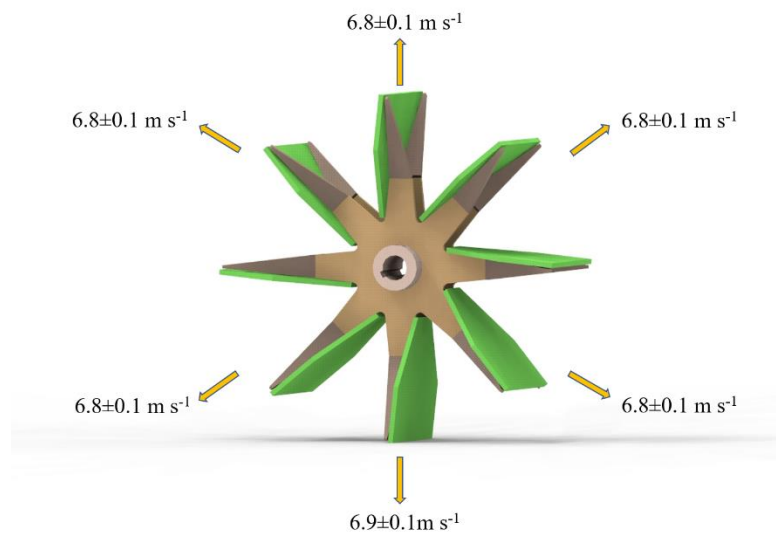
#### 4.2.2 Variation of air velocity with impeller RPM

Air velocity inside the blower and at the outlets decides the path of manure. Pulverized manure is little coarse and fine in nature which is easily sucked, lifted and thrown from the outlets. Although a smaller rpm of the blower can be preferred for dissipating manure, there are cases where manure gets stuck in gap left between blower casing and impeller. So variation of air velocity with impeller rpm along with manure dissipation was noted as shown in Appendix V.

As the RPM of the motor is increased, the air velocity at the outlets increases. Air velocity at each individual outlet has to be same so that manure discharge from each outlet will be same. Variation of air velocity in outlets at 30 Hz is comparatively less than that at 40 and 50 Hz. Impeller with less variation in air velocities was considered to suit the purpose. Direction of rotation of the prime mover was kept in clockwise direction and its speed was varied by using a VFD. Anemometer was used to measure the air velocity along the circumference and at the outlets of the impellers. The graphs

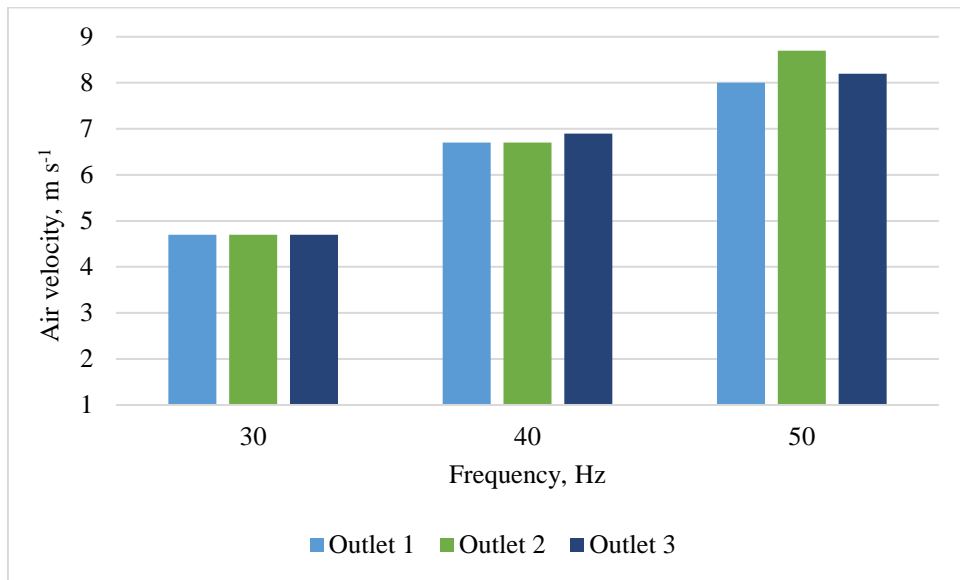
showed the variation in air velocity at each individual outlet w.r.to difference in the RPM at 30, 40 and 50 Hz as shown in Fig.4.5.

In case of paddle type impeller, variation in air velocity along the circumference is very less ranging between  $6.8$  to  $6.9 \pm 0.1 \text{ m s}^{-1}$ . Since impeller is kept open without any casing, a little vibration in experimental setup was noted when rpm exceeded 40 Hz frequency. So measurement of air velocity along the circumference was limited to 40 Hz with varying impellers.



**Fig. 4.4 Air velocity along the circumference of paddle type impeller (40 Hz)**

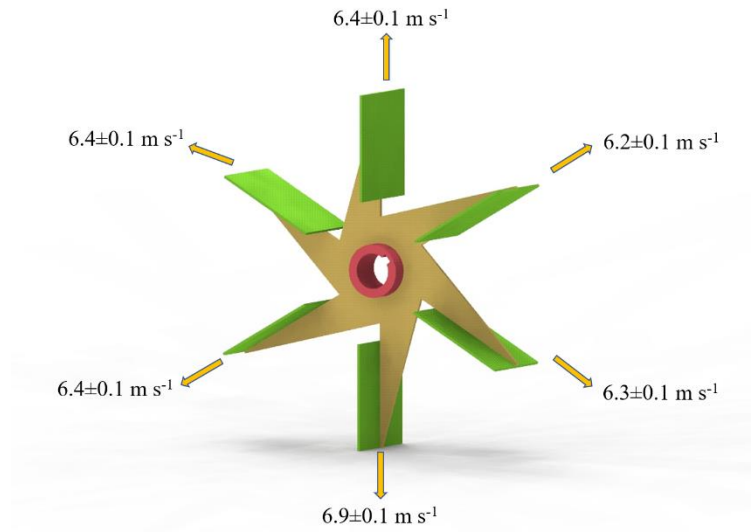
At 30 Hz, air velocity at the individual outlets was same and the variation in air velocity increased with increase in impeller rpm. At 50 Hz, air velocity at the outlet which is directly below the impeller received more air velocity compared to other two outlets. Average of air velocity at the outlets was found as  $4.7 \text{ m s}^{-1}$  at 30 Hz,  $6.8 \text{ m s}^{-1}$  at 40 Hz and  $8.3 \text{ m s}^{-1}$  at 50 Hz respectively.



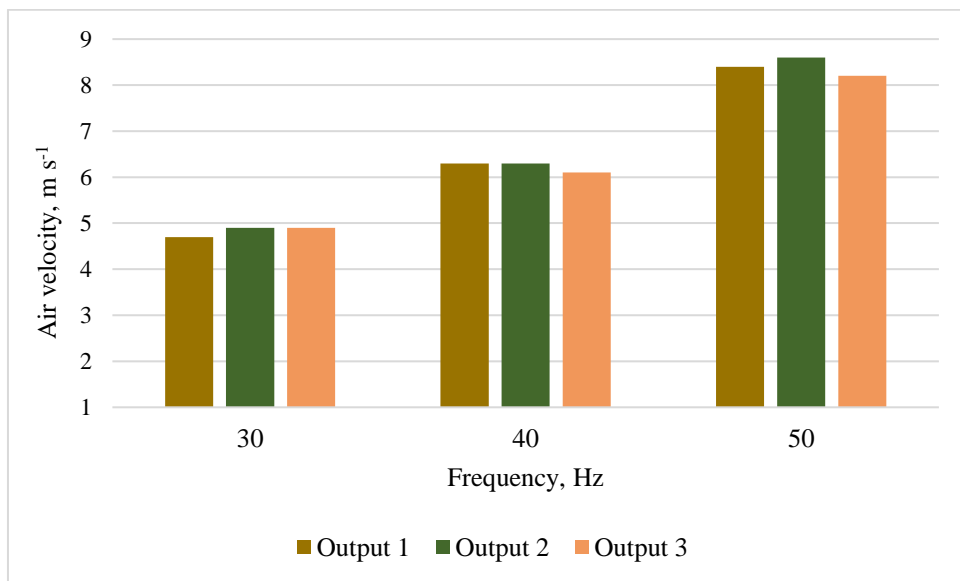
**Fig. 4.5 Variation of air velocity in case of paddle type impeller**

In case of straight 6-blade impeller, variation in air velocity along the circumference was comparatively more ranging between 6.2 to 6.9±0.1 m s<sup>-1</sup>. Air velocity along the circumference was limited to 40 Hz due to vibration and forward motion of experimental setup. Compared to paddle type impeller, air velocity was less because of the reduction in number of blades and at the point directly below the impeller air velocity was comparatively more as shown in Fig.4.6.

At 30 Hz, variation in air velocity at the individual outlets is comparatively less and the variation in air velocity increased with increase in impeller rpm to a smaller extent. At 50 Hz, variation in air velocity at the outlets was less but noticeable. Average of air velocity at the outlets was found as 4.8 m s<sup>-1</sup> at 30 Hz, 6.2 m s<sup>-1</sup> at 40 Hz and 8.4 m s<sup>-1</sup> at 50 Hz respectively.

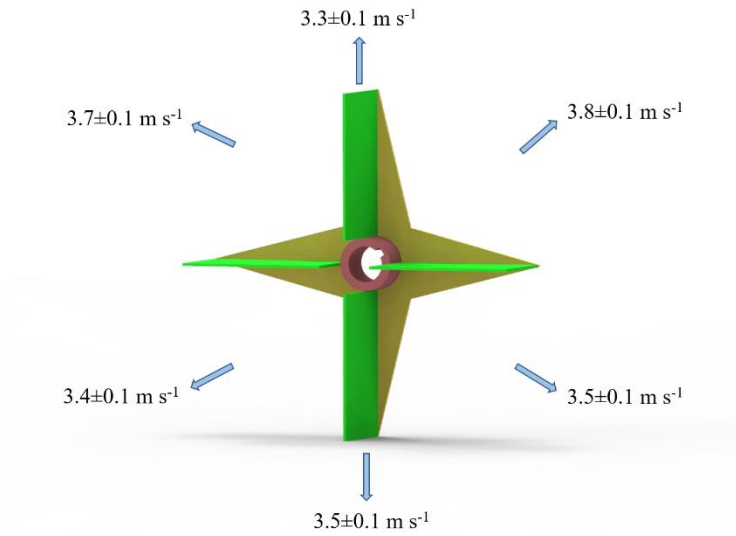


**Fig. 4.6 Air velocity along the circumference of straight 6-blade impeller (40 Hz)**

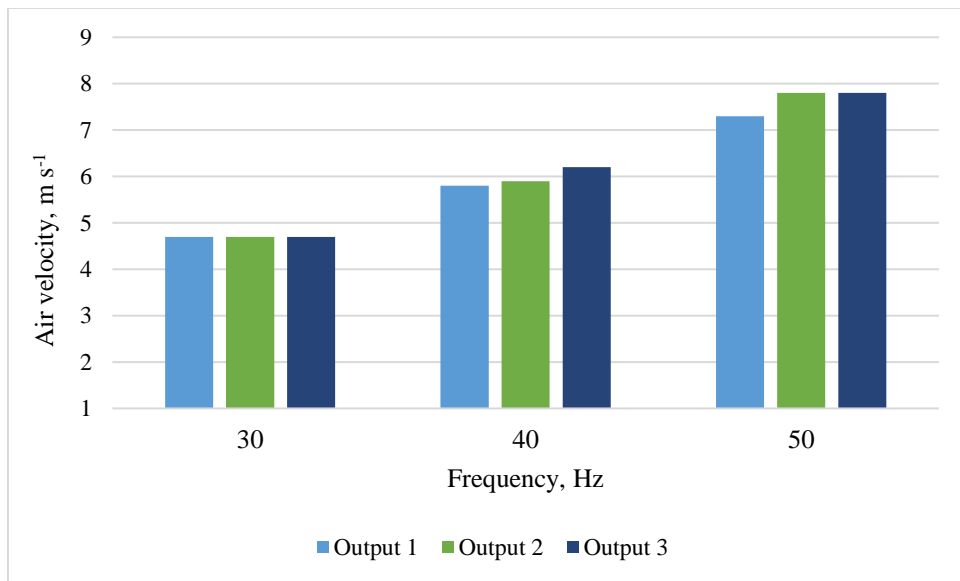


**Fig. 4.7 Variation of air velocity in case of straight 6-blade impeller**

In case of straight 4-blade impeller, variation in air velocity along the circumference was comparatively high ranging between  $3.3$  to  $3.8 \pm 0.1 \text{ m s}^{-1}$ . Air velocity along the circumference was limited to  $40 \text{ Hz}$  due to vibration and forward motion of experimental setup when operated at high frequency. Compared to other impellers, air velocity was very less because of the reduction in number of blades.



**Fig. 4.8 Air velocity along the circumference of straight 4-blade impeller (40 Hz)**



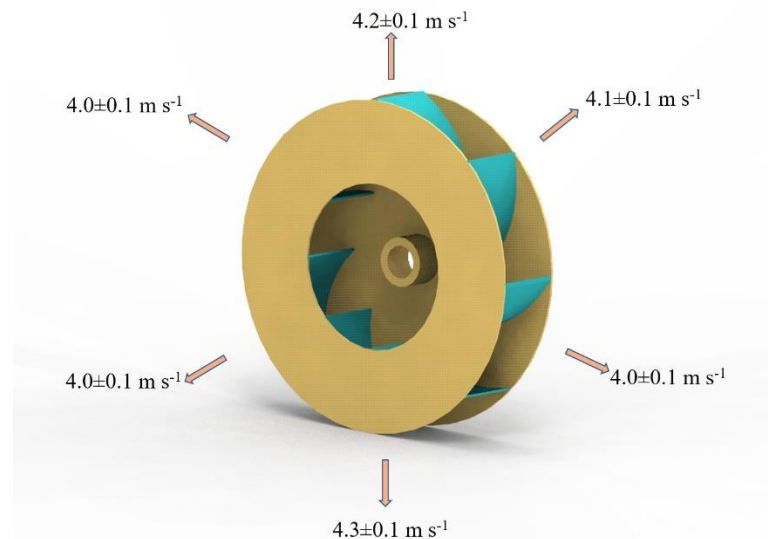
**Fig. 4.9 Variation of air velocity in case of straight 4-blade impeller**

At 30 Hz, variation in air velocity at the individual outlets was zero and the variation in air velocity increased with increase in impeller rpm to a larger extent. At 50 Hz, variation in air velocity at the outlet 1 was high compared to other outlets as shown in Fig.4.9. Average of air velocity at the outlets was found as  $4.7 \text{ m s}^{-1}$  at 30 Hz,  $6.0 \text{ m s}^{-1}$  at 40 Hz and  $7.6 \text{ m s}^{-1}$  at 50 Hz respectively.

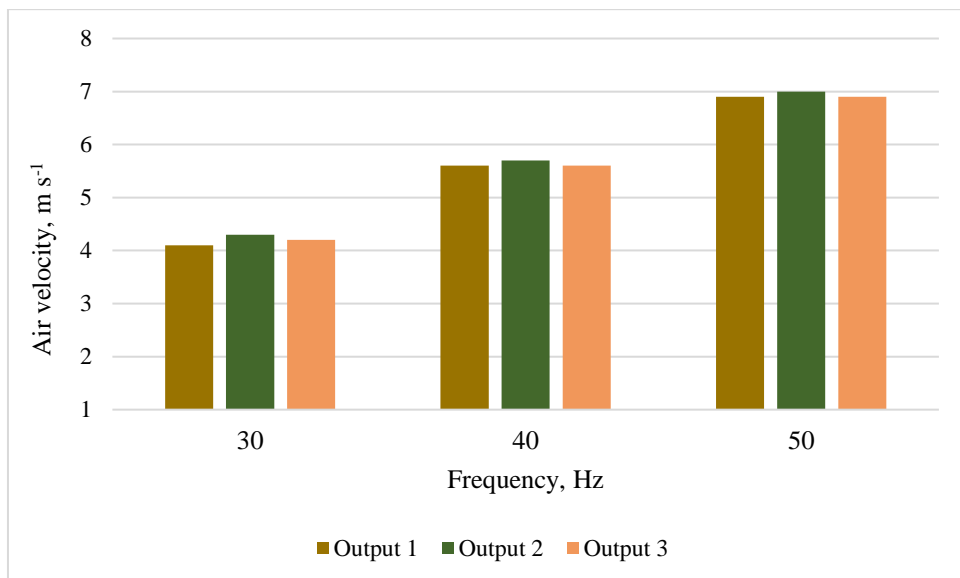
In case of radial impeller, air velocity along the circumference was comparatively same with minor variations ranging between  $4.0$  to  $4.3 \pm 0.1 \text{ m s}^{-1}$ . Air velocity along the



circumference was limited to 40 Hz due to larger vibration and forward motion of experimental setup when operated at high frequency. Compared to other impellers, air velocity was less but greater suction was observed due to its closed design resembling a centrifugal fan.



**Fig. 4.10 Air velocity along the circumference of radial impeller (40 Hz)**



**Fig. 4.11 Variation of air velocity in case of radial impeller**

At 30 Hz, variation in air velocity at the individual outlets was comparatively less and the variation in air velocity was very less with increase in impeller rpm. Variation in air velocity was less at 50 Hz as a result variation in discharge was minimum.

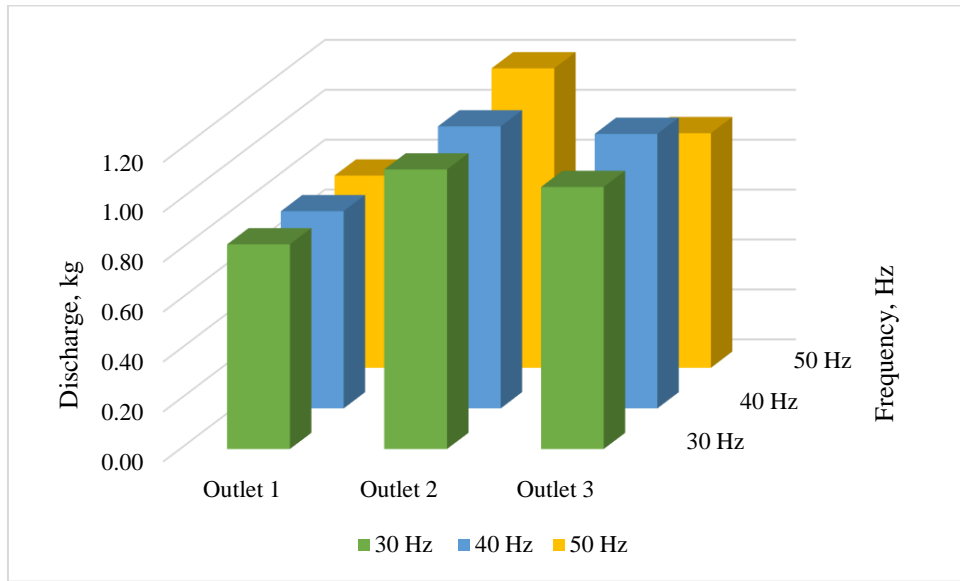
Average of air velocity at the outlets was found as  $4.2 \text{ m s}^{-1}$  at 30 Hz,  $5.6 \text{ m s}^{-1}$  at 40 Hz and  $6.9 \text{ m s}^{-1}$  at 50 Hz respectively.

The variations in air velocity can be further calibrated for zero variation but the aim of the model development was limited to check the suitability of type of impeller and to decide the rpm of impeller alone. Performance of all the impellers in creating suction and air velocity at outlets was found good in their own ways. Considering the suction and variation in air velocity alone, radial impeller and straight 6-blade impeller showed good readings.

#### **4.2.3 Variation in discharge at the outlets**

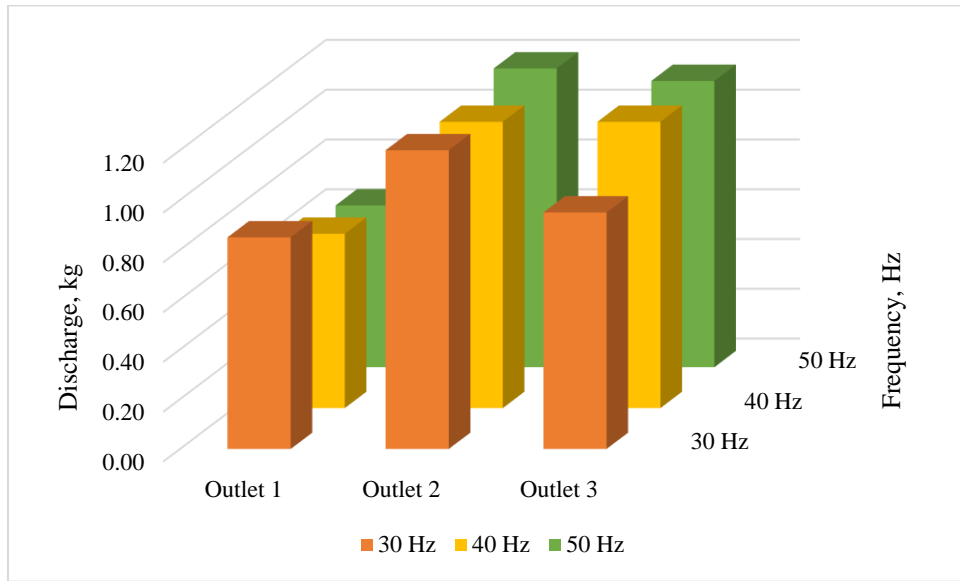
Although the blower outlets are not provided with any discharge adjustment, experiment setup was evaluated for variation in discharge to check the performance and discharge of each impeller. In the initial design when hopper was provided directly above the impeller, the air velocity prevented the manure input and created a lot of drift as shown in plate 3.11. Impellers are designed and developed considering theoretical assumptions and ASME standards. Discharge from the outlets are effected by the variation in air velocity and the impeller design. Design constraints like more number of blades, very less space provided between face of impeller and covering plate restricted the suction velocity in paddle type impeller. Since pitch length was restricted to 7.5 mm with 8 blades, it effected the discharge rate of manure and resulted in variation at the outlets.

Since outlet 2 was directly below the impeller and outlet 3 being the first discharge outlet (since motor rotation was in clock wise direction), discharge was high in both outlets 2 and 3 compared to outlet 1. By providing a valve control at each outlet, the discharge from each outlet can be regulated in further studies. Graph shows the variations in discharge at 3 outlets at 30, 40 and 50 Hz frequency.



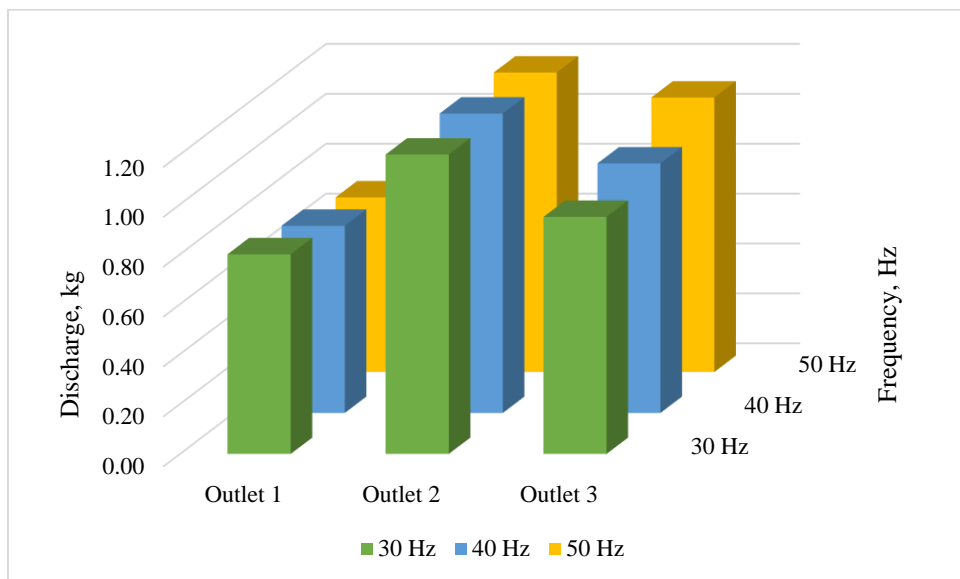
**Fig. 4.12 Variation of discharge w.r.to frequency in case of paddle type impeller**

In case of straight 6-blade impeller with flat blades, suction at the eye was good enough to create a -ve pressure that suck the manure and discharge it through the outlets at high velocity. Also 6 blades provided enough space to incorporate manure in between them and whirling action dissipated the manure through outlets. Direction of rotation of impeller inside the blower effected the variation in discharge at the outlets. Since rotation of impeller was in clockwise direction (outlets measured in anti-clockwise direction), the outlets that opens firstly to impeller gives more discharge compared to other outlets. Outlet 2 being directly below the impeller and outlet 3 being the first one to come in contact discharge was high compared to outlet 1. This variation in discharge at the outlets increased with increasing the impeller rpm. Variation in discharge was less than 15 % when operated at 1200 rpm and below which was considered the suitable condition for operating blower.



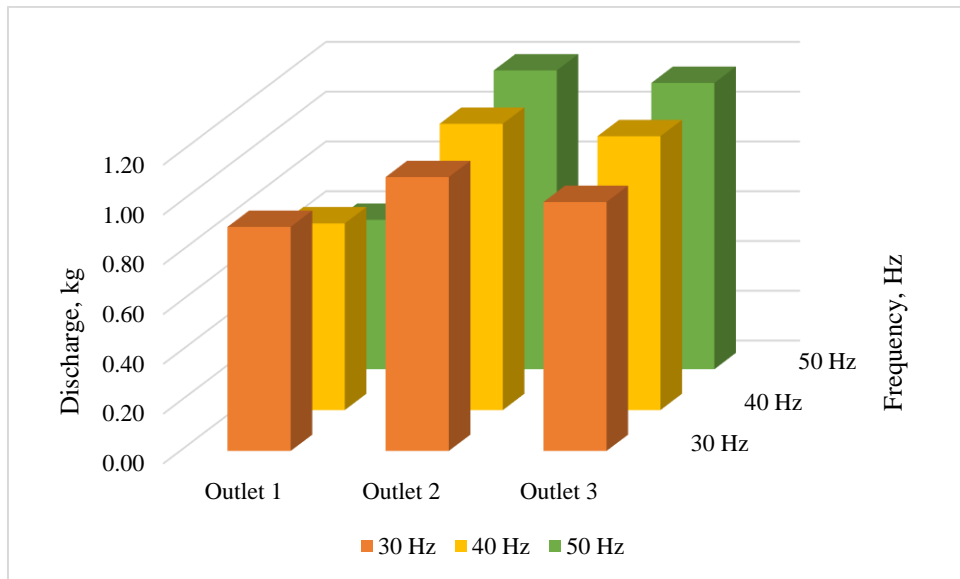
**Fig. 4.13 Variation of discharge w.r.to frequency in case of straight 6-blade impeller**

In case of straight 4-blade impeller suction at the eye is  $4.6 \text{ m s}^{-1}$  at 30 Hz which is good enough to suck the manure and dissipate it through the outlets at high velocity. Pitch length between the blades is large enough to incorporate maximum amount of manure in between them. As discussed above, outlet 2 being directly below the impeller and outlet 3 being the first one to come in contact discharge was high compared to outlet 1.



**Fig. 4.14 Variation of discharge w.r.to frequency in case of straight 4-blade impeller**

In case of closed radial impeller with curved blades, variation in discharge at the outlets was minimum at 30 and 40 Hz respectively compared to other impellers. Since suction at the eye was higher than other impellers, discharge of manure at the outlets is high. Since outlet 2 being directly below the impeller and outlet 3 being the first one to come in contact, discharge was high in outlet 2 and 3 compared to outlet 1.

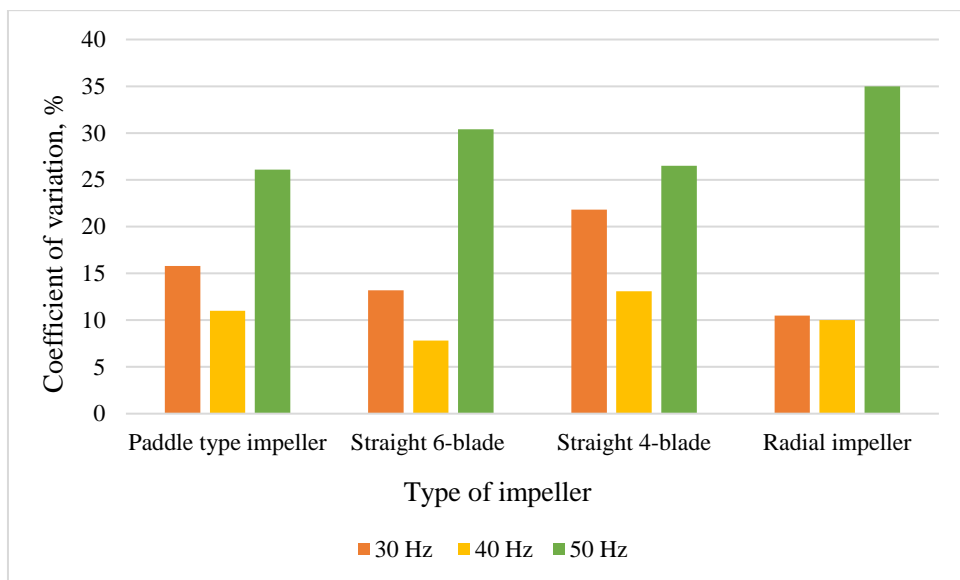


**Fig. 4.15 Variation of discharge w.r.to frequency in case of radial impeller**

#### 4.2.4 Coefficient of variation at the outlets

Outlets for the blower were developed by maintaining a 45° angle with each other and separated 50 mm apart. Performance of the outlets should be studied by testing for coefficient of variation in discharge at the outlets. The results can further be analysed for selection of impeller type and development of valve regulator at outlets. Since outlet 2 was directly below the impeller and outlet 3 being the first discharge outlet (since motor rotation is in clock wise direction), discharge was high in both outlets 2 and 3 compared to outlet 1 with respect to every impeller. Within the time impeller and manure reaches the outlet 1, more than 70 % of the manure gets discharged through outlet 2 and 3. Hence variation in discharge was high w.r.to outlet 1 and it increased with increasing frequency to 50 Hz. Variation in discharge at the outlets was less at 40 Hz which indicated the suitability of impeller rpm w.r.to its design.

Results showed that coefficient of variation was less when the blower was operated at lower rpm. Variation of discharge in outlets can be further nullified by arranging regulators in the development of blower prototype. Coefficient of variation with paddle type impeller were found out as 15.8 % at 30 Hz, 11.0 % at 40 Hz and 26.1 % at 50 Hz respectively. Coefficient of variation with straight 6-blade impeller were found out as 13.2 % at 30 Hz, 7.8 % at 40 Hz and 30.4 % at 50 Hz respectively. Coefficient of variation with straight 4-blade impeller were found out as 21.8 % at 30 Hz, 13.1 % at 40 Hz and 26.5 % at 50 Hz respectively. Coefficient of variation with radial impeller were found out as 10.5 % at 30 Hz, 10.0 % at 40 Hz and 35.0 % at 50 Hz respectively. Performance of radial impeller was good compared to other impellers with a lower CV at 30 and 40 Hz.

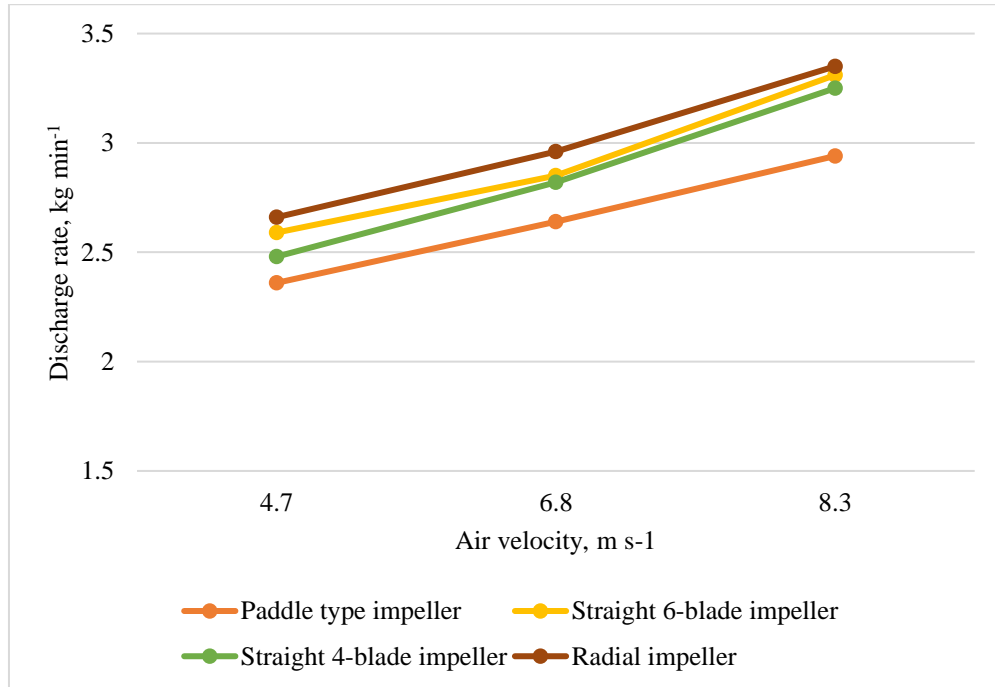


**Fig. 4.16 Coefficient of variation of discharge at outlets w.r.to frequency**

#### **4.2.5 Distribution of feed w.r.to airflow velocity**

Discharge rate of manure increased with increase in impeller rpm. Also change in impeller rpm changed the suction in eye and air velocity at the outlets which ultimately resulted in change in discharge rate. Design constraints of the impellers *viz.*, no. of blades and pitch angle restrict the discharge through outlets and effect the discharge rate. Paddle type impeller with 8 blades restrict the manure accumulation in between the blades such that it resulted in lower discharge rate as shown in Fig.4.17. Radial impeller being closed acts as a centrifugal fan and helps in larger suction and discharge.

The analysis of variance (ANOVA) in Table 2 in Appendix VII showed the effect of impeller rpm and air velocity ( $p < 0.0001$ ) on the discharge rate.



**Fig. 4.17 Discharge rate of manure w.r.to impeller rpm**

Air velocities *viz.*, 4.7, 6.8 and 8.3 m s<sup>-1</sup> represent the corresponding air velocities at 30, 40 and 50 Hz frequency. In case of paddle type impeller, change in discharge rate was minimum with 2.36 kg min<sup>-1</sup> at 30 Hz, 2.64 kg min<sup>-1</sup> at 40 Hz and 2.94 kg min<sup>-1</sup> at 50 Hz respectively. Discharge rate with straight 6-blade impeller were found out as 2.59 kg min<sup>-1</sup> at 30 Hz, 2.85 kg min<sup>-1</sup> at 40 Hz and 3.31 kg min<sup>-1</sup> at 50 Hz respectively. Discharge rate with straight 4-blade impeller were found out as 2.48 kg min<sup>-1</sup> at 30 Hz, 2.82 kg min<sup>-1</sup> at 40 Hz and 3.25 kg min<sup>-1</sup> at 50 Hz respectively. Discharge rate with radial impeller were found out as 2.66 kg min<sup>-1</sup> at 30 Hz, 2.96 kg min<sup>-1</sup> at 40 Hz and 3.35 kg min<sup>-1</sup> at 50 Hz respectively. Compared to other impellers, radial impeller was found to have a better discharge rate than other impellers.

Results from the laboratory blower model indicate the performance of all the impellers under various experimental conditions. Operating the model at 40 Hz showed best results with lesser vibration and moment. A paddle type impeller showed an average suction velocity of 4.9 m s<sup>-1</sup> with an outlet air velocity of 6.8 m s<sup>-1</sup>, coefficient of variation of 11 % and a discharge rate of 2.64 kg min<sup>-1</sup>. A straight 6-blade impeller

showed an average suction velocity of  $5.9 \text{ m s}^{-1}$  with an outlet air velocity of  $7.8 \text{ m s}^{-1}$ , coefficient of variation of 7.8 % and a discharge rate of  $2.85 \text{ kg min}^{-1}$ . A straight 4-blade impeller showed an average suction velocity of  $5.7 \text{ m s}^{-1}$  with an outlet air velocity of  $6.0 \text{ m s}^{-1}$ , coefficient of variation of 13.1 % and a discharge rate of  $2.82 \text{ kg min}^{-1}$ . A radial impeller showed an average suction velocity of  $5.9 \text{ m s}^{-1}$  with an outlet air velocity of  $5.6 \text{ m s}^{-1}$ , coefficient of variation of 10 % and a discharge rate of  $2.96 \text{ kg min}^{-1}$ .



#### 4.3 DEVELOPMENT OF MANURE PULVERIZER CUM APPLICATOR

The developed parts *viz.*, KAU manure pulverizer, feed chute, blower, frame & hitch, gearbox and extension shaft were assembled to form a tractor powered manure pulverizer cum applicator. Existing KAU manure pulverizer consisted of a 2 hp single phase electric motor as a prime mover. Drive to the pulverizer unit was taken from the gearbox in the present study making it a tractor driven implement. Developed unit was mounted on a tractor attached with p.t.o drive shaft. Gearbox divided the input rpm into two outputs at right angle to each other for driving pulverizer blade and blower. Pulverizer powdered the dried manure which was collected in the chute below the pulverizer unit. Deposited manure got sucked through the inlet into the blower and discharged through the outlets.

Provisions were made to adjust the valve opening, pulverizer and blower rpm. Discharge rate could be varied by changing the position of valve opening (full or half) and speed of blower rpm. Degree of pulverization was varied by changing the speed of rotation of pulverizer blade. Also by changing the length of outlet pipe the row to row spacings can be varied for different crop spacings.

**Table 4.2 Specification of KAU manure pulverizer**

Sl. No.	Particulars	Dimensions, cm
1	Prime mover	2 hp Electric motor
2	Pulverizing drum	52 × 30
	Capacity, m <sup>3</sup>	0.064
3	Feeding chute	56.5 × 72 × 30
	Shape	Trapezoidal
4	Rotating blade	22 × 4 × 0.6
5	Sieve	52 × 52 × 0.4
6	Supporting stand	56 × 56 × 70
7	Power transmission	Belt & pulley
	Type	Two double V-belt pulleys

**Table 4.3 Specification of prototype manure pulverizer cum applicator**

<b>Sl. No.</b>	<b>Particulars</b>	<b>Dimensions</b>
1	Over all dimensions	
	Length × width × height, mm	1534 × 880 × 1600
2	Specifications of tractor	
	i. Make and model	John Deere 5065-E
	ii. Power source, hp	65
3	Type of implement	Mounted and p.t.o driven
4	Number of rows	3
5	Row spacing, mm	600
6	Nominal working width, mm	1800
7	Hoppers	
	a) Pulverizer hopper	
	i. Shape	Cylindrical
	ii. Capacity, m <sup>3</sup>	0.064
	b) Chute	
	i. Shape	Cylindrical
	ii. Capacity, m <sup>3</sup>	0.029
	c) Blower inlet	
	i. Shape	Trapezoidal
	ii. Capacity, cm <sup>3</sup>	0.0002
8	Rotating blade dimensions, mm	220 × 40 × 6
9	Blower casing dimensions, mm	310 × 65 × 2
10	Impeller	
	i. Type	Closed radial impeller
	ii. No. of vanes	8
	iii. Effective diameter, mm	245
	iv. Width, mm	55
11	Supporting frame dimensions, mm	1545 × 882 × 430
12	Hitching standards	IS: 4468-2005
	Hitch system	Category II

13	Power transmission	
	Gearbox type	3-way right angle gearbox
	Power ratio	1:1.83
	Pulleys	Two-double V-belt pulleys
	Max. rpm at pulverizer blade	1480
	Max. rpm at blower impeller	990

---

#### 4.3.1 Machine parameters

Calibrating the machine parameters during laboratory testing helped in adjusting the blower to obtain desired manure application rate in the field. Changing the machine parameters *viz.*, p.t.o speed, blower speed, air flow rate and size of the valve opening effects the performance of the developed prototype.

##### 4.3.1.1 Engine rpm

Engine rpm of a tractor depends on the hp of individual tractor. On an average most of the tractors hp ranging between 40 hp and above have an engine rpm of 2500 rpm. When engine rpm reaches 2500 rpm, the rpm at the p.t.o reads 540. Hence engine rpm effects the performance of the developed prototype. Likewise Change in input p.t.o speed changes the corresponding gearbox output speeds that affects the prototype working. Variation in pulverizer blade rpm and blower rpm w.r.to engine rpm or p.t.o speed is shown in Fig.3.17 and tabulated in Appendix VIII.

##### 4.3.1.2 Blower speed

Blower sucks the manure and dissipates it through the outlets. Changing the blower input speed effects both the suction and output air velocity. Although blade dimensions were kept constant, change in air flow rate per minute effects the performance of blower. So prototype was calibrated to obtain an optimum impeller rpm such that performance of the blower unit will be good. Also application rate of the manure is effected with changing impeller rpm.

#### ***4.3.1.3 Size of valve opening***

Output capacity of pulverizer was  $500 \text{ kg h}^{-1}$  at a pulverizer blade speed of 1440 rpm. Changing the pulverizer blade rpm increased the degree of pulverization but not the capacity of pulverizer. So a constant amount of pulverized manure is being deposited in the chute. In order to dissipate the manure or operate the blower, certain amount of manure should be made available in the chute. Hence a valve opening was provided directly below the chute to regulate the discharge, coefficient of uniformity and application rate.

#### **4.3.2 Laboratory testing**

Laboratory test of prototype manure pulverizer cum applicator was conducted in research workshop, KCAET Tavanur. The prototype manure pulverizer cum applicator as an attachment to tractor was attached to 65 hp tractor through three-point linkage.

Tractor powered manure pulverizer cum applicator is a field manure application unit which works by means of a p.t.o. Manure pulverizer cum applicator was calibrated in the laboratory to determine the suction velocity, variation in discharge and discharge rate w.r.to engine rpm. Calibration was conducted to test and adjust the blower to obtain desired manure application rate in the field. Variation of suction velocity with impeller rpm, variation of air velocity at blower outlets, variation of discharge at the outlets due to change in impeller rpm, effect of engine rpm or p.t.o. speed on discharge rate and variation in CU due to change in blower rpm were studied. The calibration test results are discussed in the following sections.

##### ***4.3.2.1 Variation in gearbox output speeds due to variation in engine rpm***

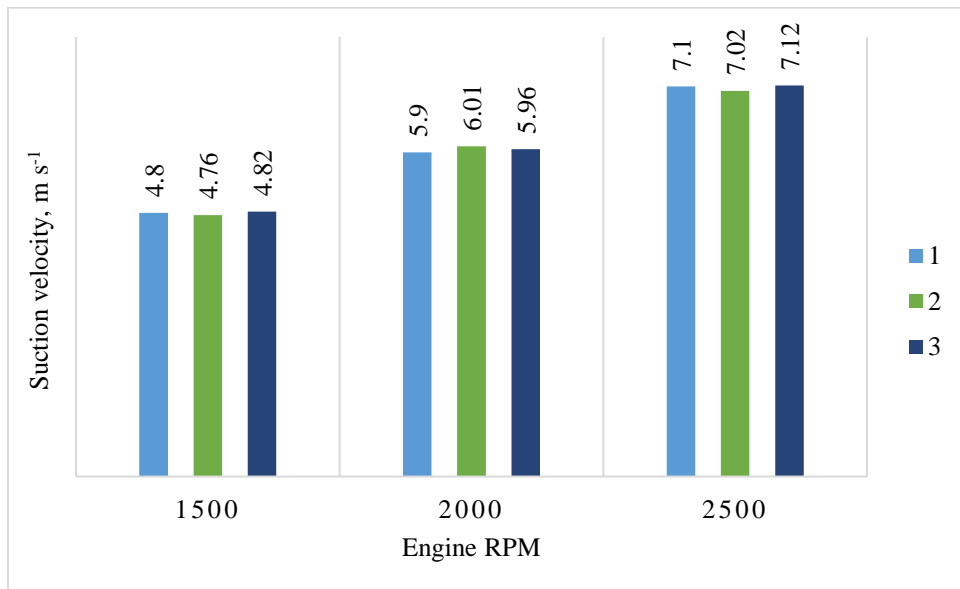
Engine rpm or p.t.o rpm are the primary driving units in a tractor. Maximum rpm at the p.t.o is obtained by running the tractor at maximum engine rpm. A gearbox was developed with a power ratio of 1.85 between p.t.o and gearbox output shafts. Variation in gearbox output speeds due to variation in engine rpm was shown in following Table 4.4.

**Table 4.4 Variation in gearbox output speeds**

Sl. No.	Engine rpm	P.T.O. speed	Blade rpm	Impeller rpm
1	1500	320	600	600
2	2000	430	800	800
3	2500	540	990	990

#### 4.3.2.2 Variation of suction velocity with impeller rpm

Results from the laboratory blower model indicated that the performance of the radial impeller was good compared to the other impeller. Hence a radial impeller was preferred over other impellers in the development and evaluation of blower prototype. To prevent drift due to leakage, an air tight casing was created and impeller strength was also increased. Changing the impeller input speed at 600,800 and 990 rpm, the suction at the eye was measured. Suction velocity at the inlet was found out to be 4.79  $\text{m s}^{-1}$  at 600 rpm, 5.96  $\text{m s}^{-1}$  at 800 rpm and 7.08  $\text{m s}^{-1}$  at 990 rpm.

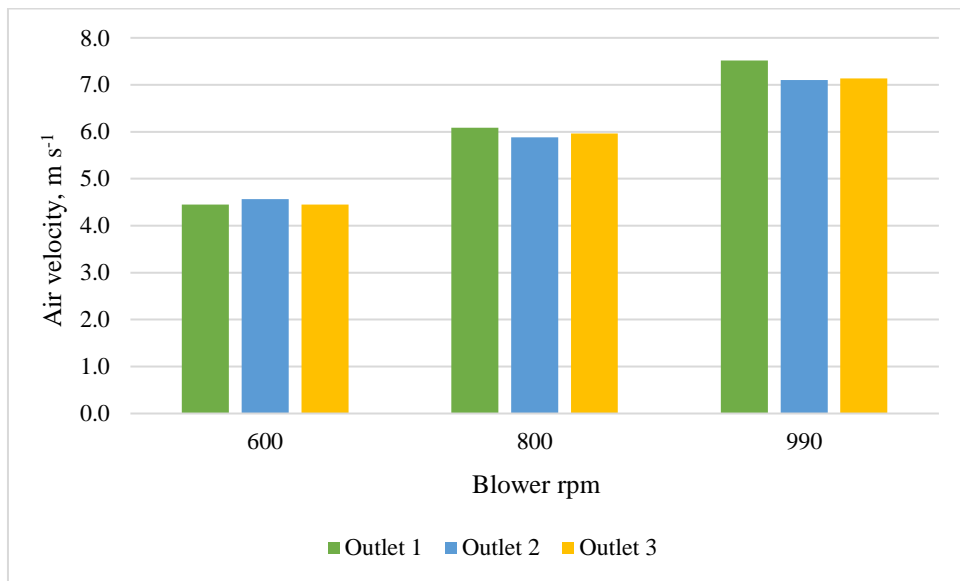
**Fig. 4.18 Variation in suction velocity with impeller rpm**

#### 4.3.2.3 Variation of air velocity at blower outlets

Air velocity inside the blower and at the outlets decides the path of manure. Pulverized manure is little coarse and fine in nature which is easily sucked, lifted and

thrown from the outlets. In the laboratory blower model, closed radial impeller showed a good suction and discharge. A radial impeller at 1000 rpm showed a suction and discharge of  $4.3 \text{ m s}^{-1}$  and  $2.7 \text{ kg min}^{-1}$ .

The analysis of variance (ANOVA) in Table 2 in Appendix X showed the variation of air velocity ( $p < 0.0001$ ) at the discharge outlets. In case of prototype evaluation, impeller was evaluated at varying input rpm of 600, 800 and 990 rpm. Increasing the input rpm increased the air velocity at the outlets which helped in increasing the manure discharge. To prevent the variation in air velocity and discharge, regulators were provided at each outlet. Hence variation in air velocity at the individual outlets was very less and the average of air velocity at the outlets was found to be  $4.41 \text{ m s}^{-1}$  at 600 rpm,  $6.0 \text{ m s}^{-1}$  at 800 rpm and  $7.18 \text{ m s}^{-1}$  at 990 rpm.



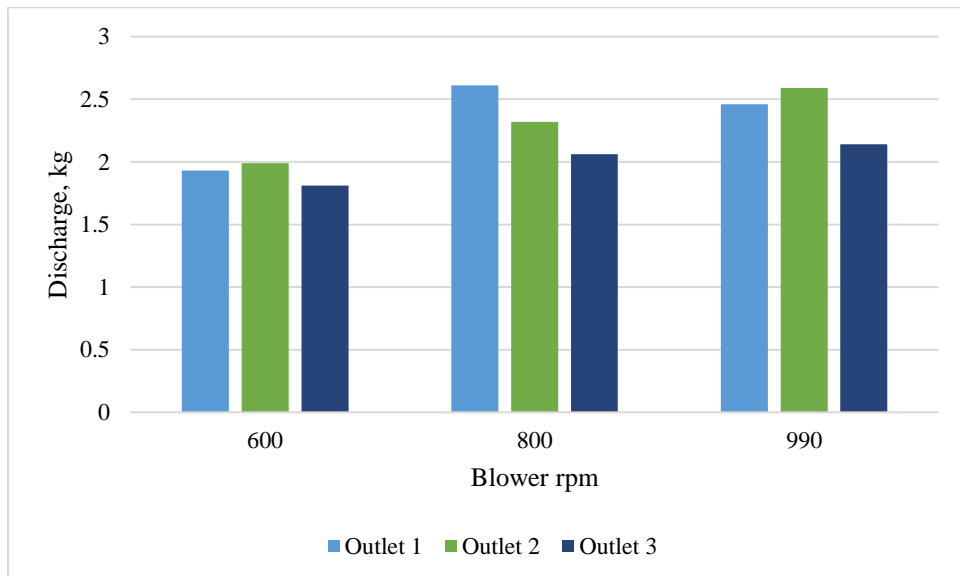
**Fig. 4.19 Variation in air velocity with blower rpm**

#### ***4.3.2.4 Variation in discharge due to change in impeller rpm (Full valve open)***

Variation in discharge at the outlets can be prevented by adjusting the valve regulators provided at individual outlets. Laboratory testing was carried out to observe the degree of variation in discharge such that it can be adjusted at various positions to nullify the discharge variation. Calibration of outlets were helpful in achieving equal discharge at every outlet while working in rows. Testing was carried out changing the

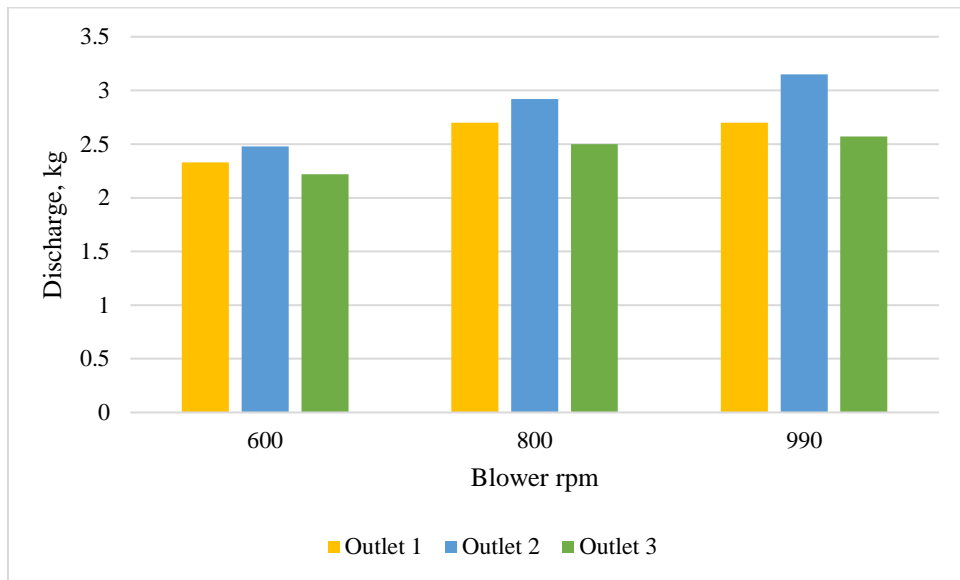
impeller rpm, adjusting the valve position and manure type. Cow dung, goat faecal pellets and neem cake are used in laboratory testing.

Increasing the blower rpm increased the discharge from outlets along with some variation in discharge. Pulverized cow dung is less dense, fine powdered and easily air driven in nature. At 600 rpm of the impeller, manure gets enough time to distribute between the outlets resulting in less variation. Errors in the design of developed blower outlets resulted in variation of discharge which can be further calibrated to achieve lesser variation. With increasing the impeller rpm at full valve open condition, variation in discharge at the outlets increased along with increased discharge as shown in Fig.4.20.



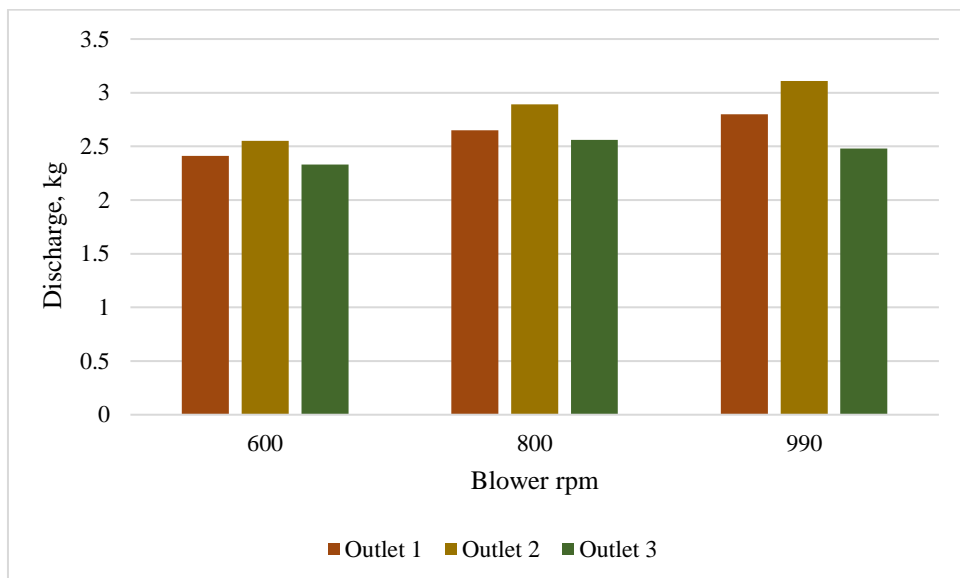
**Fig. 4.20 Variation in discharge with blower rpm using cow dung**

Pulverized goat faecal pellets are coarse, dense and requires more terminal velocity to lift and dissipate the manure. Because of its dense nature quantity of manure dissipation through outlets is more compared to cow dung. An appreciable discharge with less variation at outlets is obtained at 600 rpm and it gradually increases with blower rpm.



**Fig. 4.21 Variation in discharge with blower rpm using goat faecal pellets**

Similar to goat faecal pellets, powdered neem cake is dense and occupies less volume. At 600 rpm of blower, manure gets enough time to distribute between the outlets resulting in lesser variation. Increasing the blower rpm, variation at outlets increases along with increased discharge.



**Fig. 4.22 Variation in discharge with blower rpm using neem cake**

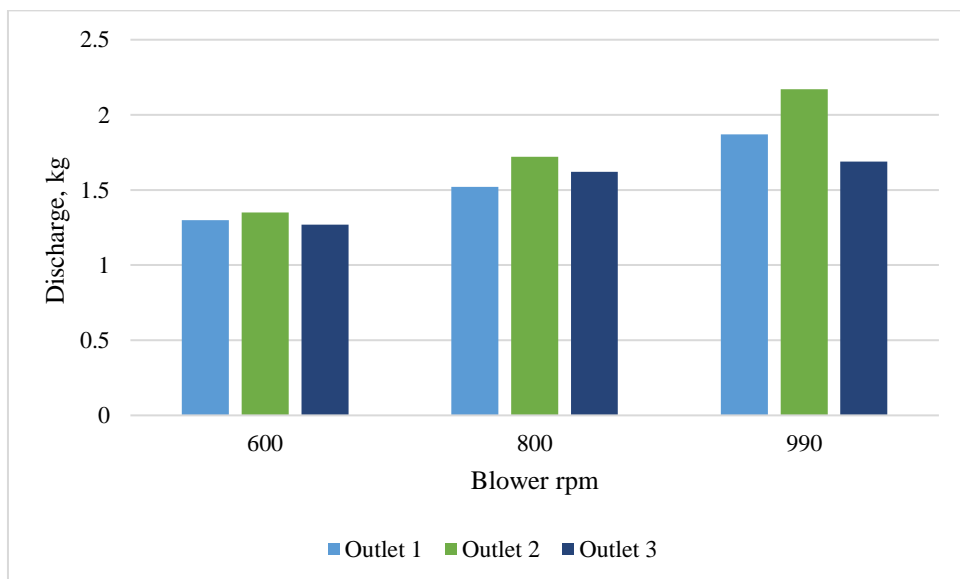
Through all the graphs it is clear that the variation in discharge at the outlets was same at every respective blower rpm and manure type. In all the cases discharge through



outlet 2 is quite more than the other outlets. So in order to get equal discharges at outlets, valve regulator at outlet 2 was lifted up to create an obstruction and also valve regulator at outlet 1 was lifted such that feed from outlet 2 will be shifted into outlet 1 resulting in equal discharge at 3 outlets.

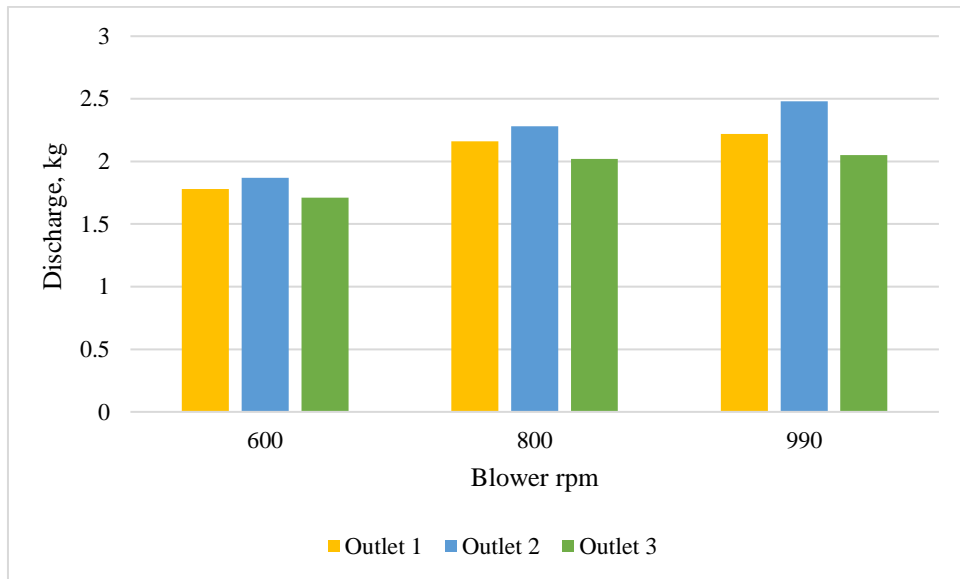
#### 4.3.2.5 Variation in discharge due to change in impeller rpm (Half valve open)

Changing the position of the valve effects the discharge at individual outlets and total quantity of discharge. Keeping the valve half open acts as an obstruction and prevents the free fall of incoming manure into the blower unit. As a result discharge from the outlets was reduced. Pulverized cow dung is less dense, fine powdered and easily air driven in nature. At 600 rpm of the impeller, manure gets enough time to distribute between the outlets resulting in less variation. Errors in the design of developed blower outlets resulted in variation of discharge which can be further calibrated to achieve lesser variation. With increasing the impeller rpm at half valve open condition, variation in discharge at the outlets increased along with increased discharge as shown in Fig.4.23. In all the cases discharge at the outlet 2 was more than other two outlets. A valve regulator arranged at outlet 1 and 2 help in distributing discharge equally through all the outlets. Further during field evaluation valves were arranged to obtain equal discharge at outlets.



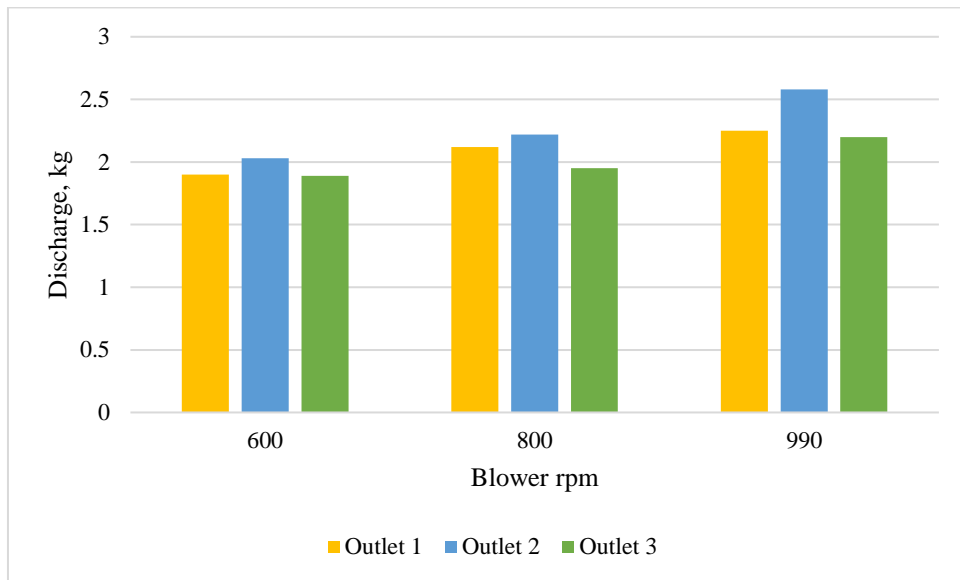
**Fig. 4.23 Variation in discharge with blower rpm using cow dung**

Pulverized goat faecal pellets are coarse, dense and requires more terminal velocity to lift and dissipate the manure. Because of its dense nature quantity of manure dissipation through outlets is more compared to cow dung. An appreciable discharge with less variation at outlets is obtained at 600 rpm and it gradually increased with blower rpm.



**Fig. 4.24 Variation in discharge with blower rpm using goat faecal pellets**

Manure flows through the half opening after overcoming the angle of repose which incurs loss of time and decreases the discharge. Similar to goat faecal pellets, powdered neem cake is dense and occupies less volume. At 600 rpm of blower, manure gets enough time to distribute between the outlets resulting in lesser variation. Increasing the blower rpm, variation at outlets increases along with increased discharge.

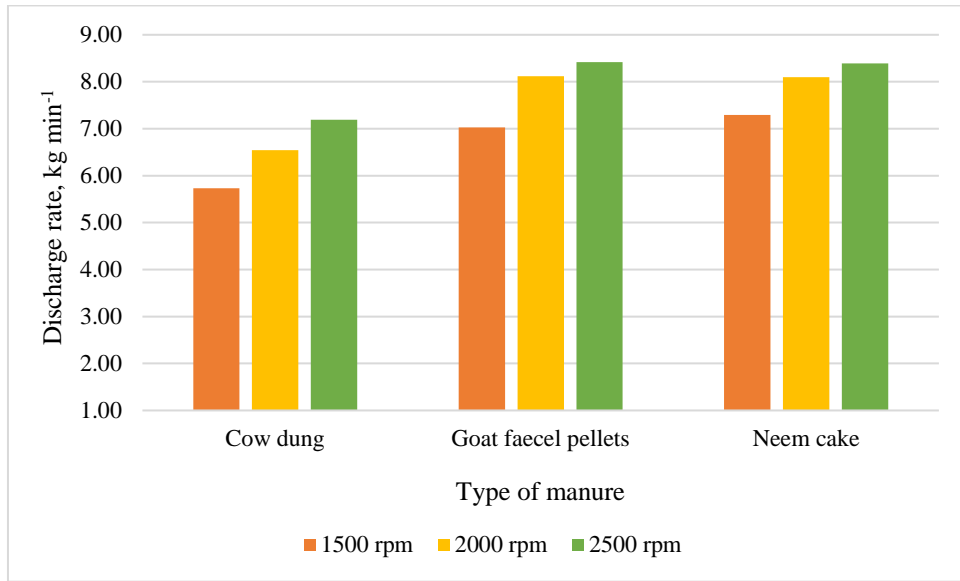


**Fig. 4.25 Variation in discharge with blower rpm using neem cake**

#### **4.3.2.6 Effect of engine rpm on discharge rate (Valve at fully opened condition)**

Discharge rate of cow dung was less than the discharge of goat faecal pellets and neem cake because of the differences in density. Density of goat faecal pellets and neem cake are almost same resulting in a more or less equal discharge rate. As a result discharge rate was high with goat faecal pellets and neem cake resulting in larger application rate in the field. Because of its less dense nature cow dung takes more time to deliver through the outlets keeping its application rate low. Discharge rate of developed prototype with cow dung was found out to be  $5.73 \text{ kg min}^{-1}$  at 600 rpm,  $6.54 \text{ kg min}^{-1}$  at 800 rpm and  $7.19 \text{ kg min}^{-1}$  at 990 rpm.

Density of goat faecal pellets ranges between  $0.480$  to  $0.505 \text{ kg cm}^{-3}$  which makes it easy to accommodate and dissipate through the blower. Discharge rate of developed prototype with goat faecal pellets was found out to be  $7.03 \text{ kg min}^{-1}$  at 600 rpm,  $8.12 \text{ kg min}^{-1}$  at 800 rpm and  $8.42 \text{ kg min}^{-1}$  at 990 rpm. Physical properties of the neem cake *viz.*, coarse and dense in nature allows manure to settle between the blades and dissipate it through the outlets. Discharge rate of developed prototype with neem cake was found out to be  $7.29 \text{ kg min}^{-1}$  at 600 rpm,  $8.10 \text{ kg min}^{-1}$  at 800 rpm and  $8.39 \text{ kg min}^{-1}$  at 990 rpm.

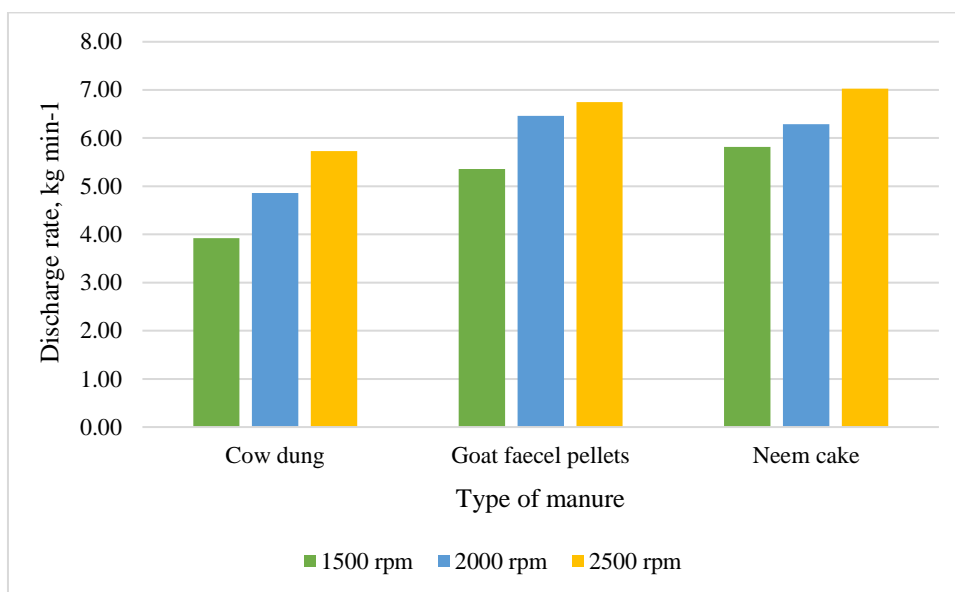


**Fig. 4.26 Variation in discharge rate with blower rpm**

#### ***4.3.2.7 Effect of engine rpm on discharge rate (valve at half opened condition)***

Discharge regulator valve acts an obstruction between the chute and blower unit preventing the flow of manure. In this case valve is kept half open and flow of manure is restricted until the manure overcomes its angle of repose. Physical properties of the manure and rpm of the impeller effect the flow and discharge rate of manure. Denser manure takes less space with more weight making it highly dischargeable whereas less dense manure takes more volume resulting in a less discharge rate. Increasing the rpm of impeller increased the rate of discharge as shown in Fig.4.27.

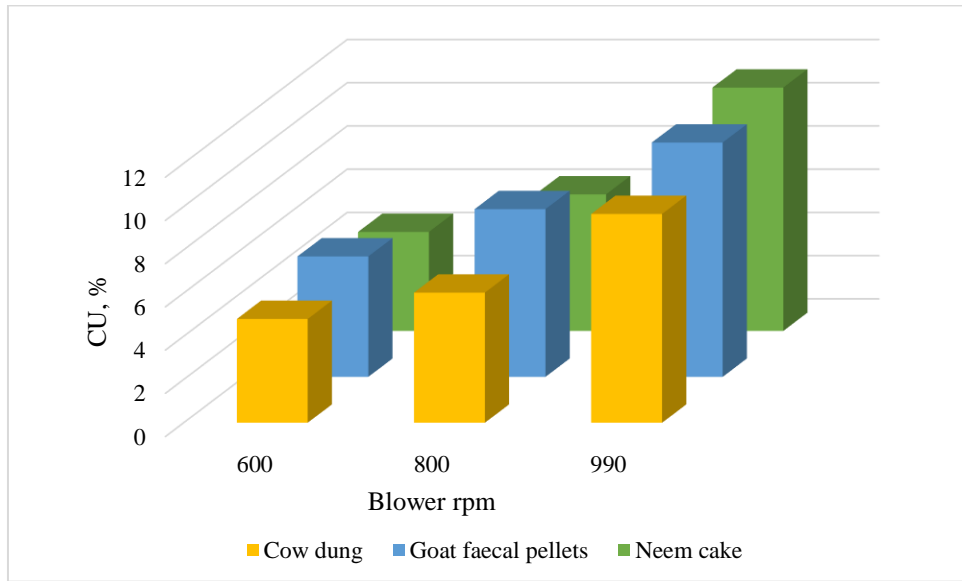
To match the discharge rate of blower unit with field requirement, it is necessary to regulate the travelling speed along with blower rpm. Discharge rate of developed prototype with cow dung was found out to be  $3.92 \text{ kg min}^{-1}$  at 600 rpm,  $4.86 \text{ kg min}^{-1}$  at 800 rpm and  $5.73 \text{ kg min}^{-1}$  at 990 rpm. Discharge rate of developed prototype with goat faecal pellets was found out to be  $5.36 \text{ kg min}^{-1}$  at 600 rpm,  $6.46 \text{ kg min}^{-1}$  at 800 rpm and  $6.75 \text{ kg min}^{-1}$  at 990 rpm. Discharge rate of developed prototype with neem cake was found out to be  $5.82 \text{ kg min}^{-1}$  at 600 rpm,  $6.29 \text{ kg min}^{-1}$  at 800 rpm and  $7.03 \text{ kg min}^{-1}$  at 990 rpm.



**Fig. 4.27 Variation in discharge rate with blower rpm**

#### ***4.3.2.8 Variation in CU due to change in blower rpm (valve at full opened condition)***

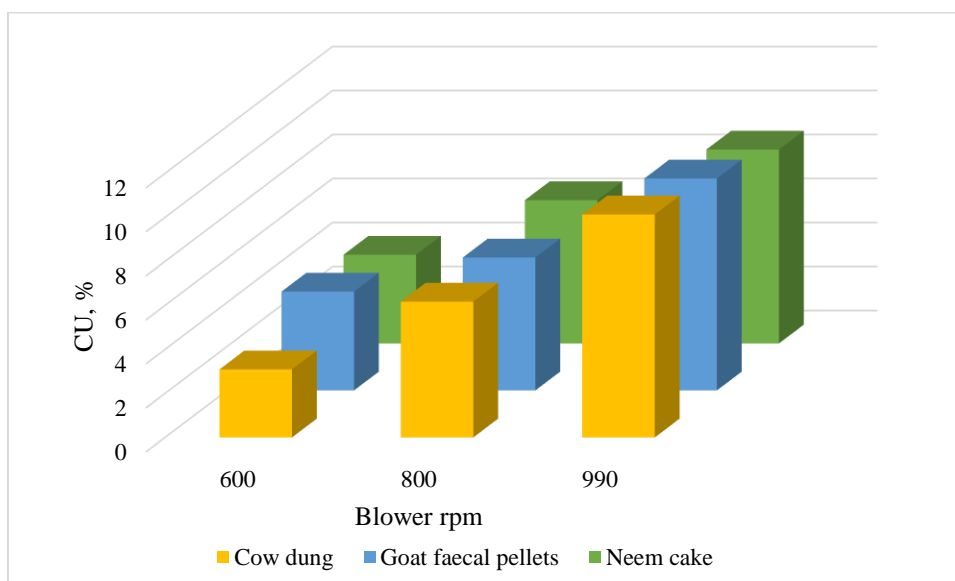
Maintaining appreciable uniformity at the outlets allows equal discharge of manure in the rows. Variation in uniformity increased with increasing blower rpm. In all the cases coefficient of uniformity is  $\pm 10\%$  which is appreciable in field condition. Coefficient of uniformity at the outlets with cow dung was found to be 4.8 % at 600 rpm, 6.02 % at 800 rpm and 9.66 % at 990 rpm respectively. Coefficient of uniformity at the outlets with goat faecal pellets was found to be 5.57 % at 600 rpm, 7.76 % at 800 rpm and 10.84 % at 990 rpm respectively. Coefficient of uniformity at the outlets with neem cake was found to be 4.58 % at 600 rpm, 6.32 % at 800 rpm and 11.26 % at 990 rpm respectively.



**Fig. 4.28 Variation in CU with blower rpm**

#### **4.3.2.9 Variation in CU due to change in blower rpm (valve at half opened condition)**

In case of half opened valve, variation in uniformity at the outlets is a bit less than that of full valve opened condition. Coefficient of uniformity at the outlets with cow dung was found to be 3.09 % at 600 rpm, 6.17 % at 800 rpm and 10.13 % at 990 rpm respectively. Coefficient of uniformity at the outlets with goat faecal pellets was found to be 4.49 % at 600 rpm, 6.04 % at 800 rpm and 9.63 % at 990 rpm respectively. Coefficient of uniformity at the outlets with neem cake was found to be 4.03 % at 600 rpm, 6.51 % at 800 rpm and 8.81 % at 990 rpm respectively. In order to achieve zero variation at the outlets, discharge regulators provided at outlets 1 and 2 are adjusted to get equal discharges at individual outlets.



**Fig. 4.29 Variation in CU with blower rpm**

#### 4.4 FIELD TESTING

Field testing of prototype manure pulverizer cum applicator was conducted in farm, KCAET Tavanur. The prototype manure pulverizer cum applicator as an attachment to tractor was attached to 65 hp tractor through three-point linkage and p.t.o is attached to gearbox with a drive shaft.

##### 4.4.1 Field capacity

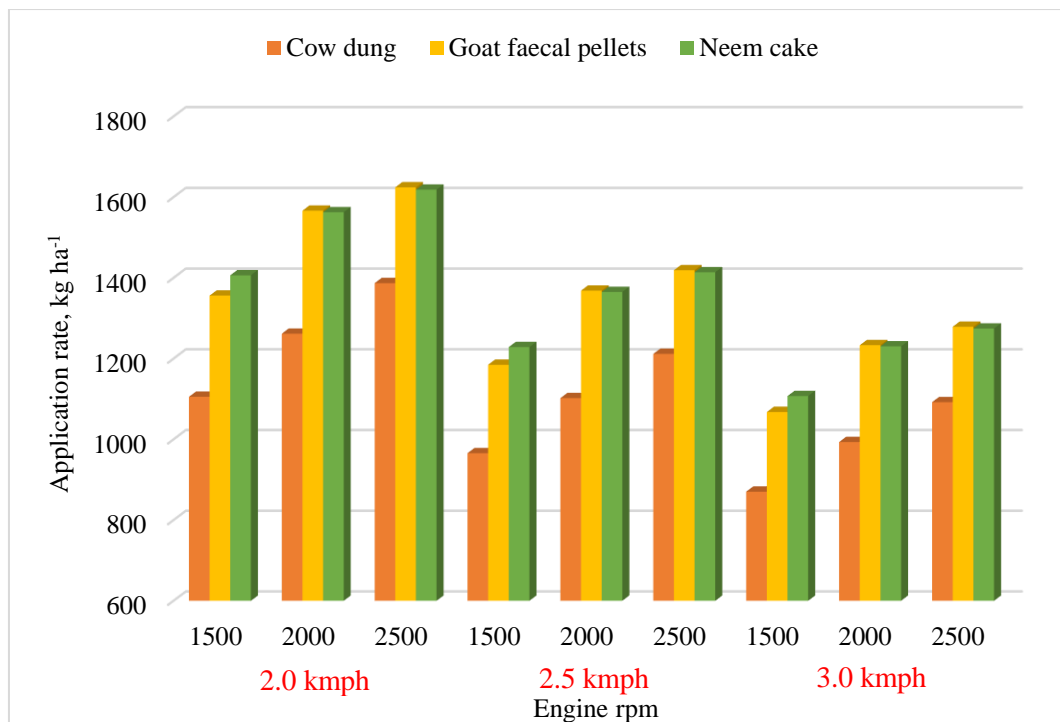
Prototype was evaluated at a forward speeds of 2.0 km h<sup>-1</sup> at gear L<sub>1</sub> (high), 2.5 km h<sup>-1</sup> at gear L<sub>2</sub> (low) and 3.0 km h<sup>-1</sup> at gear L<sub>2</sub> (high). Increasing the travelling speed resulted in a decreased field efficiency.

The actual field capacity and efficiency of manure pulverizer cum applicator was found out to be 0.311 ha h<sup>-1</sup> and 86.5 % at a forward speed of 2.0 km h<sup>-1</sup>, 0.356 ha h<sup>-1</sup> and 79.2 % at a forward speed of 2.5 km h<sup>-1</sup> and 0.395 ha h<sup>-1</sup> and 73.1 % at a forward speed of 3.0 km h<sup>-1</sup>. Maximum field capacity was noted at a traveling speed of 3.0 km h<sup>-1</sup>. Field capacity and field efficiency of tractor powered manure pulverizer cum applicator were calculated and given in Appendix XIV.

#### 4.4.2 Application rate

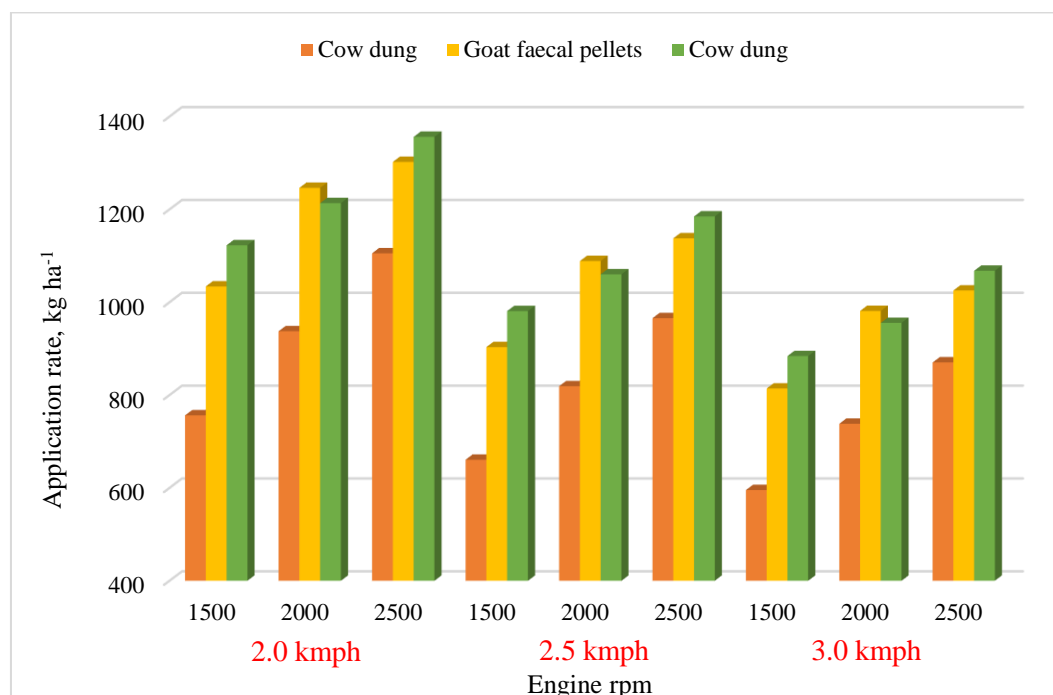
Forward speed of the travel was inversely proportion to the application rate of the manure. Travelling at a lower speed result in a larger application rate which was good but resulted in a lesser field capacity. A larger application rate of 1387.1 kg ha<sup>-1</sup> for cow dung, 1624.4 kg ha<sup>-1</sup> for goat faecal pellets and 1618.6 kg ha<sup>-1</sup> for neem cake was found at an engine rpm of 2500, forward speed of 2 km h<sup>-1</sup> with a field capacity of 0.31 ha h<sup>-1</sup>. With increasing the forward speed to 2.5 and 3.0 km h<sup>-1</sup>, field capacity as well as application rate decreased.

In case of valve at half open position, larger application rate of 1105.5 kg ha<sup>-1</sup> for cow dung, 1302.3 kg ha<sup>-1</sup> for goat faecal pellets and 1356.3 kg ha<sup>-1</sup> for neem cake was found at an engine rpm of 2500, forward speed of 2 km h<sup>-1</sup> with a field capacity of 0.31 ha h<sup>-1</sup>.



**Fig. 4.30 Effect of engine rpm and travelling speed on application rate of manure (Valve at full open condition)**





**Fig. 4.31 Effect of engine rpm and travelling speed on application rate of manure (Valve at half open condition)**

Based on the field studies, the time required for manure application per ha ranged between 3 to 3.5 h at a travelling speed of 2 kmph.

#### 4.4.3 Optimization of operational parameters

For Okra where the crop is raised in ridges and furrows at a row to row spacing of 60cm, the FYM recommendations as per POP, KAU (2016) is 20t, which is applied as a basal dose. In the case of neem cake it is approximately 4 t ha<sup>-1</sup>. The discharge chutes of the developed unit i.e., manure pulverizer cum applicator was provided with flexible pipes which help in achieving various row to row spacings for different crops. Valve control mechanism helped in varying the discharge such that larger application rates can be achieved for less dense manures.

From the Fig. 4.30 and 4.31, it is clear that the application rate of cow dung was less compared to goat faecal pellets and neem cake because of its less dense nature. So dosage recommended for cow dung is more compared to other manures. It can be achieved by keeping the valve in full open condition and operating the machine at less travelling speed. From the table 4.5, it is clear that more than 1600 kg ha<sup>-1</sup> of goat faecal

matter and neem cake can be achieved when the travelling speed was limited to 2.0 kmph. Similarly when the traveling speed is reduced from 3.0 to 2.0 kmph, a larger application rate was achieved.

Feeding rate also affects the application rate of manure. Since cow dung is less dense, it can be easily pulverized inside the drum within short period. Also chute below the pulverizing drum was made large and fully open condition which helps in accommodating more powdered manure during field operation to get the required dosage. Readings in table 4.5 shows the application rates of selected manures per pass in hectare of land. To achieve larger application rates, number of passes should be increased.

**Table 4.5 Application rates of selected types of manures (for one pass)**

Sl. No.	Travelling speed, kmph	Engine rpm	Application rate achieved in one pass of application (Full valve)		
			Cow dung	Goat faecal pellets	Neem cake
1	2.0	2500	1387.1	1624.4	1618.6
2	2.5	2500	1211.8	1419.1	1414.0
3	3.0	2500	1092.2	1279.0	1274.4

In the case of Okra, multiple passes of application (for cowdung and goat faecal matter approximately 15 passes and neem cake 3 passes) will be required for application in one ha.

#### **4.4.4 Effect of blade rotational speed on degree of pulverization**

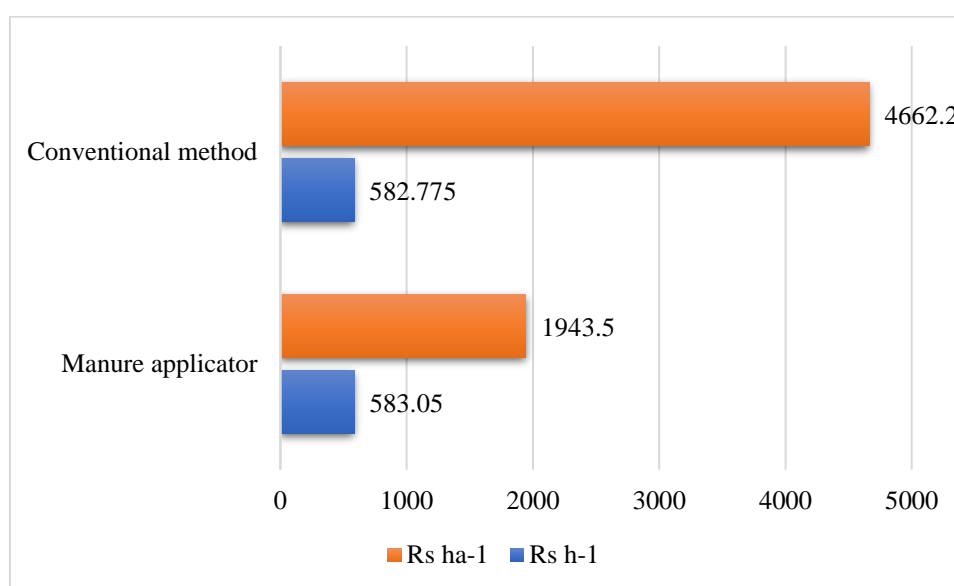
In order to check the effect of rotational speed of pulverizer blade on the discharge rate, four double V-belt pulleys of various sizes were selected (Fig.3.29). Increase in the rotational speed of the blade effected the fineness of manure irrespective of its discharge. Degree of pulverization increased with increasing the velocity ratio between the driver and driven pulleys.

#### 4.4.5 Fuel consumption

Fuel consumption of the tractor powered manure pulverizer cum applicator was measured by attaching an external fuel consumption measuring jar with the tractor fuel tank. The fuel consumption was measured in both  $l\ h^{-1}$  and  $l\ ha^{-1}$  and found out to be  $3.5\ l\ h^{-1}$  and  $28\ l\ ha^{-1}$ .

#### 4.5 COST ECONOMICS

The cost economics of tractor powered manure pulverizer cum applicator was given in Appendix XIX. The cost of manure pulverizer cum applicator alone is Rs. 64,000 (Appendix XVIII). Cost of operation of manure pulverizer cum applicator as an attachment to tractor as explained in Section 3.4 was found as  $583.05\ Rs\ h^{-1}$  and  $1943.5\ Rs\ ha^{-1}$ . Cost of manual manure application followed by manure pulverization was  $582.7\ Rs\ h^{-1}$  and  $4662.2\ Rs\ ha^{-1}$ . The benefit-cost ratio of the developed machine was 1.4:1.



**Fig. 4.32 Cost economics of convention practices Vs manure applicator**

# SUMMARY AND CONCLUSION

## CHAPTER V

### SUMMARY AND CONSLUSION

Agricultural production needs to be stepped up to meet the increasing demand of the expanding population of India. This can be attained through higher crop productivity on a sustained basis, since expansion of cultivable area has a little scope. Yield improvement could be achieved through the use of HYV and fertilizers. However, it has been realized that the continued application of chemical fertilizers deteriorates soil qualities and on the other hand, application of organic manures help in building up fertility levels and improves soil quality.

Organic manures such as farm yard manure, green manure etc., when incorporated into the soil not only add nutrients but enriches the soil by the fixation of atmospheric nitrogen. The experiments with farm yard manure have shown that the physical properties of soil are improved when compared to the soil treated with chemical fertilizers. Manures (FYM, vermicompost, edible oil cakes etc..) are an important resources which provide nutrients that could reduce bagged fertilizer costs and improves the crop growth and performance. A well-managed manure is a valuable resource in providing nutrients for crop production. Use of farm yard manure and other organic manure is the way out to overcome the problems of soil degradation, loss of fertility and soil health.

A larger portion of nitrogen is made available as and when the FYM decomposes. Application of FYM improves soil fertility and therefore there is wide scope for its application. Also, the application of recommended doses of manures at the proper time would stabilize the soil fertility status and hence improves soil productivity. Manure gets decomposed as soon as it put on the soil by the microorganisms present in the soil. To speed up the decomposition process, it is necessary to break up the manure clods and make more surface area expose to the micro organisms. Lesser the manure clod size better the surface area exposed for the attack of micro organisms.

KAU manure pulverizer consisted of an electric motor, pulverizing drum, transmission unit, feeding chute, rotating blade, sieve and stand. Dried manure reaches the pulverizing drum from the feeding chute and rotating blades help in pulverizing the

manure due to impact and shear force. Manure remains over the sieve until it attains a size smaller than the size of the sieve. In order to overcome the non-availability of electric power in remote areas and fields, use of tractor power is a viable solution. For operating in such situations, use of tractor p.t.o for operating a pulverizer along with applicator is an added advantage. Hence it is envisaged to utilize the tractor p.t.o power for operating KAU manure pulverizer for basal application of manures in soil directly.

In handling the powdered manure through a blower, air is used as a carrier for dissipation. Pulverized manure is a mixture of fine dust particles which have a very less terminal velocity and settling time. So an experimental setup was developed to study the manure properties and assess the performance parameters of blower. Various types of impellers *viz.*, paddle type impeller, straight 6-blade impeller, straight 4-blade impeller and radial closed impeller were developed following theoretical design standards under standard ASME codes. Variation in suction velocity, air velocity with impeller rpm and variation in discharge at the outlets w.r.to airflow velocity were studied to find out the best performance of an impeller.

Also a 3-way right angle bevel gearbox is designed and developed to achieve different or equal rpms from both the outputs. Although there are a lot of commercially available 3-way right angle gearboxes, they mainly involved gear reduction and the output shafts are opposite to each other. But here in this case a 3-way gearbox with output shafts at right angle to each other are recommended. Here the input power for gearbox is derived from the tractor PTO(540rpm) that is converted into 1000rpm at both outputs (1&2). It consists of 3 spur gears and 2 bevel gears of 1:1 ratio inclined at 90 degree under synchrony-meshed condition.

Results from the laboratory blower model indicated that the performance of the radial impeller was good compared to the other impeller. Hence a radial impeller is preferred over other impellers in the development and evaluation of blower prototype. Changing the impeller input speed at 600,800 and 990 rpm, the suction at the eye was measured. Suction velocity at the inlet was found out to be  $4.79 \text{ m s}^{-1}$  at 600 rpm,  $5.96 \text{ m s}^{-1}$  at 800 rpm and  $7.08 \text{ m s}^{-1}$  at 990 rpm. Variation in air velocity at the individual

outlets is very less and the average of air velocity at the outlets was found to be 4.41 m s<sup>-1</sup> at 600 rpm, 6.0 m s<sup>-1</sup> at 800 rpm and 7.18 m s<sup>-1</sup> at 990 rpm.

Discharge rate of developed prototype with cow dung was found out to be 5.73 kg min<sup>-1</sup> at 600 rpm, 6.54 kg min<sup>-1</sup> at 800 rpm and 7.19 kg min<sup>-1</sup> at 990 rpm, with goat faecal pellets was found out to be 7.03 kg min<sup>-1</sup> at 600 rpm, 8.12 kg min<sup>-1</sup> at 800 rpm and 8.42 kg min<sup>-1</sup> at 990 rpm and with neem cake was found out to be 7.29 kg min<sup>-1</sup> at 600 rpm, 8.10 kg min<sup>-1</sup> at 800 rpm and 8.39 kg min<sup>-1</sup> at 990 rpm with valve in full open condition. In case of valve at half open condition, discharge rate of developed prototype with cow dung was found out to be 3.92 kg min<sup>-1</sup> at 600 rpm, 4.86 kg min<sup>-1</sup> at 800 rpm and 5.73 kg min<sup>-1</sup> at 990 rpm, with goat faecal pellets was found out to be 5.36 kg min<sup>-1</sup> at 600 rpm, 6.46 kg min<sup>-1</sup> at 800 rpm and 6.75 kg min<sup>-1</sup> at 990 rpm and with neem cake was found out to be 5.82 kg min<sup>-1</sup> at 600 rpm, 6.29 kg min<sup>-1</sup> at 800 rpm and 7.03 kg min<sup>-1</sup> at 990 rpm.

In case of valve at full opened condition, coefficient of uniformity at the outlets with cow dung was found to be 4.8 % at 600 rpm, 6.02 % at 800 rpm and 9.66 % at 990 rpm, with goat faecal pellets was found to be 5.57 % at 600 rpm, 7.76 % at 800 rpm and 10.84 % at 990 rpm and with neem cake was found to be 4.58 % at 600 rpm, 6.32 % at 800 rpm and 11.26 % at 990 rpm respectively. In case of valve at half opened condition, coefficient of uniformity at the outlets with cow dung was found to be 3.09 % at 600 rpm, 6.17 % at 800 rpm and 10.13 % at 990 rpm, with goat faecal pellets was found to be 4.49 % at 600 rpm, 6.04 % at 800 rpm and 9.63 % at 990 rpm and with neem cake was found to be 4.03 % at 600 rpm, 6.51 % at 800 rpm and 8.81 % at 990 rpm respectively.

The actual field capacity and efficiency of manure pulverizer cum applicator was found out to be 0.311 ha h<sup>-1</sup> and 86.5 % at a forward speed of 2.0 km h<sup>-1</sup>, 0.356 ha h<sup>-1</sup> and 79.2 % at a forward speed of 2.5 km h<sup>-1</sup> and 0.395 ha h<sup>-1</sup> and 73.1 % at a forward speed of 3.0 km h<sup>-1</sup>. Maximum field capacity was noted at a traveling speed of 3.0 km h<sup>-1</sup>. A larger application rate of 1387.1 kg ha<sup>-1</sup> for cow dung, 1624.4 kg ha<sup>-1</sup> for goat faecal pellets and 1618.6 kg ha<sup>-1</sup> for neem cake was found at an engine rpm of 2500, forward speed of 2 km h<sup>-1</sup> with a field capacity of 0.31 ha h<sup>-1</sup>. With increasing the forward speed to 2.5 and 3.0 km h<sup>-1</sup>, field capacity as well as application rate decreased.

The cost of manure pulverizer cum applicator alone is Rs. 64,000. Cost of operation of manure pulverizer cum applicator as an attachment to tractor as explained in Section 3.4 was found as 583.05 Rs h<sup>-1</sup> and 1943.5 Rs ha<sup>-1</sup>. Cost of manual manure application followed by manure pulverization was 582.7 Rs h<sup>-1</sup> and 4662.2 Rs ha<sup>-1</sup>. The benefit-cost ratio of the developed machine was 1.4:1.



## **CHAPTER VI**

### **SUGGESTIONS FOR FUTURE WORK**

1. Development of standing or sitting provision to labour for regular feeding of manure in the field.
2. Provision for holding unpulverized manure bags on either side of developed unit to make feeding easy.
3. Further modification of valve control mechanism.
4. Intensive field evaluation of the unit has to be done.

# REFERENCES

## REFERENCES

- Abubakar, A.B., Oumarou, M.B., and Oluwole, F.A. 2018. Design and development of a blower for downdraft biomass gasifier. *Arid Zone J. of Eng., Technol. and Environ.* 14(2):292-303.
- Ahmad, M.C. 2016. Development of a Portable Pneumatic Grain Broadcasting Unit. *J. Soil Sci. and Agric. Eng., Mansoura Univ.* 7(8): 587-594.
- Amit, K., Kamal, K.J., Dave, R.K., and Anshul, C. 2017. CFD analysis of centrifugal pump impeller having different exit blade width, exit diameter and trailing edge blade angle to enhance performance. *Int. Res. J. of Eng. and Technol.* 4(05): 1231-1239.
- Anthony, M.C. 2014. Portable direct current Hydroseeder. United States Patent No.2014/0061325 A1. Available: <https://patents.google.com/patent/US20140061325A1/en> [17 November, 2015].
- Beena Devendra, B., Salim Abbasbhai, C., and Sugnam Naga, R.H. 2017. Design, Development and Analysis of Centrifugal Blower. *J. of the Inst. o Eng.* 99(3): 277-284.
- Choudhary, S., Din, M., and Sahu, P. 2016. Characteristics of bioslurry and FYM for mechanized application. *Int. J. of Innovative Res. in Sci., Eng. and Technol.* 5(5): 6734-6738.
- Chowda Reddy, M., Prakash, K.V., Veerangoud, M., and Yarnal, R.S. 2013. Development of animal operated farm yard manure applicator. *Int. J. agric. Eng.* 6(2): 519-523.
- Chunxi, L., Ling, W.S., and Akui, J.Y. 2011. The performance of a centrifugal fan with enlarged impeller. *Energy Convers. and Manag.* 52(9): 902–2910.
- Crivello, A. 2011. Portable Hydroseeder. United States Patent No.2011/0146549 A1. Available: <https://patents.google.com/patent/US20110146549A1/en> [23 June, 2011].

- Davis, J. G. and Meyer, R. B. 1998. Manure spreader calibration. *CSU Cooperative Extension Agriculture*, paper no. 0.561. <http://efotg.sc.egov.usda.gov/references/public/CO/>
- Elizabeth, G., Stuart, G., and Marilyn, T. 2012. Manure effects on soil organisms and soil quality. *Emerging issues in animal agriculture*; 26, November, 2012, Michigan State University Extension. p.1-6.
- Etamaihe, U.J. and Iwe, M.O. 2014. Development and Performance Evaluation of a Reciprocating Motion Cassava Shredder. *The Int. J. of Eng. and Sci.* 3(4): 06-15.
- Glancey, J.L. 1996. Applicator for side dressing row crops with solid waste. *Am. Soc. of Agric. Eng.* 39(3): 829-835.
- Haffer, I. 2009. Contribution of several duster parameters to performance in mechanical date palm pollen delivery. *Appl. Eng. in Agric.* 15(1): 7-10.
- Jain, A.K. and Lawrence, A.K.A. 2015. Performance evaluation of bullock drawn farm yard manure spreader. *Int. Res. J. of Eng. and Technol.* 2(03): 313-316.
- James, K.P. and Roger, A.B. 2000. Powder flowability. *Pharmaceutical Technology*. pp. 60-84.
- Jayan, P.R., Amal, D.J., Arya, K.T., and Harsha, S. 2017. Machine for pulverization of organic manures. *Krishiyankanam*. 23(5): 13-14.
- Jegan, P. and Jerry Vasanth, P. 2017. Performance analysis of vermicompost spreader with a cultivator. *Int. J. of Adv. Eng. and Res. Dev.* 4(4): 770-777.
- Jitendra Kumar, Satish Kumar, Ashok Kumar and Manish Kumar. 2018. Performance evaluation of grinding machine developed for commercial manufacturing of quality vermicompost. *Int. J. of Curr. Microbiol. Appl. Sci.* 7: 4413-4421.
- Jotautiene, E. and Bivainis, V. 2017. Investigations on geometrical particle parameters and aerodynamic features of granular manure fertilizers. *Eng. for Rural Dev.* pp: 1452-1457.

- Julienne, A., Lague, C., Schoenau, J., and Feddas, J. 2010. Effect of manure type, application rate, and application method on odours from manure spreading. *Can. Biosyst. Eng.* 52: 619-629.
- Kepner, R. A., Bainer, R. and Barger, E. L. 2005. *Principles of Farm machinery* (3<sup>rd</sup> Ed.). CBS Publishers & Distributors Pvt. Ltd., New Delhi, 23p.
- KAU (Kerala Agricultural University) 2016. *Package of Practices Recommendations: Crops* (15<sup>th</sup> Ed). Kerala Agricultural University, Thrissur, 360p.
- Ketan, J., and Sunny, R. 2015. Numerical analysis of centrifugal air blower. *Int. J. for Sci. Res. and Dev.* 3(10): 124-127.
- Kothari Kunal, M., Jadhav Saurabh, S., Lodha Mohit, C., and Ghodke Priyanka, G. 2018. Design and Fabrication of Cow-Dung Spreader. *Int. J. for Res. in Eng. Appl. & Manag.* Special Issue – ICRTET: 552-556.
- Kumara, C.D. and Dwivedi, A.K. 2010. Economics of organic farming vis-à-vis conventional farming in India. *Bilingual J. of Humanities and Social Sci.* 1(2).
- Lague, C., Agnew, J.M., Hubert, L., and Roberge, M. 2006. Development of a precision planter for solid and semi-solid manure. *Appl. Eng. in Agric.* 22(3): 345-350.
- Landry, H., Lague, C. and Roberge, M. 2004. Physical and rheological properties of manure products. *Appl. Engg. Agric.* 20(3): 277-288.
- Landry, H., Piron, E., Agnew, J.M., Lague, C., and Roberge, M. 2005. Performances of conveying systems for manure spreaders and effects of hopper geometry on output flow. *Appl. Eng. in Agric.* 21(2): 159–166.
- Lucio, C., Alessandro, C., Giovanni, D., Franco, R., Anthony, G.S., and Paolo, V. 2014. Predicting the performance of an industrial centrifugal fan incorporating cambered plate impeller blades [on-line]. Available: <http://www.pp.bme.hu/me/article/view/7397> [31 Jan.2014].
- Mari G.R. 2000. Performance evaluation of tractor operated manure spreader. *Pakist. J. of Agric., Agric. Eng. Vet. Sci.* 16(1): 45-49.

- Michael, S.B. 2006. Distribution Assembly for Particulate Material. United States Patent No.7080961 B1. Available: <https://patents.google.com/patent/US6883736B1/en> [25 June, 2006].
- Mohan Kumar, M., Adarsha, L.K., Singh, S.P., and Likin Boppana, L. 2017. Economics of Organic Farming over Conventional Farming- A Case Study in Karnataka, India. *Int. J. of Curr. Microbiol. and Appl. Sci.* 6(11): 2810-2817.
- Ozbek, O., Marakoglu, T., and Carman, K. 2010. The effects of a prototype liquid manure spreader machine on nitrogen losses and maize yield. *J. of Agric. Machinery.* 6(2): 85-92.
- Pabitra, K.M. 2011. *Fundamentals of vegetable production: chap. 11. Manure for vegetable production.* Bidhan Chandra Krishi Viswavidyalaya Kalyani, West Bengal, 300p.
- Patil, S.T. and Munde, P.A. 2017. Development of an animal drawn manure spreader cum cart. *Int. J. Agric. Eng.* 10(2): 531-536.
- Patil, S.T. and Munde, P.A. 2017. Performance evaluation of an animal drawn manure spreader cum cart. *Eng. and Technol. in India.* 8(1): 80-92.
- Basavraj, R., Mallikarjun, B., Prasad, N., and Aditya, D. 2018. Design and Fabrication of Fertiliser Spreading Machine. *Int. J. for Res. in Appl. Sci. & Eng. Technol.* 6(7): 238-245.
- Rahul, B., Mahesh, K.N., and Rupinder, C. 2015. Field and economic studies of tractor operated manure spreader with rear vertical rollers- a need based study for organic farming approach in Indian agriculture. *Int. J. of Agric. Sci. and Res.* 5(6): 347-356.
- Reiman, M., Clay, D. E., Carlson, C.G., Clay, S.A., Reicks, G., Clay, D.W., and Humburg, D.E. 2009. Manure placement depth impacts on crop yields and N retained in soil. *J. of Environ. Sci. and Health.* 44: 76–85.
- Rex, R.D. 2000. Method and apparatus for applying agricultural seed or fertilizer mix over the surface of the ground. United States Patent No. USOO6070814A. Available: <https://patents.google.com/patent/US6070814A/en> [6 June, 2000].

- Richard, Tom L. and Hanna, M. 1999. Solid manure application: toward a sophisticated spreader. *Proceedings of the Eleventh annual integrated crop management conference*, 02 December 1999. Integrated Crop Management Conference, pp.79-82.
- Sahay, J. 2015. *Elements of Agricultural Engineering*. Standard Publishers Distributors, New Delhi, 214p.
- Sahay, K.M. and Singh, K.K. 2001. *Unit operations of agricultural processing* (2<sup>nd</sup> Ed.). Vikas Publishing House Pvt Ltd, India, 109p.
- Sani, M.S., Kantiok, O., and Lawal, I.A. 2016. Design of a centrifugal blower for a 400kg rotary furnace. *Am. J. of Eng. Res.* 5(10): 181-186.
- Sapkale, P.R., Mahalle, S.B., and Bastewad, T.B. 2010. Performance evaluation of tractor operated manure spreader. *Int. J. of Agric. Eng.* 3(1): 167-170.
- Singh, J.P. and Thakur, T.C. 2018. Laboratory and field evaluation of subsoiler cum vermicompost and soil amendments applicator. *Int. J. of Agric. Eng.* 1(1): 233-243.
- Singh, R.C. and Singh, C.D. 2014. Design and development of an animal drawn farmyard manure spreader. *Afr. J. of Agric. Res.* 9(44): 3245-3250.
- Suthakar, B., Kathirvel, K., Manian, R., and Manohar, J.D. 2008. Development and Performance Evaluation of Manure Spreading Attachment to Two Wheel Trailer. *Agric mechanization in Asia, Africa and Latin America*. 39.
- Yan, G. and Xi, P. 2010. Study on methods of determining main geometric parameters of centrifugal fan impeller. *Inst. of Electr. and Electr. Eng.* 4: 42-46.
- Yang, S. and Evans, J.R.G. 2007. Metering and dispensing studies on powders and free flowing techniques. *Powder Technology*. 178: 56-72.
- Reddy, T.Y. and Reddy, G.H.S. 2017. *Principles of Agronomy* (5<sup>th</sup> Ed.). Kalyani publishers, New Delhi, 203p.

# APPENDICES



## APPENDIX I(A)

## Bulk density of manures

Cow dung						
Mass of beaker, g	Mass of beaker + sample, gm	Mass of sample, gm	Height of beaker, cm	Internal diameter, cm	Volume, cm <sup>3</sup>	Bulk density, g cm <sup>-3</sup>
58.6	79.6	21	7	4.5	111.33	0.189
58.6	80.8	22.2	7	4.5	111.33	0.199
58.6	80.4	21.8	7	4.5	111.33	0.196
Goat faecal pellets						
58.6	113.2	54.6	7	4.5	111.33	0.490
58.6	112	53.4	7	4.5	111.33	0.480
58.6	114.8	56.2	7	4.5	111.33	0.505
Neem cake						
58.6	116.4	57.8	7	4.5	111.33	0.519
58.6	116.2	57.6	7	4.5	111.33	0.517
58.6	116.8	58.2	7	4.5	111.33	0.523

**Sample calculation:**

Mass of beaker, g	=	58.6
Mass of beaker+sample, g	=	79.6
Mass of sample, g	=	21
Height of beaker, cm	=	7
Internal diameter, cm	=	4.5
Volume, cm <sup>-3</sup>	=	111.33
Bulk density of manure, g cm <sup>-3</sup>	=	0.189

**APPENDIX I(B)****Tapped density of manures**

<b>Cow dung</b>						
<b>Mass of beaker, g</b>	<b>Mass of beaker + sample, g</b>	<b>Tapped mass of sample, g</b>	<b>Sample height in beaker, cm</b>	<b>Internal diameter, cm</b>	<b>Volume, cm<sup>3</sup></b>	<b>Bulk density, g cm<sup>-3</sup></b>
58.6	78.8	20.2	4.3	4.5	68.39	0.295
58.6	80.6	22	4.4	4.5	69.98	0.314
58.6	80.8	22.2	4.4	4.5	69.98	0.317
<b>Goat faecal pellets</b>						
58.6	118.2	59.4	5.1	4.5	81.11	0.732
58.6	117.2	58.4	5.5	4.5	87.47	0.668
58.6	118.4	59.8	6.2	4.5	98.61	0.606
<b>Neem cake</b>						
58.6	118.6	60	5.1	4.5	81.11	0.740
58.6	120	61.4	5.2	4.5	82.70	0.742
58.6	118	59.4	4.9	4.5	77.93	0.762

**Sample calculation:**

Mass of beaker, g	=	58.6
Mass of beaker+sample, g	=	78.8
Mass of sample, g	=	20.2
Height of beaker, cm	=	4.3
Internal diameter, cm	=	4.5
Volume, cm <sup>-3</sup>	=	68.39
Bulk density of manure, g cm <sup>-3</sup>	=	0.295

**APPENDIX II****Moisture content of manures**

<b>Cow dung</b>				
Mass of container, g	Initial mass of manure (W <sub>1</sub> ), g	Mass of container + manure sample, g	Mass of container + dried manure, g	Moisture content in dry basis, %
7.8	5	12.8	12.0	19.04
8.0	5	13.0	12.2	19.04
8.2	5	13.2	12.4	19.04
<b>Goat faecal pellets</b>				
14.6	5	19.6	18.8	19.04
14.2	5	19.2	18.4	19.04
13.8	5	18.8	18.0	19.04
<b>Neem cake</b>				
14.8	5	19.8	19.0	19.04
14.4	5	19.4	18.3	19.04
14.4	5	19.4	18.4	25.00

**Sample calculation:**

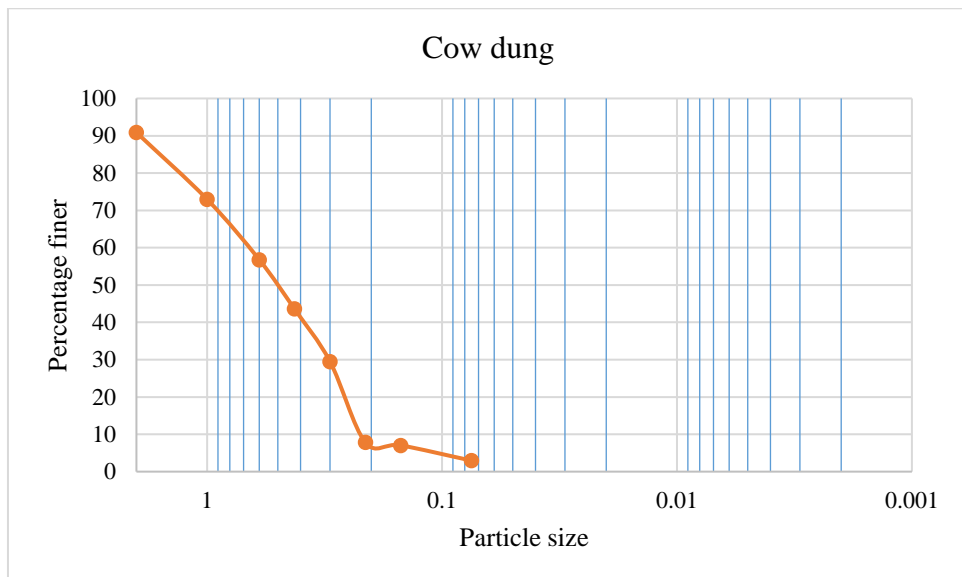
Mass of container, g	=	7.8
Initial mass of manure (W <sub>1</sub> ), g	=	5.0
Mass of container + manure sample, g	=	12.8
Mass of container + dried sample, g	=	12.0
Final mass of sample (W <sub>2</sub> ), g	=	4.2
Moisture content, %	=	$\frac{W_1 - W_2}{W_2}$
	=	19.04 %

### APPENDIX III(A)

#### Particle size distribution of manure

Total mass of the sample, g = 250

Cow dung					
Sl. No.	IS sieve size, $\mu\text{m}$	Mass of manure retained, g	% retained	Cumulative % retained	Cumulative % finer
1	2 mm	22.8	9.12	9.12	90.88
2	1 mm	44.8	17.92	27.04	72.96
3	600	40.4	16.16	43.20	56.80
4	425	33.0	13.20	56.40	43.60
5	300	35.2	14.08	70.48	29.52
6	212	55.2	21.68	92.16	7.84
7	150	2.0	0.80	92.96	7.04
8	75	10.2	4.08	97.04	2.96
9	Retainer	6.4	2.56	99.60	0.40

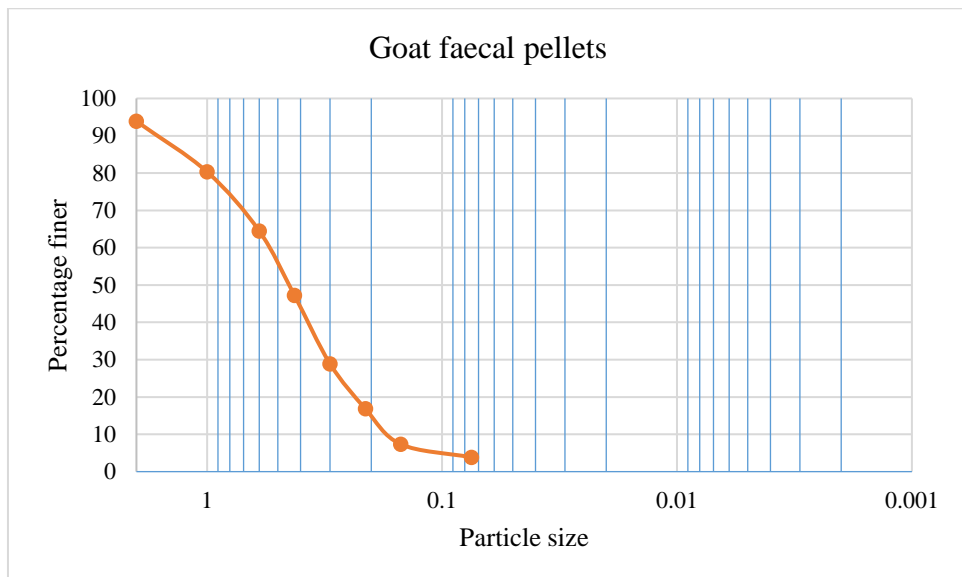


### APPENDIX III(B)

#### Particle size distribution of manure

Total mass of the sample, g = 250

Goat faecal pellets					
Sl. No.	IS sieve size, $\mu\text{m}$	Mass of manure retained, g	% retained	Cumulative % retained	Cumulative % finer
1	2 mm	15.3	6.12	6.12	93.88
2	1 mm	33.9	13.56	19.68	80.32
3	600	39.6	15.84	35.52	64.48
4	425	43.1	17.24	52.76	47.24
5	300	45.8	18.32	71.08	28.92
6	212	30.2	12.08	83.16	16.84
7	150	23.7	9.48	92.64	7.36
8	75	8.8	3.52	96.16	3.84
9	Retainer	7.6	3.04	99.2	0.8

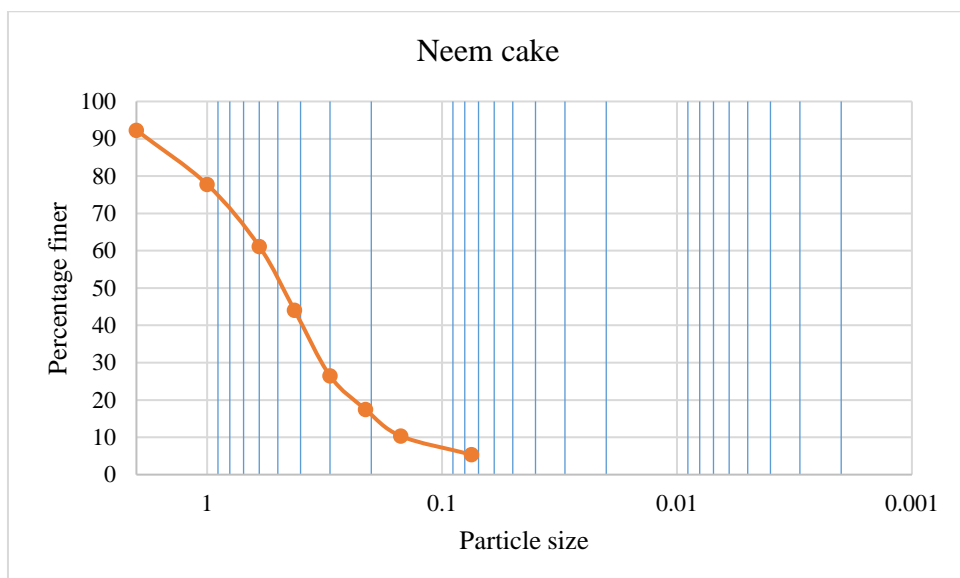


### APPENDIX III(C)

#### Particle size distribution of manure

Total mass of the sample, g = 250

Neem cake					
Sl. No.	IS sieve size, $\mu\text{m}$	Mass of manure retained, g	% retained	Cumulative % retained	Cumulative % finer
1	2 mm	19.3	7.72	7.72	92.28
2	1 mm	36.3	14.52	22.24	77.76
3	600	41.5	16.6	38.84	61.16
4	425	42.7	17.08	55.92	44.08
5	300	44	17.6	73.52	26.48
6	212	22.4	8.96	82.48	17.52
7	150	17.9	7.16	89.64	10.36
8	75	12.5	5	94.64	5.36
9	Retainer	11.2	4.48	99.12	0.88



## APPENDIX IV

### Testing of laboratory blower model

#### Variation of suction velocities at the blower inlet (at the eye)

Sl. No.	Type of impeller	Air velocity, m s <sup>-1</sup>		
		Frequency, Hz		
		30	40	50
1	Paddle type impeller	3.90	4.90	6.10
		3.85	4.80	6.05
		3.92	4.95	6.12
2	Straight 6-blade impeller	4.40	5.90	7.60
		4.35	5.86	7.58
		4.42	5.90	7.63
3	Straight 4-blade impeller	4.60	5.70	7.80
		4.56	5.64	7.76
		4.63	5.76	7.82
4	Radial impeller	4.30	5.90	8.00
		4.23	5.86	8.01
		4.30	5.92	7.92

#### Analysis of variance for variation of suction velocities at the blower inlet (at the eye)

Source of Variation	SS	df	MS	F	P-value	F crit
Sample	7.60	3	2.53	1403	4.4E-27	3.01
Columns	57.27	2	28.64	15850	3.5E-38	3.40
Interaction	1.98	6	0.33	183	8.0E-19	2.51
Within	0.04	24	0.00			
Total	66.90	35				

## APPENDIX V

## Variation in air velocity of various impellers at 30,40 and 50 Hz

<b>Paddle type impeller</b>				
<b>Frequency, Hz</b>	<b>Suction at the eye, m s<sup>-1</sup></b>	<b>Air velocity at outlets, m s<sup>-1</sup></b>		
		<b>1</b>	<b>2</b>	<b>3</b>
30	3.9	4.7	4.7	4.7
40	4.9-5.2	6.7	6.7	6.9
50	6.0-6.1	8.0	8.7	8.2
<b>Straight 6-blade impeller</b>				
<b>Frequency, Hz</b>	<b>Suction at the eye, m s<sup>-1</sup></b>	<b>Air velocity at outlets, m s<sup>-1</sup></b>		
		<b>1</b>	<b>2</b>	<b>3</b>
30	4-4.4	4.7	4.9	4.9
40	5.8-5.9	6.3	6.3	6.1
50	7.6	8.4	8.6	8.2
<b>Straight 4-blade impeller</b>				
<b>Frequency, Hz</b>	<b>Suction at the eye, m s<sup>-1</sup></b>	<b>Air velocity at outlets, m s<sup>-1</sup></b>		
		<b>1</b>	<b>2</b>	<b>3</b>
30	4.6	4.7	4.7	4.7
40	5.6-5.7	5.8	5.9	6.2
50	7.5-7.8	7.1	7.8	7.8
<b>Radial impeller</b>				
<b>Frequency, Hz</b>	<b>Suction at the eye, m s<sup>-1</sup></b>	<b>Air velocity at outlets, m s<sup>-1</sup></b>		
		<b>1</b>	<b>2</b>	<b>3</b>
30	4.2-4.3	4.1	4.3	4.2
40	6.2-5.9	5.6	5.7	5.6
50	7.8-8.0	6.9	7	6.9



## APPENDIX VI

## Coefficient of variation in discharge at 3 outlets of blower

<b>Paddle type impeller</b>					
<b>Frequency, Hz</b>	<b>Input, kg</b>	<b>Discharge at outlets, kg</b>			<b>CV, %</b>
		<b>1</b>	<b>2</b>	<b>3</b>	
30	3	0.82	1.12	1.05	15.8
40	3	0.89	1.11	1.00	11.0
50	3	0.77	1.28	0.94	26.1
<b>Straight 6-blade impeller</b>					
<b>Frequency, Hz</b>	<b>Input, kg</b>	<b>Discharge at outlets, kg</b>			<b>CV, %</b>
		<b>1</b>	<b>2</b>	<b>3</b>	
30	3	0.85	1.10	1.05	13.2
40	3	0.90	1.05	1.00	7.8
50	3	0.65	1.20	1.15	30.4
<b>Straight 4-blade impeller</b>					
<b>Frequency, Hz</b>	<b>Input, kg</b>	<b>Discharge at outlets, kg</b>			<b>CV, %</b>
		<b>1</b>	<b>2</b>	<b>3</b>	
30	3	0.85	1.25	0.90	21.8
40	3	0.86	1.12	1.02	13.1
50	3	0.70	1.20	1.10	26.5
<b>Radial impeller</b>					
<b>Frequency, Hz</b>	<b>Input, kg</b>	<b>Discharge at outlets, kg</b>			<b>CV, %</b>
		<b>1</b>	<b>2</b>	<b>3</b>	
30	3	0.89	1.10	1.01	10.5
40	3	0.90	1.10	1.00	10.0
50	3	0.60	1.25	1.15	35.0

## APPENDIX VII

### Variation in discharge rate of various impellers at 30,40 and 50 Hz with goat faecal pellets

#### Paddle type impeller

Frequency	RPM of the impeller	Air velocity, $\text{m s}^{-1}$	Input feed, kg	Time taken to feed, min	Discharge rate, $\text{kg min}^{-1}$
30 Hz	890-900	4.7	3	1.29	2.33
			3	1.25	2.4
			3	1.27	2.36
40 Hz	1190-1200	6.8	3	1.18	2.54
			3	1.13	2.65
			3	1.1	2.73
50 Hz	1470-1490	8.3	3	1.02	2.94
			3	1.01	2.97
			3	1.03	2.91

#### Analysis of variance for variation in discharge rate for paddle type impeller

Source of Variation	SS	df	MS	F	P-value	F crit
Sample	0.080	2	0.040	18	0.000241	3.89
Columns	10.200	1	10.200	4579	7.21E-17	4.75
Interaction	0.513	2	0.256	115	1.48E-08	3.89
Within	0.027	12	0.002			
Total	10.820	17				

### Straight 6-blade impeller

Frequency	RPM of the impeller	Air velocity, $\text{m s}^{-1}$	Input feed, kg	Time taken to feed, min	Discharge rate, $\text{kg min}^{-1}$
30 Hz	890-900	4.8	3	1.16	2.59
			3	1.13	2.65
			3	1.18	2.54
40 Hz	1190-1200	6.2	3	1.05	2.86
			3	1.03	2.9
			3	1.06	2.81
50 Hz	1470-1490	8.4	3	0.88	3.33
			3	0.91	3.27
			3	0.9	3.33

### Analysis of variance for variation in discharge rate for straight 6-blade impeller

Source of Variation	SS	df	MS	F	P-value	F crit
Sample	0.162	2	0.081	66	3.35E-07	3.89
Columns	16.018	1	16.018	13046	1.36E-19	4.75
Interaction	0.729	2	0.364	297	6.06E-11	3.89
Within	0.015	12	0.001			
Total	16.923	17				

### Straight 4-blade impeller

Frequency	RPM of the impeller	Air velocity, $\text{m s}^{-1}$	Input feed, kg	Time taken to feed, min	Discharge rate, $\text{kg min}^{-1}$
30 Hz	890-900	4.7	3	1.23	2.44
			3	1.21	2.48
			3	1.18	2.54
40 Hz	1190-1200	6	3	1.1	2.73
			3	1.03	2.91
			3	1.06	2.83
50 Hz	1470-1490	7.6	3	0.91	3.27
			3	0.95	3.16
			3	0.9	3.33

### Analysis of variance for variation in discharge rate for straight 4-blade impeller

Source of Variation	SS	df	MS	F	P-value	F crit
Sample	0.175	2	0.087	25	4.868E-05	3.89
Columns	14.436	1	14.436	4191	1.223E-16	4.75
Interaction	0.834	2	0.417	121	1.106E-08	3.89
Within	0.041	12	0.003			
Total	15.487	17				

**Radial impeller**

Frequency	RPM of the impeller	Air velocity, $\text{m s}^{-1}$	Input feed, kg	Time taken to feed, min	Discharge rate, $\text{kg min}^{-1}$
30 Hz	890-900	4.2	3	1.13	2.65
			3	1.1	2.73
			3	1.15	2.61
40 Hz	1190-1200	5.6	3	1.01	2.97
			3	1	3
			3	1.03	2.91
50 Hz	1470-1490	6.9	3	0.9	3.33
			3	0.93	3.23
			3	0.86	3.49

**Analysis of variance for variation in discharge rate for radial impeller**

Source of Variation	SS	df	MS	F	P-value	F crit
Sample	0.158	2	0.079	19	0.0001952	3.89
Columns	17.622	1	17.622	4207	1.196E-16	4.75
Interaction	0.633	2	0.316	76	1.592E-07	3.89
Within	0.050	12	0.004			
Total	18.463	17				

## APPENDIX VIII

## Variation in gearbox output speeds due to variation in engine rpm

Sl. No.	Engine rpm	P.T.O. speed	Pulley dia at pulverizer input	Blade rpm	Impeller rpm
1	1500	320	3 ½	533	600
			4	600	600
			5	762	600
			6	914	600
2	2000	430	3 ½	711	800
			4	800	800
			5	1016	800
			6	1219	800
3	2500	540	3 ½	880	990
			4	990	990
			5	1240	990
			6	1480	990

**APPENDIX IX**

**Laboratory evaluation of prototype manure pulverizer cum applicator  
Variation in air velocity at blower outlets due to variation in engine rpm**

Sl. No.	Impeller speed	Suction at the eye	Air velocity		
			1	2	3
1	600	4.8	4.5	4.6	4.5
			4.35	4.5	4.4
			4.5	4.6	4.45
2	800	6	6.1	5.8	6
			6.05	5.95	6
			6.1	5.9	5.9
3	990	7.1	7.6	7.1	7.2
			7.45	7	7.1
			7.5	7.2	7.1

**Analysis of variance for variation in air velocities at blower outlets**

Source of Variation	SS	df	MS	F	P-value	F crit
Sample	34.377	2	17.189	3640	3.38E-24	3.55
Columns	0.167	2	0.083	18	5.72E-05	3.55
Interaction	0.243	4	0.061	13	4.07E-05	2.93
Within	0.085	18	0.005			
Total	34.872	26				

## APPENDIX X

**Coefficient of uniformity at discharge outlets w.r.to blower rpm (Valve at full open condition)**

Sl. No.	Blower rpm	Cow dung			CU, %
		1	2	3	
1	600	1.93	1.99	1.81	4.8
2	800	2.61	2.32	2.06	6.02
3	990	2.46	2.59	2.14	9.66
	Blower rpm	Goat fecal pellets			CU, %
		1	2	3	
1	600	2.33	2.48	2.22	5.57
2	800	2.7	2.92	2.5	7.76
3	990	2.7	3.15	2.57	10.84
	Blower rpm	Neem cake			CU, %
		1	2	3	
1	600	2.41	2.55	2.33	4.58
2	800	2.65	2.89	2.56	6.32
3	990	2.8	3.11	2.48	11.26



## APPENDIX XI

**Coefficient of uniformity at discharge outlets w.r.to blower rpm (Valve at half open condition)**

Sl. No.	Blower rpm	Cow dung			CU, %
		1	2	3	
1	600	1.3	1.35	1.27	3.09
2	800	1.52	1.72	1.62	6.17
3	990	1.87	2.17	1.69	10.13
	Blower rpm	Goat faecal pellets			CU, %
		1	2	3	
1	600	1.78	1.87	1.71	4.49
2	800	2.16	2.28	2.02	6.04
3	990	2.22	2.48	2.05	9.63
	Blower rpm	Neem cake			CU, %
		1	2	3	
1	600	1.9	2.03	1.89	4.03
2	800	2.12	2.22	1.95	6.51
3	990	2.25	2.58	2.2	8.81

## APPENDIX XII

Discharge rate of manure w.r.to blower rpm (Valve at full open condition)

Blower rpm	Cow dung			Discharge rate	
	1	2	3	kg min <sup>-1</sup>	kg h <sup>-1</sup>
600	1.93	1.99	1.81	5.73	343.8
800	2.61	2.32	2.06	6.99	419.4
990	2.46	2.59	2.14	7.19	431.4
Blower rpm	Goat faecal pellets			Discharge rate	
	1	2	3	kg min <sup>-1</sup>	kg h <sup>-1</sup>
600	2.33	2.48	2.22	7.03	421.8
800	2.70	2.92	2.50	8.12	487.2
990	2.70	3.15	2.57	8.42	505.2
Blower rpm	Neem cake			Discharge rate	
	1	2	3	kg min <sup>-1</sup>	kg h <sup>-1</sup>
600	2.41	2.55	2.33	7.29	437.4
800	2.65	2.89	2.56	8.10	486
990	2.80	3.11	2.48	8.39	503.4

## APPENDIX XIII

**Discharge rate of manure w.r.to blower rpm (Valve at half open condition)**

<b>Blower rpm</b>	<b>Cow dung</b>			<b>Discharge</b>	
	<b>1</b>	<b>2</b>	<b>3</b>	<b>kg min<sup>-1</sup></b>	<b>kg h<sup>-1</sup></b>
600	1.3	1.35	1.27	3.92	235.2
800	1.52	1.72	1.62	4.86	291.6
990	1.87	2.17	1.69	5.73	343.8
<b>Blower rpm</b>	<b>Goat fecal pellets</b>			<b>Discharge</b>	
	<b>1</b>	<b>2</b>	<b>3</b>	<b>kg min<sup>-1</sup></b>	<b>kg h<sup>-1</sup></b>
600	1.78	1.87	1.71	5.36	321.6
800	2.16	2.28	2.02	6.46	387.6
990	2.22	2.48	2.05	6.75	405
<b>Blower rpm</b>	<b>Neem cake</b>			<b>Discharge</b>	
	<b>1</b>	<b>2</b>	<b>3</b>	<b>kg min<sup>-1</sup></b>	<b>kg h<sup>-1</sup></b>
600	1.9	2.03	1.89	5.82	349.2
800	2.12	2.22	1.95	6.29	377.4
990	2.25	2.58	2.2	7.03	421.8

## APPENDIX XIV

## Field capacity and field efficiency

Speed, kmph	T.F.C, ha h <sup>-1</sup>	A.F.C, ha h <sup>-1</sup>	Efficiency, %
2.0	0.36	0.315	87.5
2.0	0.36	0.307	85.3
2.0	0.36	0.312	86.7
2.5	0.45	0.352	78.2
2.5	0.45	0.361	80.2
2.5	0.45	0.356	79.1
3.0	0.54	0.402	74.4
3.0	0.54	0.393	72.8
3.0	0.54	0.389	72.0

**Calculation:**

$$\begin{aligned}
 \text{Total area covered, ha} &= 0.12 \\
 \text{Total time taken, h} &= 0.38 \\
 \text{Actual field capacity, ha h}^{-1} &= \frac{0.12}{0.38} \\
 &= 0.315 \\
 \text{Width of operation, m} &= 1.8 \\
 \text{Speed of operation, kmph} &= 2.0 \\
 \text{Theoretical field capacity, ha h}^{-1} &= \frac{1.8 \times 2000}{10000} \\
 &= 0.36 \\
 \text{Field efficiency, \%} &= \frac{\text{A.F.C}}{\text{T.F.C}} \times 100 \\
 &= 87.5
 \end{aligned}$$

## APPENDIX XV

**Application rate of different types of manures(T), for selected operational speeds(S) of tractor, at selected level of valve opening(V) and engine rpm(E) under performance evaluation of manure pulverizer cum applicator**

**T<sub>1</sub>,T<sub>2</sub>,T<sub>3</sub> = Cow dung, goat faecal pellets, neem cake**

**S<sub>1</sub>,S<sub>2</sub>,S<sub>3</sub> = Operational speed of tractor viz., 2.0, 2.5 and 3.0 km h<sup>-1</sup>**

**V<sub>1</sub>,V<sub>2</sub> = Valve full and half open condition**

**E<sub>1</sub>,E<sub>2</sub>,E<sub>3</sub> = Engine rpm/blower speed viz., 1500, 2000 and 2500 rpm**

Sl. No.	Treatments	Application rate of manure, kg ha <sup>-1</sup>
1	T <sub>1</sub> S <sub>1</sub> V <sub>1</sub> E <sub>1</sub> R <sub>1</sub>	1104.3
2	T <sub>1</sub> S <sub>1</sub> V <sub>1</sub> E <sub>1</sub> R <sub>2</sub>	1106.1
3	T <sub>1</sub> S <sub>1</sub> V <sub>1</sub> E <sub>1</sub> R <sub>3</sub>	1107.4
Mean		1105.9
4	T <sub>1</sub> S <sub>1</sub> V <sub>1</sub> E <sub>2</sub> R <sub>1</sub>	1263.7
5	T <sub>1</sub> S <sub>1</sub> V <sub>1</sub> E <sub>2</sub> R <sub>2</sub>	1260.2
6	T <sub>1</sub> S <sub>1</sub> V <sub>1</sub> E <sub>2</sub> R <sub>3</sub>	1262.7
Mean		1262.2
7	T <sub>1</sub> S <sub>1</sub> V <sub>1</sub> E <sub>3</sub> R <sub>1</sub>	1389.1
8	T <sub>1</sub> S <sub>1</sub> V <sub>1</sub> E <sub>3</sub> R <sub>2</sub>	1385.6
9	T <sub>1</sub> S <sub>1</sub> V <sub>1</sub> E <sub>3</sub> R <sub>3</sub>	1388.1
Mean		1387.6
10	T <sub>1</sub> S <sub>1</sub> V <sub>2</sub> E <sub>1</sub> R <sub>1</sub>	756.3
11	T <sub>1</sub> S <sub>1</sub> V <sub>2</sub> E <sub>1</sub> R <sub>2</sub>	758.1
12	T <sub>1</sub> S <sub>1</sub> V <sub>2</sub> E <sub>1</sub> R <sub>3</sub>	755.9
Mean		756.8
13	T <sub>1</sub> S <sub>1</sub> V <sub>2</sub> E <sub>2</sub> R <sub>1</sub>	937.6
14	T <sub>1</sub> S <sub>1</sub> V <sub>2</sub> E <sub>2</sub> R <sub>2</sub>	938.9
15	T <sub>1</sub> S <sub>1</sub> V <sub>2</sub> E <sub>2</sub> R <sub>3</sub>	936.6
Mean		937.7
16	T <sub>1</sub> S <sub>1</sub> V <sub>2</sub> E <sub>3</sub> R <sub>1</sub>	1105.5
17	T <sub>1</sub> S <sub>1</sub> V <sub>2</sub> E <sub>3</sub> R <sub>2</sub>	1107.1
18	T <sub>1</sub> S <sub>1</sub> V <sub>2</sub> E <sub>3</sub> R <sub>3</sub>	1104.9

Mean		1105.8
19	$T_1S_2V_1E_1R_1$	965.7
20	$T_1S_2V_1E_1R_2$	966.5
21	$T_1S_2V_1E_1R_3$	964.2
Mean		965.5
22	$T_1S_2V_1E_2R_1$	1102.2
23	$T_1S_2V_1E_2R_2$	1103.5
24	$T_1S_2V_1E_2R_3$	1101.6
Mean		1102.4
25	$T_1S_2V_1E_3R_1$	1211.8
26	$T_1S_2V_1E_3R_2$	1212.5
27	$T_1S_2V_1E_3R_3$	1210.5
Mean		1211.6
28	$T_1S_2V_2E_1R_1$	660.7
29	$T_1S_2V_2E_1R_2$	661.7
30	$T_1S_2V_2E_1R_3$	659.6
Mean		660.7
31	$T_1S_2V_2E_2R_1$	819.1
32	$T_1S_2V_2E_2R_2$	820.3
33	$T_1S_2V_2E_2R_3$	818.9
Mean		819.4
34	$T_1S_2V_2E_3R_1$	965.7
35	$T_1S_2V_2E_3R_2$	964.3
36	$T_1S_2V_2E_3R_3$	966.0
Mean		965.3
37	$T_1S_3V_1E_1R_1$	870.4
38	$T_1S_3V_1E_1R_2$	871.5
39	$T_1S_3V_1E_1R_3$	870.1
Mean		870.7
40	$T_1S_3V_1E_2R_1$	993.4
41	$T_1S_3V_1E_2R_2$	994.6
42	$T_1S_3V_1E_2R_3$	992.5
Mean		993.5
43	$T_1S_3V_1E_3R_1$	1092.2
44	$T_1S_3V_1E_3R_2$	1091.6
45	$T_1S_3V_1E_3R_3$	1092.8
Mean		1092.2

46	T <sub>1</sub> S <sub>3</sub> V <sub>2</sub> E <sub>1</sub> R <sub>1</sub>	595.4
47	T <sub>1</sub> S <sub>3</sub> V <sub>2</sub> E <sub>1</sub> R <sub>2</sub>	596.5
48	T <sub>1</sub> S <sub>3</sub> V <sub>2</sub> E <sub>1</sub> R <sub>3</sub>	594.2
Mean		595.4
49	T <sub>1</sub> S <sub>3</sub> V <sub>2</sub> E <sub>2</sub> R <sub>1</sub>	738.2
50	T <sub>1</sub> S <sub>3</sub> V <sub>2</sub> E <sub>2</sub> R <sub>2</sub>	739.4
51	T <sub>1</sub> S <sub>3</sub> V <sub>2</sub> E <sub>2</sub> R <sub>3</sub>	737.5
Mean		738.4
52	T <sub>1</sub> S <sub>3</sub> V <sub>2</sub> E <sub>3</sub> R <sub>1</sub>	870.4
53	T <sub>1</sub> S <sub>3</sub> V <sub>2</sub> E <sub>3</sub> R <sub>2</sub>	869.6
54	T <sub>1</sub> S <sub>3</sub> V <sub>2</sub> E <sub>3</sub> R <sub>3</sub>	871.5
Mean		870.5
55	T <sub>2</sub> S <sub>1</sub> V <sub>1</sub> E <sub>1</sub> R <sub>1</sub>	1356.3
56	T <sub>2</sub> S <sub>1</sub> V <sub>1</sub> E <sub>1</sub> R <sub>2</sub>	1357.3
57	T <sub>2</sub> S <sub>1</sub> V <sub>1</sub> E <sub>1</sub> R <sub>3</sub>	1355.4
Mean		1356.3
58	T <sub>2</sub> S <sub>1</sub> V <sub>1</sub> E <sub>2</sub> R <sub>1</sub>	1566.6
59	T <sub>2</sub> S <sub>1</sub> V <sub>1</sub> E <sub>2</sub> R <sub>2</sub>	1567.8
60	T <sub>2</sub> S <sub>1</sub> V <sub>1</sub> E <sub>2</sub> R <sub>3</sub>	1565.3
Mean		1566.6
61	T <sub>2</sub> S <sub>1</sub> V <sub>1</sub> E <sub>3</sub> R <sub>1</sub>	1624.4
62	T <sub>2</sub> S <sub>1</sub> V <sub>1</sub> E <sub>3</sub> R <sub>2</sub>	1625.5
63	T <sub>2</sub> S <sub>1</sub> V <sub>1</sub> E <sub>3</sub> R <sub>3</sub>	1623.8
Mean		1624.6
64	T <sub>2</sub> S <sub>1</sub> V <sub>2</sub> E <sub>1</sub> R <sub>1</sub>	1034.1
65	T <sub>2</sub> S <sub>1</sub> V <sub>2</sub> E <sub>1</sub> R <sub>2</sub>	1035.6
66	T <sub>2</sub> S <sub>1</sub> V <sub>2</sub> E <sub>1</sub> R <sub>3</sub>	1033.5
Mean		1034.4
67	T <sub>2</sub> S <sub>1</sub> V <sub>2</sub> E <sub>2</sub> R <sub>1</sub>	1246.3
68	T <sub>2</sub> S <sub>1</sub> V <sub>2</sub> E <sub>2</sub> R <sub>2</sub>	1245.5
69	T <sub>2</sub> S <sub>1</sub> V <sub>2</sub> E <sub>2</sub> R <sub>3</sub>	1247.1
Mean		1246.3
70	T <sub>2</sub> S <sub>1</sub> V <sub>2</sub> E <sub>3</sub> R <sub>1</sub>	1302.3
71	T <sub>2</sub> S <sub>1</sub> V <sub>2</sub> E <sub>3</sub> R <sub>2</sub>	1303.4
72	T <sub>2</sub> S <sub>1</sub> V <sub>2</sub> E <sub>3</sub> R <sub>3</sub>	1301.5
Mean		1302.4

73	$T_2S_2V_1E_1R_1$	1184.8
74	$T_2S_2V_1E_1R_2$	1185.3
75	$T_2S_2V_1E_1R_3$	1184.1
Mean		1184.7
76	$T_2S_2V_1E_2R_1$	1368.5
77	$T_2S_2V_1E_2R_2$	1367.1
78	$T_2S_2V_1E_2R_3$	1369.2
Mean		1368.3
79	$T_2S_2V_1E_3R_1$	1419.1
80	$T_2S_2V_1E_3R_2$	1418.3
81	$T_2S_2V_1E_3R_3$	1417.5
Mean		1418.3
82	$T_2S_2V_2E_1R_1$	903.4
83	$T_2S_2V_2E_1R_2$	904.1
84	$T_2S_2V_2E_1R_3$	905.2
Mean		904.2
85	$T_2S_2V_2E_2R_1$	1088.8
86	$T_2S_2V_2E_2R_2$	1087.6
87	$T_2S_2V_2E_2R_3$	1089.2
Mean		1088.5
88	$T_2S_2V_2E_3R_1$	1137.6
89	$T_2S_2V_2E_3R_2$	1136.2
90	$T_2S_2V_2E_3R_3$	1138.5
Mean		1137.4
91	$T_2S_3V_1E_1R_1$	1067.8
92	$T_2S_3V_1E_1R_2$	1066.2
93	$T_2S_3V_1E_1R_3$	1068.1
Mean		1067.4
94	$T_2S_3V_1E_2R_1$	1233.4
95	$T_2S_3V_1E_2R_2$	1234.8
96	$T_2S_3V_1E_2R_3$	1232.5
Mean		1233.6
97	$T_2S_3V_1E_3R_1$	1279.0
98	$T_2S_3V_1E_3R_2$	1278.3
99	$T_2S_3V_1E_3R_3$	1280.0
Mean		1279.1



100	$T_2S_3V_2E_1R_1$	814.2
101	$T_2S_3V_2E_1R_2$	813.5
102	$T_2S_3V_2E_1R_3$	815.1
Mean		814.3
103	$T_2S_3V_2E_2R_1$	981.3
104	$T_2S_3V_2E_2R_2$	981.6
105	$T_2S_3V_2E_2R_3$	982.5
Mean		981.8
106	$T_2S_3V_2E_3R_1$	1026.0
107	$T_2S_3V_2E_3R_2$	1024.1
108	$T_2S_3V_2E_3R_3$	1026.5
Mean		1025.5
109	$T_3S_1V_1E_1R_1$	1406.4
110	$T_3S_1V_1E_1R_2$	1405.5
111	$T_3S_1V_1E_1R_3$	1407.0
Mean		1406.3
112	$T_3S_1V_1E_2R_1$	1562.7
113	$T_3S_1V_1E_2R_2$	1563.5
114	$T_3S_1V_1E_2R_3$	1564.2
Mean		1563.5
115	$T_3S_1V_1E_3R_1$	1618.6
116	$T_3S_1V_1E_3R_2$	1617.5
117	$T_3S_1V_1E_3R_3$	1619.2
Mean		1618.4
118	$T_3S_1V_2E_1R_1$	1122.8
119	$T_3S_1V_2E_1R_2$	1123.4
120	$T_3S_1V_2E_1R_3$	1121.6
Mean		1122.6
121	$T_3S_1V_2E_2R_1$	1213.5
122	$T_3S_1V_2E_2R_2$	1214.4
123	$T_3S_1V_2E_2R_3$	1215.2
Mean		1214.4
124	$T_3S_1V_2E_3R_1$	1356.3
125	$T_3S_1V_2E_3R_2$	1355.8
126	$T_3S_1V_2E_3R_3$	1354.2
Mean		1355.4

127	$T_3S_2V_1E_1R_1$	1228.7
128	$T_3S_2V_1E_1R_2$	1229.3
129	$T_3S_2V_1E_1R_3$	1227.6
Mean		1228.5
130	$T_3S_2V_1E_2R_1$	1365.2
131	$T_3S_2V_1E_2R_2$	1364.8
132	$T_3S_2V_1E_2R_3$	1363.5
Mean		1364.5
133	$T_3S_2V_1E_3R_1$	1414.0
134	$T_3S_2V_1E_3R_2$	1415.6
135	$T_3S_2V_1E_3R_3$	1413.4
Mean		1414.3
136	$T_3S_2V_2E_1R_1$	980.9
137	$T_3S_2V_2E_1R_2$	981.6
138	$T_3S_2V_2E_1R_3$	979.5
Mean		980.7
139	$T_3S_2V_2E_2R_1$	1060.1
140	$T_3S_2V_2E_2R_2$	1061.5
141	$T_3S_2V_2E_2R_3$	1059.3
Mean		1060.3
142	$T_3S_2V_2E_3R_1$	1184.8
143	$T_3S_2V_2E_3R_2$	1183.5
144	$T_3S_2V_2E_3R_3$	1185.6
Mean		1184.6
145	$T_3S_3V_1E_1R_1$	1107.3
146	$T_3S_3V_1E_1R_2$	1106.8
147	$T_3S_3V_1E_1R_3$	1105.4
Mean		1106.5
148	$T_3S_3V_1E_2R_1$	1230.4
149	$T_3S_3V_1E_2R_2$	1231.5
150	$T_3S_3V_1E_2R_3$	1229.6
Mean		1230.5
151	$T_3S_3V_1E_3R_1$	1274.4
152	$T_3S_3V_1E_3R_2$	1273.2
153	$T_3S_3V_1E_3R_3$	1275.3
Mean		1274.3

154	$T_3S_3V_2E_1R_1$	884.1
155	$T_3S_3V_2E_1R_2$	883.3
156	$T_3S_3V_2E_1R_3$	882.6
Mean		883.3
157	$T_3S_3V_2E_2R_1$	955.4
158	$T_3S_3V_2E_2R_2$	954.8
159	$T_3S_3V_2E_2R_3$	956.6
Mean		955.6
160	$T_3S_3V_2E_3R_1$	1067.8
161	$T_3S_3V_2E_3R_2$	1066.7
162	$T_3S_3V_2E_3R_3$	1068.4
Mean		1067.6

### APPENDIX XVI

**Analysis of variance of variation in application rate w.r.to type of manure,  
operational speed, valve size opening and engine rpm**

Source	Sum of Squares	df	Mean Square	F-value	p-value	
<b>Model</b>	8.99E+06	25	3.60E+05	3633.24	< 0.0001	significant
A-Type of manure	2.16E+06	2	1.08E+06	10893.13	< 0.0001	
B-operational speed	2.01E+06	2	1.01E+06	10178.3	< 0.0001	
C-valve size opening	3.12E+06	1	3.12E+06	31477.35	< 0.0001	
D-engine rpm	1.57E+06	2	7.83E+05	7916.27	< 0.0001	
AB	20832.36	4	5208.09	52.64	< 0.0001	
AC	3282.72	2	1641.36	16.59	< 0.0001	
AD	56956.87	4	14239.22	143.91	< 0.0001	
BC	30414.82	2	15207.41	153.69	< 0.0001	
BD	14967.88	4	3741.97	37.82	< 0.0001	
CD	9917.18	2	4958.59	50.11	< 0.0001	
<b>Residual</b>	13456.8	136	98.95			
Lack of Fit	13344.68	28	476.6	459.06	< 0.0001	insignificant
Pure Error	112.13	108	1.04			
<b>Cor Total</b>	9.00E+06	161				

<b>Std. Dev.</b>	9.95	<b>R<sup>2</sup></b>	0.9985
<b>Mean</b>	1131.61	<b>Adjusted R<sup>2</sup></b>	0.9982
<b>C.V. %</b>	0.879	<b>Predicted R<sup>2</sup></b>	0.9979
		<b>Adeq Precision</b>	257.3256

## APPENDIX XVII

### Specifications of the tractor used for field evaluation of prototype manure pulverizer cum applicator.

<b>Manufacturer</b>	John Deere
<b>Model</b>	5065-E
<b>Engine</b>	65 hp, 2400 rpm, 3 cylinder, Rotary FIP, Turbo
Air filter	Dry type, fuel element
<b>Transmission</b>	
Clutch	Dual
Gearbox	9 forward + 3 reverse, Collar shift
<b>Hydraulics</b>	
Lifting capacity, kgf	1800 at lower link ends
3-point linkage	Category II, Automated draft and depth control
Steering	Power
Steering column	Tilt up to 25 degree
Power take off	Independent, 6 splines
RPM	540 @ 2376 E-rpm
<b>Wheels and tyres</b>	
Front	6.5 × 20, 8PR
Rear	16.9 × 30, 12PR
Fuel tank capacity	68 Liters
Electrical systems	88 Ah, 12 volt battery, 40 Amp
	2.5 kW starter motor, alternator
<b>Dimensions and weight</b>	
Total weight, kg	2290
Wheel base, mm	2035
Overall length, mm	3540
Overall width, mm	1885
Turning radius, mm	3181
Ground clearance, mm	470

## APPENDIX XVIII

## Estimation of cost of the machine

Sl. No.	Material	Qty, nos	Specification, mm	Length, m	Weight, kg m <sup>-2</sup>	Total weight, kg	Cost, Rs.
<b>I</b>	<b>Main frame</b>						
	MS C-channel	1	75×40×3	6.5	7.14	46.41	2000
	MS iron angle	1	50×50×5	1.4	3.79	5.306	261
	MS plate	4	80 × 8	80	0.4	1.61	90
<b>II</b>	<b>Hitch frame</b>						
	MS Flat	1	50 × 15	3	6.3	9.45	925
	Lower hitch pins	2	-	-	-	-	300
<b>III</b>	<b>Chute</b>						
	GI sheet	1	914 × 1.5	1.83	10.76	19.7	997
	MS sheet	1	580 × 4	0.6	18.21	10.93	590.2
	MS iron flat	1	50 × 5	1.8	1.96	3.53	141.2
<b>IV</b>	<b>Blower</b>						
	MS sheet	1	245 × 2	0.5	3.84	1.92	100
	GI sheet	1	914 × 1.5	0.91	10.75	9.79	550
<b>V</b>	<b>Gearbox</b>						
	MS plate	2	250 × 12	0.3	7.07	14.13	863
	MS plate	2	170 × 12	0.3	4.8	9.61	620
	MS plate	2	170 × 12	0.5	4	8.01	540
	MS shaft	1	40	1.2	9.86	11.84	600
	Helical gear	1	48 teeth	-	-	-	850
	Helical gear	1	36 teeth	-	-	-	685
	Helical gear	1	26 teeth	-	-	-	650
	Bevel gears	2	24 teeth	-	-	-	1,534
	Ball bearings	7	52 × 25	-	-	-	372
	Oil	1	-	-	-	-	1250

	Keys	8	6	30 mm	-	-	50
<b>VI</b>	<b>Power transmission</b>						
	MS shaft	1	32 (dia)	0.72	6.31	4.54	270
	Block bearings	2	1 1/8"	-	-	-	1580
	V-pulley	1	6"	-	-	-	520
	Solid V-pulley	1	5"	-	-	-	685
	V-pulley	1	3 1/2"	-	-	-	620
	V-belt	1	B42	-	-	-	290
	V-belt	2	B40	-	-	-	560
	V-belt	2	B38	-	-	-	550
	Flange coupling	1	100	10 cm	-	-	1450
<b>VII</b>	<b>Others</b>						
	Nut & bolt	25	6 mm (dia)	1"	-	-	50
	Nut & bolt	20	6 mm (dia)	2"	-	-	75
	Nut & bolt	15	10 mm (dia)	2"	-	-	90
	M seal	4	-	-	-	-	120
	Welding rods	-	-	-	-	-	750
	Paint	-	-	-	-	-	400
<b>Total cost</b>							22,000
		<b>Fabrication</b>					15,000
<b>Total cost of applicator</b>							37,000

## APPENDIX XIX

### Cost economics of manure pulverizer cum applicator

#### A. Cost of operation of proto type manure pulverizer cum applicator

##### 1. Tractor

##### *Assumptions*

Initial cost of tractor (C), Rs	:	10,00,000
Useful life (IS 9164:1979), (L), years	:	10
Annual usage (IS 9164:1979), (H), hours	:	1000
Interest rate (i), %	:	10

##### **Fixed cost**

a. Depreciation, Rs h <sup>-1</sup>	=	$\frac{C-S}{L \times H}$
	=	$\frac{10,00,000 - 1,00,000}{10 \times 1000}$
	=	90
b. Interest on capital, Rs h <sup>-1</sup>	=	$\frac{C+S}{2} \times i$
	=	$\frac{10,00,000 + 1,00,000}{2 \times 1000} \times \frac{10}{100}$
	=	55
c. Insurance and taxes (1.5 % of initial cost of tractor), Rs h <sup>-1</sup>	=	$\frac{10,00,000}{1000} \times \frac{1.5}{100}$
	=	15
d. Housing (0.5% of initial cost of tractor), Rs h <sup>-1</sup>	=	$\frac{10,00,000}{1000} \times \frac{0.5}{100}$
	=	5



$$\text{Total fixed cost (a + b + c + d), Rs h}^{-1} = 165$$

### Variable cost

$$\text{a. Average diesel consumption, l h}^{-1} = 3.5$$

$$\text{Fuel cost, Rs h}^{-1} = 3.5 \times 55$$

$$= 192.5$$

$$\text{b. Lubrication (10\% of fuel cost) , Rs h}^{-1} = 192.5 \times 10 \ 100$$

$$= 19.25$$

$$\text{c. Repair and maintenance (5 \% of initial cost of tractor) , Rs h}^{-1}$$

$$= \frac{10,00,000}{1000} \times \frac{5}{100}$$

$$= 50$$

$$\text{d. Operator wages (Rs. 700/day of 8 hours) , Rs h}^{-1} = \frac{700}{8}$$

$$= 87.5$$

$$\text{Total variable cost (a + b + c + d), Rs h}^{-1} = 349.25$$

$$\text{Total operating cost of tractor} = 514.25$$

### 2. Manure pulverizer cum applicator

$$\text{Cost of KAU manure pulverizer, Rs} : 32,500$$

$$\text{Cost of KAU manure pulverizer without motor, Rs} : 32,500 - 5,500$$

$$: 27,000$$

$$\text{Cost of manure applicator alone, Rs} : 22,000$$

$$\text{Labour cost, Rs} : 15,000$$

$$\text{Total cost of manure pulverizer cum applicator, Rs} : 27000 + 22000 + 15000$$

$$: 64,000$$

Initial cost of machine (C), Rs	:	64,000
Useful life (IS 9164:1979), (L), years	:	10
Annual usage (IS 9164:1979), (H), hours	:	200
Interest rate (i), %	:	10

**Fixed cost**

a. Depreciation, Rs h <sup>-1</sup>	=	$\frac{C-S}{L \times H}$
	=	$\frac{64,000-6,400}{10 \times 200}$
	=	28.8
b. Interest on capital, Rs h <sup>-1</sup>	=	$\frac{C+S}{2} \times i$
	=	$\frac{64,000+6,400}{2 \times 200} \times \frac{10}{100}$
	=	17.6
c. Insurance and taxes (1.5 % of initial cost), Rs h <sup>-1</sup>	=	$\frac{64,000}{200} \times \frac{1.5}{100}$
	=	4.80
d. Housing (0.5% of initial cost of tractor), Rs h <sup>-1</sup>	=	$\frac{64,000}{200} \times \frac{0.5}{100}$
	=	1.60
Total fixed cost (a + b + c + d), Rs h <sup>-1</sup>	=	52.8

**Variable cost**

Repair and maintenance (5 % of initial cost of tractor), Rs h <sup>-1</sup>	=	$\frac{64,000}{200} \times \frac{5}{100}$
---	---	---

	=	16
Total variable cost, Rs h <sup>-1</sup>	=	16
Total operating cost of manure applicator	=	68.8
Total operating cost of tractor and manure pulverizer cum applicator, Rs h <sup>-1</sup>	=	583.05
Total operating cost of tractor and manure pulverizer cum applicator, Rs ha <sup>-1</sup>	=	583.05 ÷ 0.3
	=	1,943.5

### **B. Cost of manual manure application**

Cost of KAU manure pulverizer, Rs	:	38,500 (including GST)
Capacity of the machine, kg h <sup>-1</sup>	:	500
Electricity required, kW h <sup>-1</sup>	:	8.2
Initial cost of machine (C), Rs	:	38,500
Useful life (IS 9164:1979), (L), years	:	10
Annual usage (IS 9164:1979), (H), hours	:	100
Interest rate (i), %	:	10

### **Fixed cost**

a. Depreciation, Rs h <sup>-1</sup>	=	$\frac{C-S}{L \times H}$
	=	$\frac{38,500-3,850}{10 \times 100}$
	=	34.65
b. Interest on capital, Rs h <sup>-1</sup>	=	$\frac{C+S}{2} \times i$
	=	$\frac{38,500+3,850}{2 \times 100} \times \frac{10}{100}$

$$= 21.175$$

c. Insurance and taxes (1.5 % of initial cost), Rs h<sup>-1</sup>

$$= \frac{38,500}{100} \times \frac{1.5}{100}$$

$$= 5.775$$

d. Housing (0.5% of initial cost of tractor), Rs h<sup>-1</sup>

$$= \frac{38,500}{100} \times \frac{0.5}{100}$$

$$= 1.925$$

Total fixed cost (a + b + c + d), Rs h<sup>-1</sup>

$$= 63.525$$

**Variable cost**

a. Repair and maintenance (5 % of initial cost of tractor), Rs h<sup>-1</sup>

$$= \frac{38,500}{100} \times \frac{5}{100}$$

$$= 19.25$$

b. Cost of unit electricity

$$= 6.10 \text{ Rs per kWh}$$

Power consumption of the machine

$$= 8.2 \text{ kWh}$$

Total cost of electricity, Rs

$$= 6.10 \times 8.2 = 50$$

Labour cost per person, Rs h<sup>-1</sup>

$$= 150$$

No. of labours

$$= 3$$

Total labour cost

$$= 450$$

Total variable cost, Rs h<sup>-1</sup>

$$= 19.25 + 50 + 450$$

$$= 519.25$$

Total cost of manual manure application, Rs h<sup>-1</sup>

$$= 63.525 + 519.25$$

$$= 582.775$$

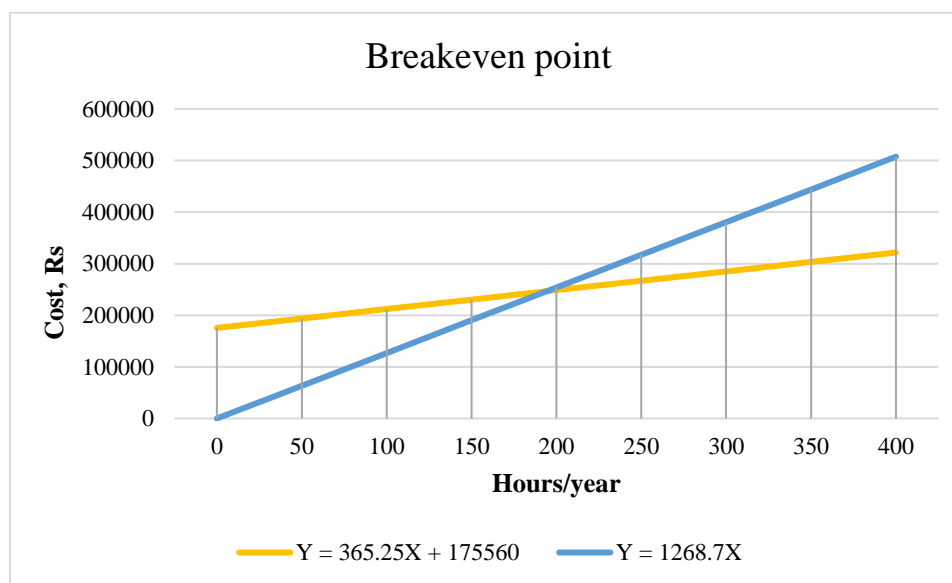
Assuming 8 h are needed for applying 1 ha of land manually for 3 labours.

Total cost of manual manure application, Rs ha<sup>-1</sup> = 4,662.2

### Calculation of Breakeven point and payback period

Total fixed cost per year, Rs = 175,560  
 Total variable cost, Rs h<sup>-1</sup> = 365.25  
 Custom hiring cost, Rs ha<sup>-1</sup> = 728.78  
 Custom hiring cost, Rs h<sup>-1</sup> = 1,268.7  
 Total operating cost, Rs h<sup>-1</sup> = 583.05  
 Total operating cost, Rs ha<sup>-1</sup> = 1,943.5  
 Total area covered per year, ha = 60  
 Breakeven point, h yr<sup>-1</sup> = 185

#### a. Breakeven point



#### b. Payback period

Initial cost of machine, Rs = 64,000  
 Custom hiring charge, Rs h<sup>-1</sup> = (25 % over cost of operation, Rs h<sup>-1</sup>)  
 = (583.03 × 1.25)  
 = 728.78  
 Average net annual benefit, Rs = (CHC - TOC) × Annual utility

$$\begin{aligned} &= (728.78 - 583.03) \times 185 \\ &= 26,963.75 \\ \text{Payback period} &= \frac{\text{Initial investment}}{\text{Average net annual benefit}} \\ &= \frac{64000}{26963.75} \\ &= 2.37 \end{aligned}$$

# ABSTRACT

**DEVELOPMENT AND PERFORMANCE EVALUATION OF A TRACTOR  
POWERED MANURE PULVERIZER CUM APPLICATOR**

**By**

**S. SAI MOHAN**

**(2018-18-016)**

**ABSTRACT OF THE THESIS**

**Submitted in partial fulfilment of the requirement for the degree of**

**MASTER OF TECHNOLOGY**

**IN**

**AGRICULTURAL ENGINEERING**

**(Farm Power and Machinery)**

**Faculty of Agricultural Engineering and Technology**

**Kerala Agricultural University**



**DEPARTMENT OF FARM MACHINERY AND POWER ENGINEERING**

**KELAPPAJI COLLEGE OF AGRICULTURAL ENGINEERING AND  
TECHNOLOGY**

**TAVANUR – 679 573**

**KERALA, INDIA**

**2020**



## ABSTRACT

Organic manures such as farm yard manure, green manure etc., when incorporated into the soil not only add nutrients but enriches the soil by the fixation of atmospheric nitrogen. Manures (FYM, vermicompost, edible oil cakes etc.) are an important resources which provide nutrients that could reduce bagged fertilizer costs and improves the crop growth and performance. A well-managed manure is a valuable resource in providing nutrients for crop production. Use of farm yard manure and other organic manure is the way out to overcome the problems of soil degradation, loss of fertility and soil health. Manual application of manure consumes more time and labour. Therefore, the present study was undertaken to develop and evaluate the performance of a tractor powered manure pulverizer cum applicator. The components of the machine were developed to suit the various dosages of manure without much variation in the distribution efficiency.

The actual field capacity and efficiency of manure pulverizer cum applicator was found out to be 0.311 ha h<sup>-1</sup> and 86.5 % at a forward speed of 2.0 km h<sup>-1</sup>, 0.356 ha h<sup>-1</sup> and 79.2 % at a forward speed of 2.5 km h<sup>-1</sup> and 0.395 ha h<sup>-1</sup> and 73.1 % at a forward speed of 3.0 km h<sup>-1</sup>. Maximum field capacity was noted at a traveling speed of 3.0 km h<sup>-1</sup>. A larger application rate of 1387.1 kg ha<sup>-1</sup> for cow dung, 1624.4 kg ha<sup>-1</sup> for goat faecal pellets and 1618.6 kg ha<sup>-1</sup> for neem cake was noted at an engine rpm of 2500, forward speed of 2 km h<sup>-1</sup> with a field capacity of 0.31 ha h<sup>-1</sup>. With increasing the forward speed to 2.5 and 3.0 km h<sup>-1</sup>, field capacity increases but the application rate is decreased.

The cost of manure pulverizer cum applicator alone is Rs. 64,000. Cost of operation of manure pulverizer cum applicator as an attachment to tractor as explained in Section 3.4 was found as 583.05 Rs h<sup>-1</sup> and 1943.5 Rs ha<sup>-1</sup>. Cost of manual manure application followed by manure pulverization was 582.7 Rs h<sup>-1</sup> and 4662.2 Rs ha<sup>-1</sup>.